



EMPOWERED PERFORMANCE

# SUSTAINABILITY REPORT

OMAL 2019



[www.omal.com](http://www.omal.com)





EMPOWERED PERFORMANCE

# SUSTAINABILITY REPORT

OMAL 2019



[www.omal.com](http://www.omal.com)

# LET'S DO A GOOD JOB

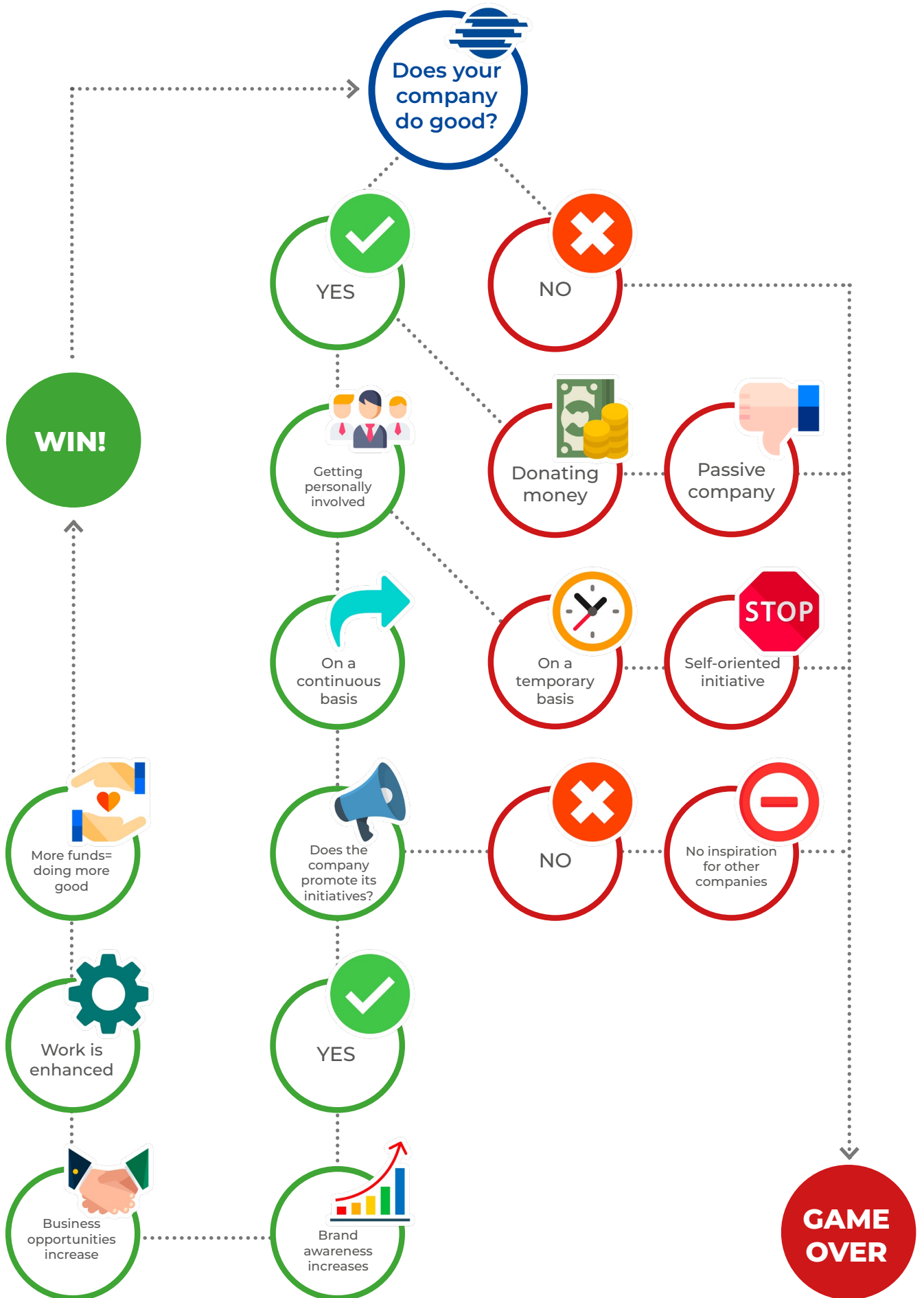

## 1. IDENTITY

7

1.1 Letter from the CEO.....	9
1.2 About us.....	10
1.3 History.....	11
1.4 Vision, Mission, Values.....	12
1.5 Transparency and legality rating.....	13
1.6 Governance, business model and strategy.....	14
1.7 Being B Corp.....	16



## 2. CORPORATE SOCIAL RESPONSIBILITY

19

2.1 Corporate social responsibility for OMAL.....	21
2.2 Methodological note.....	22
2.3 2016-2020 strategic plan.....	23
2.4 International context.....	24
2.5 Materiality matrix.....	26
2.6 Stakeholders and engagement.....	29



## 3. PEOPLE AND COMMUNITY

35

3.1 A precious resource.....	37
3.2 Ethics at OMAL.....	41
3.3 Engagement.....	41
3.4 Training.....	42
3.5 Health and safety.....	44
3.6 Welfare.....	45
3.7 Community.....	46
3.8 Philanthropy.....	47



## 4. QUALITY

51

4.1 The value of quality.....	53
4.2 The importance of design.....	58
4.3 Our product.....	60
4.4 Certifications.....	63
4.5 Production process.....	66
4.6 Quality suppliers and raw materials.....	72
4.7 Sustainable supply chain.....	78
4.8 Customer satisfaction.....	80



## 5. ENVIRONMENT

85

5.1 Respect for the environment.....	87
5.2 Awards for our commitment to the environment.....	88
5.3 Management system and environmental policy.....	89
5.4 Green In.....	91
5.5 Green Us.....	93
5.6 Sustainability of OMAL products.....	108
5.7 Future prospects.....	112



## 6. ECONOMIC VALUE AND REPUTATION

115

6.1 Economic results.....	117
6.2 Investments.....	119
6.3 Ratings and awards.....	120
6.4 Market presence and commercial development.....	122
6.5 Sales conferences and fairs.....	124
6.6 Intangible assets and reputation.....	129
6.7 Communication and media presence.....	130
6.8 Future prospects.....	145



## ANNEXES

147

● GRI Table.....	148
● Glossary.....	154



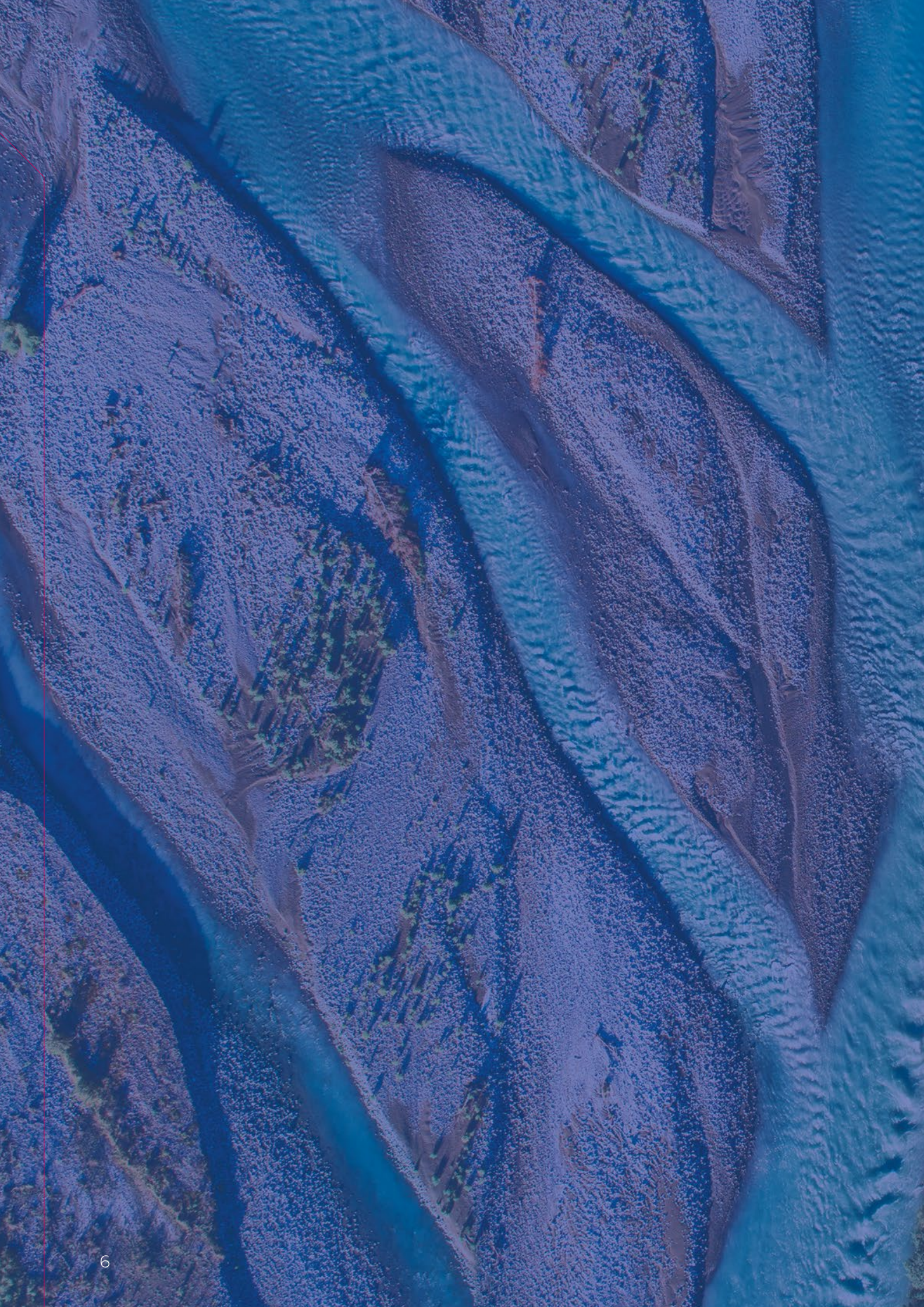



IDENTITY

1

1. IDENTITY

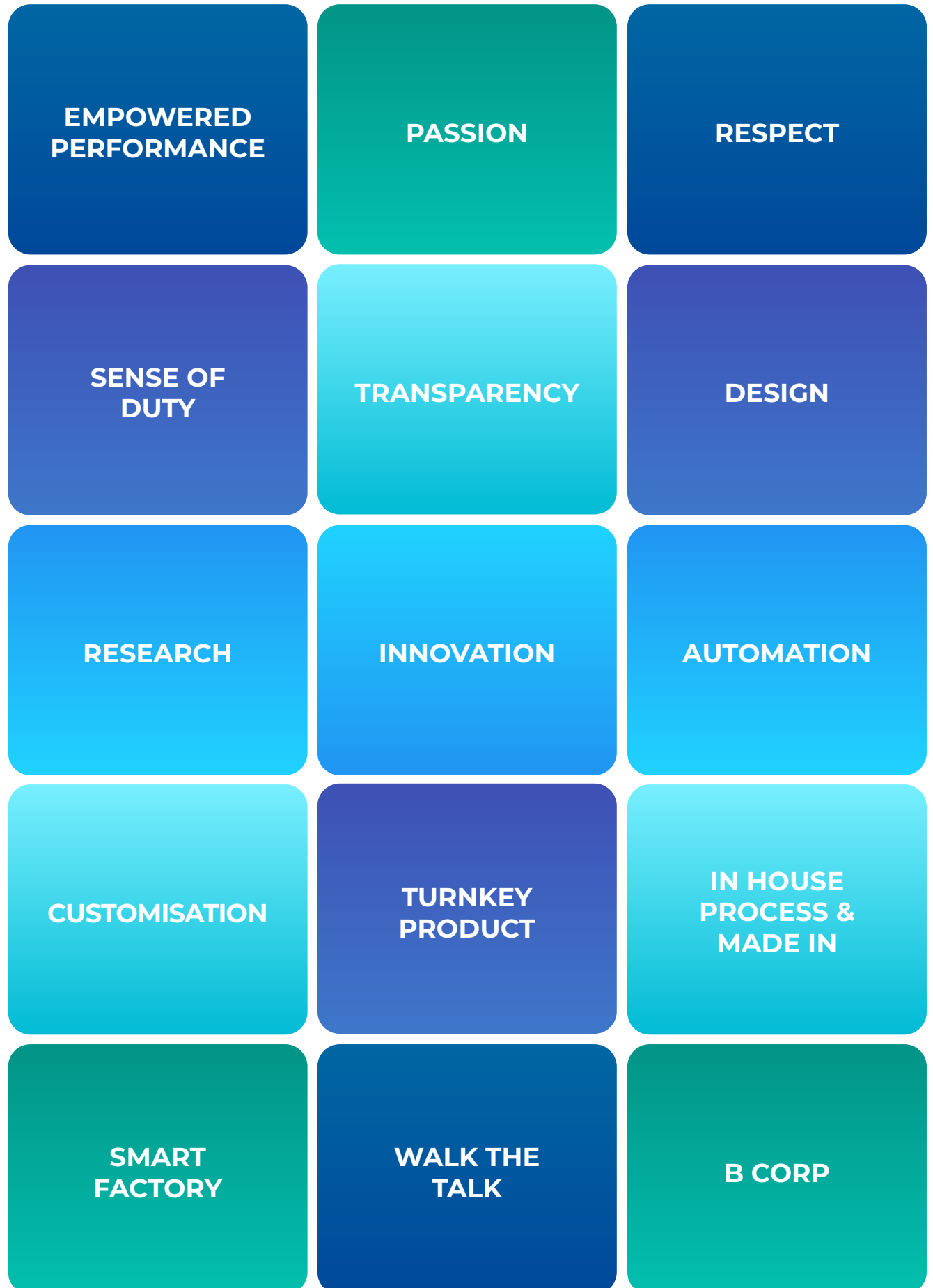



# 1.1 LETTER FROM THE CEO

**W**e, like other companies, take on important responsibilities not only towards customers, investors, suppliers, but also towards employees, society and the world itself.

We are aware that we have a responsibility to produce sustainably and to be at the forefront of addressing the urgent challenges of progress. For instance, climate change is becoming a determining factor in companies' long-term prospects; many have stressed the significant and lasting impact it will have on economic growth and prosperity, and the resulting risks that today can no longer be ignored, even by the market.

We are committed

- to the **products** and services we create;
- to the **means** and **resources** we use;
- through the **Values** we represent;
- with **awareness** of the impact of our actions on the world;

to ensure:

- the use of technology as a means to improve life;
- the **safeguarding** and protection of the environment;
- **respect** for the law, for people and for human dignity;

## 1 Improving life through innovation

Technological development is changing the world; it will revolutionise workplaces, places and lifestyles. We want to contribute to building a healthy and sustainable society that offers everyone the same opportunities without prejudice to future generations. For us, this means improving the performance and energy consumption of our products to help shape a more sustainable energy future in line with community expectations.

## 2 Safeguarding and protection of the environment

We are committed to reducing the carbon footprint (CO<sub>2</sub> emissions) of our organisation and supply chain, sharing these benefits with stakeholders by providing "Empowered performances".

## 3 Respect for laws and people

Our **Values**, the Code of Ethics and the Supplier Code of Conduct characterise our approach to business: respect for the law, for people, a sense of duty, passion, honesty, transparency, data security and responsibility.

We want to run a safe, responsible and profitable business, offering everyone equal prospects, job and career opportunities and recognising merit and skills. We have brought new people into the organisation to enrich it with the talent and skills we will need to support our growth.

We build our goals and measure our performance in accordance with the principles of the Global Compact and the 17 United Nations Sustainable Development Goals.

We are **Passionately** committed to ensuring that our business creates value for our stakeholders, promoting the growth of our employees and creating a positive impact on the community.

**Amedeo Bonomi**  
CEO OMAL S.p.A.



## 1.2 ABOUT US

**W**e have been producing valves and actuators since 1981. We put our **expertise** and **professionalism** into providing a **customised** product for our customers, which guarantees the **highest quality** and **performance**, designed for various sectors such as food, chemical and pharmaceutical, power and energy, naval and many others.

Our motto is *Empowered Performance*. Because only an *empowered* process can guarantee a product with *empowered performance*.

*Empowered performance* is achieved by **internalising** all processes, ensuring **Made in Italy quality** and ensuring full **control along the entire value chain**. We are thorough when **selecting our suppliers**, basing our selection on not only economic parameters, but also sustainability, quality and innovation. We invest in **technological development** to ensure precision and speed.

For OMAL, *empowered performance* also means producing with great care for the environment and the surrounding area, as well as people and corporate social responsibility.

Our product is *empowered* because it is designed to guarantee maximum performance throughout its life cycle: from design, to construction, up to commissioning and operation, ensuring durability and low consumption.



EMPOWERED PERFORMANCE

# 1.3 HISTORY

OMAL was founded in Polaveno in Val Trompia in 1981 at the behest of Agostino Bonomi, son of a dynasty of entrepreneurs specialising in ball valves, who understood that the future of this sector should focus on automation and the customisation of products for industrial use.

Thanks to the creation of a team of specialised technicians and engineers, in just a few years OMAL established itself on the domestic and foreign markets with an innovative product able to effectively meet the most complex technical needs, with high performance, suitable for various applications and customised for its customers' specific needs.

Design, research, innovation, automation and customisation are the keys to OMAL's success. The stages of this success:

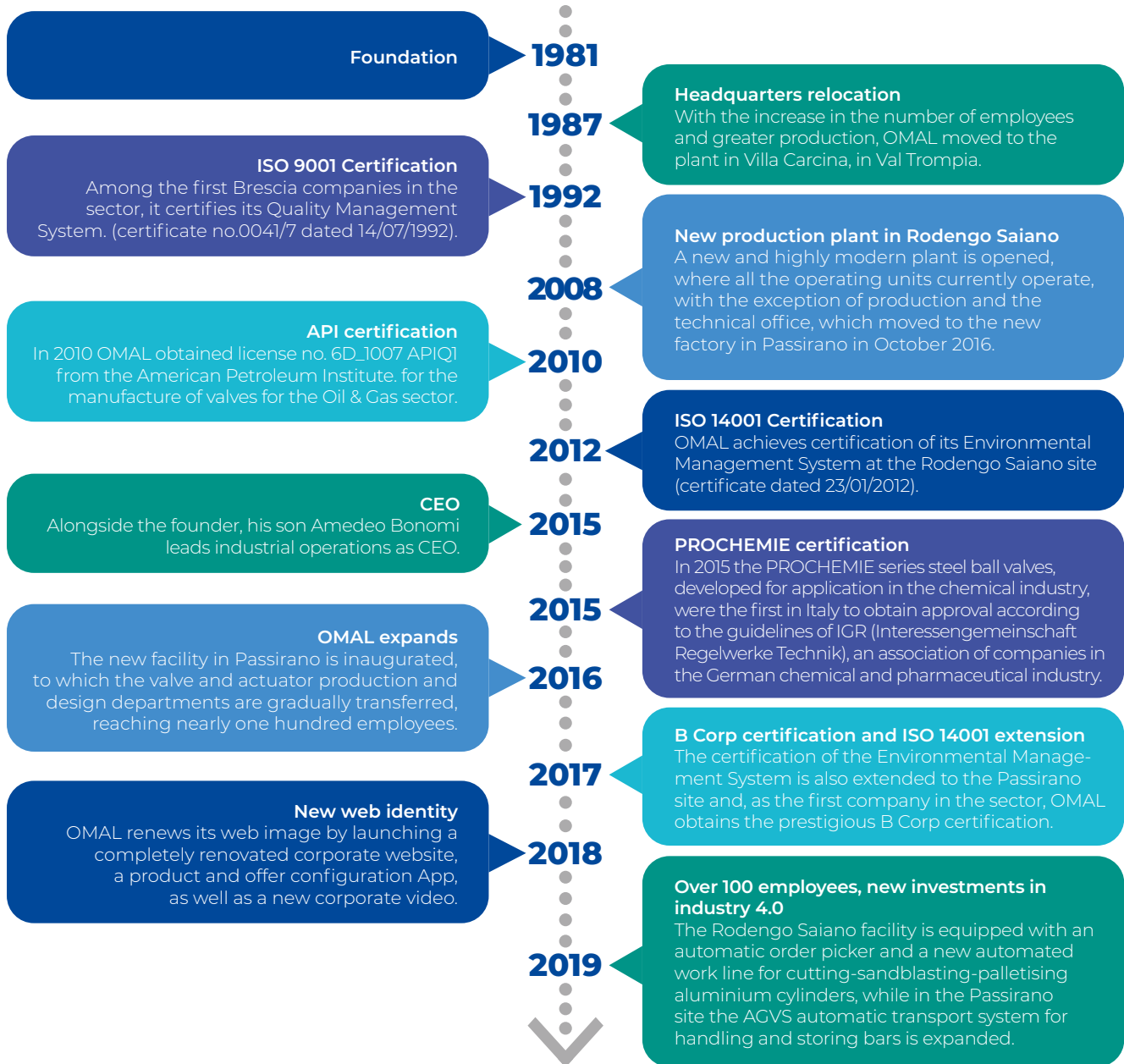



All of OMAL's production activity still takes place in Italy, over a total area of 38 thousand square meters of which 17 thousand are covered.

We firmly believe that the added value of OMAL's achievements is represented by the all-Italian ability to design and manufacture a mechanical product with special attention and dedication, with craftsmanship that takes great care of every detail in order to meet all of our customers' needs.

# 1.4 VISION, MISSION, VALUES

**W**e believe in the strength of our reputation. We believe that a company's true value is the reputation it has been able to build over the years thanks to its daily work, the relationships it has created and the ability to meet its stakeholders' expectations.

 <p><b>VISION</b></p> <p>We believe that the right balance between man and the environment improves the quality of life, guaranteeing a better world for future generations.</p>	 <p><b>MISSION</b></p> <p>We work to create products with ever higher performance, able to protect the environment and improve the quality of life by making systems safer and more reliable.</p>	 <p><b>VALUES</b></p> <p>We believe that actions are the best way to tell the story of a company like OMAL, which does not back down and substantiates its words with concrete actions.</p>
---	--	--

OMAL's identity is based on three guiding principles that represent our uniqueness: passion, respect and a sense of duty.

<p><b>PASSION</b></p> <p>For OMAL, Passion means settling for average results, but continuously trying to exceed our performance, always striving to improve our products and processes. All this without ever forgetting the human dimension, encouraging personal growth, guaranteeing a stimulating work environment that is open to dialogue.</p> <p><i>"You know you're in a magical place when you come home and you can't stop thinking about that piece you can't design, or that process testing your patience... and you realise you haven't brought your job home, but passion".</i></p>	<p><b>RESPECT</b></p> <p>For OMAL, Respect means the ability to recognise the needs and differences of its stakeholders, whether colleagues or business partners, respecting everyone's position and continuously exchanging ideas in order to identify shared and effective solutions.</p> <p><i>"We don't need internal rules to understand that in everything we do we must respect our role and the dignity of our work, every day, towards everyone"</i></p>	<p><b>SENSE OF DUTY</b></p> <p>For OMAL, a Sense of Duty means respecting agreements, promises and ambitions, maintaining the established time frames and methods shared with our partners. Where necessary, the Sense of Duty requires the flexibility to find brave, original and outside-the-box solutions.</p> <p><i>"We don't need many words to explain what a sense of duty means to us, three are enough: never give up".</i></p>
---	---	---



The values OMAL believes in make up the **OMAL Code of Ethics**, a crucial strategic document for the company's positioning within the world of CSR and sustainable business. The Code of Ethics, divided into various sections according to the relevant stakeholder, contains a compendium of the corporate values that each actor interacting with the company is required to respect. The starting point for any CSR rationale is the Code of Ethics, which OMAL distributes to all new employees as a starting point for every fruitful working and human relationship.

## 1.5 TRANSPARENCY AND LEGALITY RATING

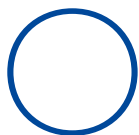

OMAL has voluntarily committed itself to a certification process promoted by AGCM - the competition and market authority - to ensure maximum **transparency** on its **commercial operations** to all stakeholders.

The Legality Rating is an ethical evaluation issued by AGCM in agreement with the Ministries of Justice and the Interior, to Italian companies that have achieved a minimum turnover of two million euros and that demonstrate that they:

- respect the contents of the Legality Protocol signed by the Ministry of the Interior and Confindustria (Italian industrial federation), the guidelines that constitute its implementation, the Protocol signed by the Ministry of the Interior and the League of Cooperatives, and at a local level by the Prefectures and trade associations;
- use payment traceability systems even for amounts lower than those established by law;
- adopt an organisational structure that carries out checks on the compliance of company activities with regulatory provisions applicable to the company or an organisational model pursuant to Legislative Decree no. 231/2001;
- adopt processes to guarantee forms of Corporate Social Responsibility;
- are included in one of the lists of suppliers, service providers and contractors not subject to mafia infiltration attempts;
- have adhered to self-regulatory codes of ethics adopted by trade associations;
- have adopted organisational models to prevent and combat corruption.



In the rating update, which took place in June 2019, OMAL improved its reliability by obtaining a + on top of the two stars previously obtained.

<https://www.agcm.it/competenze/rating-di-legalita/rating-elenco-imprese>

# 1.6 GOVERNANCE, BUSINESS MODEL AND STRATEGY

 MAL's administration and control system is of the "traditional" type with a Board of Directors appointed by the Shareholders' Meeting and a Board of Statutory Auditors.

The BoD is the body vested with powers for the management and definition of organisational structures, as well as for the evaluation of the general performance. It is made up of two directors (Head of the Board of Directors and Director).

The Board of Statutory Auditors is made up of five members and monitors compliance with the law and compliance with the principles of correctness.

An audit firm guarantees the correctness and truthfulness of financial and asset information and ensures regulatory compliance.

The CEO has delegated powers of ordinary and extraordinary administration with regard to safety and hygiene at work, as well as the protection of the environment inside and outside the company (with the exclusion of those reserved by law or by the Articles of Association to the BoD or the Shareholders' Meeting).



There are four governance drivers that characterise OMAL's corporate strategy, making it unique and diversified compared to the competition:

**Turnkey product: valve and actuator**

The experience and know-how accumulated in 40 years of package design and production: valve and actuator allows OMAL to develop and manage product co-engineering collaborations in the pneumatics sector, the industrial world and the process industry.

**In House process & Made In**

OMAL was founded with a strong manufacturing vocation rooted in the Brescia area, particularly specialised in mechanical and industrial processing. OMAL's expertise in mechanical processing and in aluminum die casting is of the highest level. OMAL has also specialised in the plastic moulding of some strategic components thanks to the installation of some production lines with robotic presses. The testing phase is also 100% in house with a test room and test benches dedicated entirely to internal production.

**Smart Factory**

OMAL initially started the digitisation process of the company on the production and assembly lines with intelligent robotisation to guarantee quality and process precision, then in the operational and administrative offices with the use of business intelligence and project management software. OMAL is a smart factory: this is demonstrated by its multi-channel system, the product configurator, an e-commerce site, and the APP available on Android and IOS.

**WalkTheTalk**

The company has a code of ethics that guides it, OMAL presents itself to the market "doing what it says it does". When OMAL makes statements, makes a commitment or simply expresses itself, what it says is a promise that must be fulfilled and must stand for an absolute truth. A truth that does not yield in the face of any flattery from the market.

## 1.7 BEING B CORP

**B** Corp is a company that incorporates positive social and environmental impact objectives into its business strategy, in tune with its economic-financial objectives.

It is a company that is not satisfied with limiting the negative impacts of its work, but uses the strength of its business to regenerate the ecosystem and the surrounding environment, creating shared value.

The B Corp® certification applies to the entire company, and includes all product or service lines and all business areas. A third-party audit certifies the achievement of the required social and environmental sustainability performance.

OMAL obtained the prestigious B Corp® certification in September 2017, far exceeding the required 80 points and demonstrating its high performance with a final evaluation of 106.7 points.

In both 2018 and 2019, it also won the prestigious Best for Environment award presented to the best performing B Corp companies worldwide in the impact category.









AAA  
AUTO



CORPORATE SOCIAL  
RESPONSIBILITY

2



# 2.1 CORPORATE SOCIAL RESPONSIBILITY FOR OMAL

For OMAL Corporate Social Responsibility is the voluntary choice of wanting to integrate social and environmental aspects in our daily production of valves and actuators.

We believe that the overall performance of a company and the effectiveness of its actions are closely related to the wellbeing of the social context in which it operates and the impact generated on the environment. For these reasons, at OMAL, Corporate Social Responsibility is fully integrated into business and Governance, aimed at defining the strategy to best meet the challenges of the market and achieve our growth objectives, as well as to create shared value in the long term.

Sustainability has always accompanied our corporate history, guiding our way of doing business and creating value for stakeholders.

Our aspiration is to progressively integrate sustainability into the day-to-day operations of all company units, in order to achieve consistent operations, in line with the most virtuous and advanced companies in the field of Corporate Social Responsibility.

OMAL is now in its fourth year of reporting on its social and environmental sustainability, based on a practice that is now in-house and communicated to the outside world in a timely and participatory manner. Our awareness stems from a careful approach to corporate values, constantly updated and shared internally, in order to align the Sustainability Report, Code of Ethics, Supplier Code of Conduct and Internal Policies.



## 2.2 METHODOLOGICAL NOTE

The purpose of this Report is to communicate OMAL's response to the social and environmental challenges we are facing to stakeholders and to present our approach to creating shared value.

This Report has been prepared according to the most widespread international guidelines, issued by the Global Reporting Initiative, the **GRI Sustainable Reporting Standards, "core"** option.

A summary table of correlation between the information reported in this Report and the GRI standard indicators is provided in the final annexes.

The reporting period runs from January 2019 to December 2019 and covers all of OMAL's activities and impacts in its production plants in Rodengo Saiano and Passirano.

The data collection process has been coordinated internally at OMAL by the Head of Quality and has indirectly involved all the production units.

Reporting is divided into six sections that define all dimensions of OMAL's activities, starting from its corporate identity (IDENTITY) through its values, business model and sustainability governance, as well as the reporting methodology implemented (CORPORATE SOCIAL RESPONSIBILITY).

Here are the three areas in which OMAL's sustainability is expressed: PEOPLE, QUALITY and ENVIRONMENT.

The last chapter of the reporting (ECONOMIC VALUE AND REPUTATION) is dedicated to economic results, investments made and commercial development, as well as OMAL's intangible assets, communication and reputation.

This document will be disseminated both by means of distribution within the company and with the main customers and suppliers, as well as through the usual publication on our website [www.omal.com](http://www.omal.com)

Each section will open with a summary page that summarises the approach to the subject, the material topics for OMAL in that area, the numbers that depict the size of the company and the reference to the goals of Agenda 2030.

Finally, the final annexes contain tables of correspondence with the indicators provided for by the GRI and the SDGs.



## 2.3 2016-2020 STRATEGIC PLAN

The table below shows a summary of the objectives that OMAL set itself in 2016 in the five-year strategic plan. During 2019, an important turning point was reached towards the completion of most of the goals.

PRIORITY	COMMITMENT	% ACHIEVEMENT AT THE END OF 2019	RESULT
<b>PERFORMANCE DEVELOPMENT DEVELOP VALUE ADDED OPPORTUNITIES</b>			
2	Solution Provider	100%	●
2	TurnkeyProduct	100%	●
3	Product coengineering	70%	●
<b>CORPORATE IMPROVE BRAND REPUTATION</b>			
1	In house process & Made In	100%	●
1	WalkTheTalk	100%	●
3	Product certification with challenging performance	70%	●
3	Prestigious environmental and social certifications	50%	●
1	Economic soundness	100%	●
<b>SMART FACTORY FULL COMPANY DIGITISATION</b>			
2	Smart robotization	90%	●
2	Business intelligence	70%	●
3	Omnichannel development	90%	●
2	Zero Paper project	70%	●
<b>COMPANY ENGAGEMENT Increase collaborators' sense of belonging through the following actions:</b>			
1	"Tutti Convocati" - Meetings with Top Management	100%	●
1	Corporate events	100%	●

**LEGEND:**

- Completed
- To be completed in 2020

## 2.4 THE INTERNATIONAL CONTEXT

The SDGs - Sustainable Development Goals - are the 17 goals for Sustainable Development that the UN is committed to achieving in the 2030 Agenda.

OMAL has included the following international objectives as priorities in its sustainability programmes:

OBJECTIVE	DESCRIPTION	OMAL'S ACTIONS
 <p><b>2</b> ZERO HUNGER</p>	<p>END HUNGER, ACHIEVE FOOD SECURITY AND IMPROVED NUTRITION AND PROMOTE SUSTAINABLE AGRICULTURE.</p>	<p>We believe that eating healthily and safely is a right to be guaranteed to our workers. For this reason we have chosen a new partner certified in the environmental, energy, sustainability and legality fields for a quality service. The menu offered is balanced, with vegetarian dishes, eco-sustainable and local ingredients, 100% recyclable trays, and is in line with OMAL's sustainability objectives.</p>
 <p><b>3</b> GOOD HEALTH AND WELL-BEING</p>	<p>ENSURE HEALTHY LIVES AND PROMOTE WELL-BEING FOR ALL AT ALL AGES.</p>	<p>We promote a healthy and harmonious working environment to provide the best conditions and guarantee physical, psychological and social well-being. Health and safety are the central theme of 2019: awareness and training activities, the show "the virus that saves your life", the purchase of defibrillators, a healthy and balanced canteen and the promotion of corporate welfare.</p>
 <p><b>4</b> QUALITY EDUCATION</p>	<p>ENSURE INCLUSIVE AND EQUITABLE QUALITY EDUCATION AND PROMOTE LIFELONG OPPORTUNITIES FOR ALL.</p>	<p>Culture represents a fundamental value for OMAL. We invest in training people, knowledge dissemination and education. We have launched collaborative projects, research internships with universities, welcomed young people alternating between school and work, and participated in themed seminars to spread the culture of sustainability.</p>





ENSURE AVAILABILITY AND SUSTAINABLE MANAGEMENT OF WATER AND SANITATION FOR ALL.

Improving the quality of the water used, controlling the release of chemicals, limiting the percentage of untreated waste water, and increasing the recycling and reuse of water safely is a concrete commitment at OMAL. The sewage treatment plant and the condensate recovery and filtration system guarantee this commitment.



ENSURE ACCESS TO AFFORDABLE, RELIABLE, SUSTAINABLE AND MODERN ENERGY FOR ALL.

Safeguarding the planet's resources has always been a central theme at OMAL. Energy efficiency, self-production of energy from solar power and the signing of 100% renewable energy supply contracts are objectives that have been achieved for years.



PROMOTE SUSTAINED, INCLUSIVE AND SUSTAINABLE ECONOMIC GROWTH, FULL AND PRODUCTIVE EMPLOYMENT AND DECENT WORK FOR ALL.

We create the conditions to work and live better, we promote a working environment that supports human and professional growth. Continuous research, passion, expertise and *empowered performance* are the strengths of our success. The high levels of productivity have allowed us to increase employment to over 100 employees.

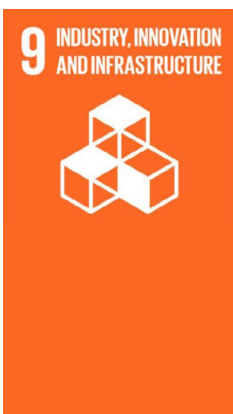

BUILD RESILIENT INFRASTRUCTURE, PROMOTE INCLUSIVE AND SUSTAINABLE INDUSTRIALIZATION AND FOSTER INNOVATION.

The brand new facility in Passano is built according to the best architectural and environmental standards. The adoption of advanced industry 4.0 processes guarantees process automation; a project management system ensures coordinated activity management; the digitisation of documentation facilitates access, exchange and correct archiving of information.

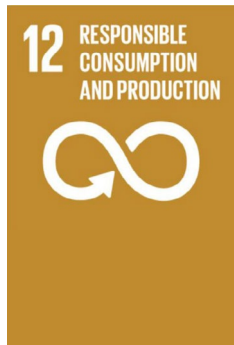

ENSURE SUSTAINABLE CONSUMPTION AND PRODUCTION PATTERNS.

OMAL shares its ethical and sustainability principles (supplier code of conduct) with its suppliers to ensure a responsible and efficient supply chain. Our products are designed to guarantee empowered performance: durability, lower energy consumption, minimum maintenance, disassembly at end of life and recyclability of materials.



TAKE URGENT ACTION TO COMBAT CLIMATE CHANGE AND ITS IMPACTS.

Minimising its environmental impacts is a challenge that OMAL has set in motion since 2016, with the choice of how to measure, monitor and optimise the effects of its activities on the environment and compensate where possible.

## 2.5 MATERIALITY MATRIX

The concept of materiality is central to the GRI Guidelines and refers to the **identification of the most relevant issues for OMAL and its stakeholders**.

This analysis activity, started in 2016 and updated annually, has allowed us to define a **materiality matrix**, i.e. the tool that indicates the relevance given by the company and its stakeholders to specific issues, in order to identify those on which to focus our action, focusing our expectations and timing. The analysis of the relevant issues was also influenced by the opinion of the media, the approach of Italian and foreign competitor companies, the OMAL code of ethics and the presence of global megatrends reported in international documents and policies.

The image below represents the OMAL materiality matrix, updated during 2019 in terms of the company's priorities. The relevance given by the company to the issues emerging from stakeholder engagement is shown horizontally, while the relevance given by the stakeholders involved is shown vertically.



## 2. CORPORATE SOCIAL RESPONSIBILITY

With regard to the aims of the Materiality Matrix, as already mentioned, it represents the working framework of CSR activities in the company and therefore serves to define long-term programmes, which have already been launched by OMAL, such as:

- **INTEGRATING SUSTAINABILITY IN ALL CORPORATE FUNCTIONS**

The desire to integrate elements of Environmental Sustainability into the Purchasing, Communication / Social Innovation, Commercial, Administration, Quality, Technical, IT, Assembly and Production operations, with lean impacts in the management of internal processes.

- **CO-CREATION**

Sharing initiatives with different players both within OMAL, and between OMAL and external players.

- **REPEATABILITY**

Scalability of experiences in other regions, with other players and/or with longer timescales and consequently wider impacts.

- **RELEVANCE**

Evidence of greater interest.



## 2.6 STAKEHOLDERS AND ENGAGEMENT

Stakeholders are people, groups or entities that interact at various levels with OMAL. A dense network of commercial, economic and institutional relations that make up our world and form the basis of continuous exchanges and benefits. Their mapping was conducted on the basis of the principles of:

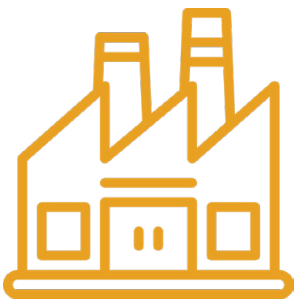

### Dependency

Referred to the extent to which stakeholders are more or less close to the company's economic activities.



### Responsibility

Referred to legal, social, commercial or environmental responsibility ties that bind the stakeholder to the company.



### Necessity

Referred to the need to consider a given stakeholder because they are important.

Once the stakeholders were identified, the main channels of exchange and information with the company were then analysed.

# OMAL STAKEHOLDERS AND THE MAIN EXCHANGE AND INFORMATION CHANNELS

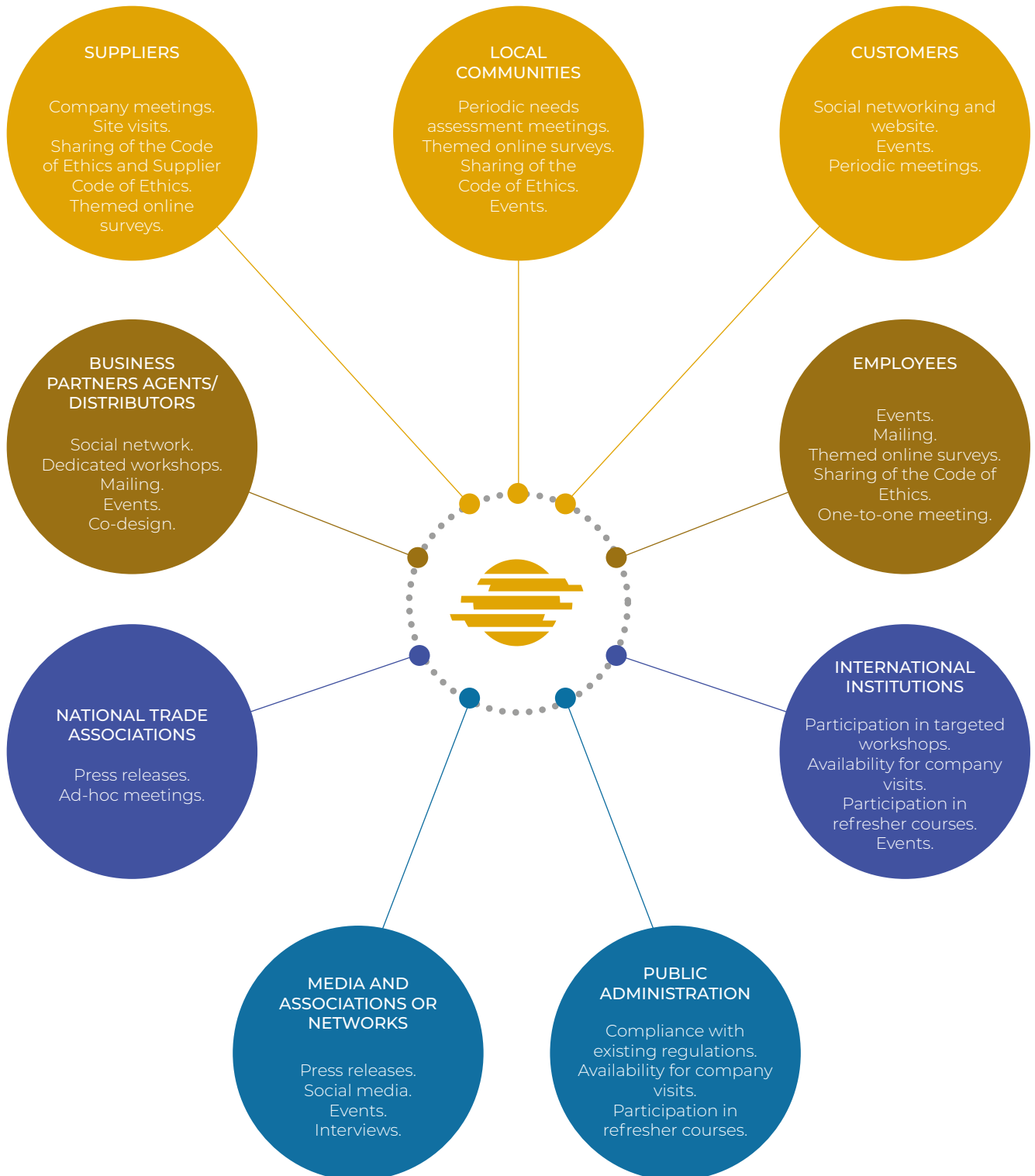

The **stakeholder engagement** process is a process by which an organisation involves all those who can influence the achievement of the company's objectives, or who can be influenced by the achievement of its objectives, in the formulation of its corporate policies or strategies.

Starting from 2016, OMAL has used various channels of stakeholder engagement, in order to obtain opinions and ideas for improvement.

In particular:

WEB SITE

NEWSLETTER

SOCIAL NETWORK

MEDIA

POLICY PAPER

PARTICIPATION IN EVENTS AND CONFERENCES

SUSTAINABILITY REPORT

AD-HOC MEETINGS WITH STAKEHOLDERS FOR SHARED PROJECTS

# LEVELS OF ENGAGEMENT

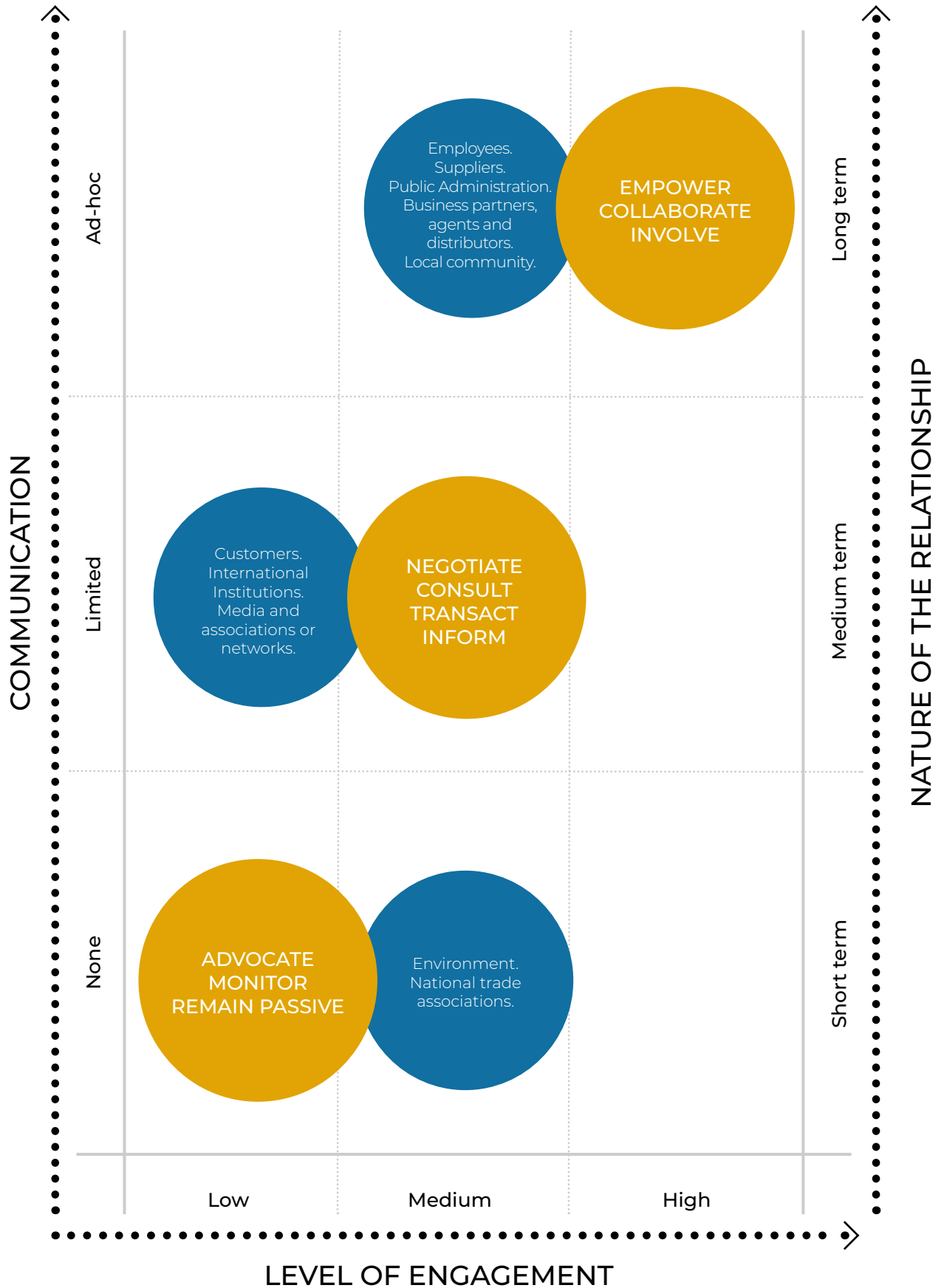









PEOPLE AND  
COMMUNITY

3

# PEOPLE: A PRECIOUS RESOURCE

## Material issues

Training and development of resources	Health and Safety	Protection / creation of work, welfare, quality of life	Philanthropy and community
---------------------------------------	-------------------	---	----------------------------

People are a precious resource and OMAL is committed to guaranteeing a safe, respectful and stimulating work environment. Sharing OMAL's values and code of ethics is a duty to always guarantee empowered performance.

<p>NUMBER OF EMPLOYEES</p> <p><b>103</b></p>	<p>PERMANENT CONTRACTS</p> <p><b>93,2%</b></p>	<p>OCCUPATIONAL HEALTH AND SAFETY INDEX</p> <p><b>100%</b></p>
<p>PEOPLE UNDER 35 YEARS</p> <p><b>45,6%</b></p>	<p>WHITE COLLAR WORKERS</p> <p><b>50%</b></p>	<p>HOURS OF TRAINING</p> <p><b>+32,5%</b></p>

## Reference Goal - GRI (Global Reporting Initiative)

<p><b>3</b> GOOD HEALTH AND WELL-BEING</p> 	<p><b>4</b> QUALITY EDUCATION</p> 	<p><b>8</b> DECENT WORK AND ECONOMIC GROWTH</p> 
--	---	---

## 3.1 A PRECIOUS RESOURCE

Since its inception OMAL has invested in the development of human capital and in the creation of a stimulating and creative environment in which to encourage the professional growth of collaborators and their engagement. Always inspired by the belief that entrepreneurial success is based on the sharing of passion, respect and a sense of duty.

We promote a pleasant, comfortable and harmonious work environment to offer the best possible conditions and guarantee physical, psychological and social well-being.



### 3. PEOPLE AND COMMUNITY

In 2019 our workforce increased significantly, by 13.2%, thus exceeding 100 employees.

#### NUMBER OF EMPLOYEES PER YEAR

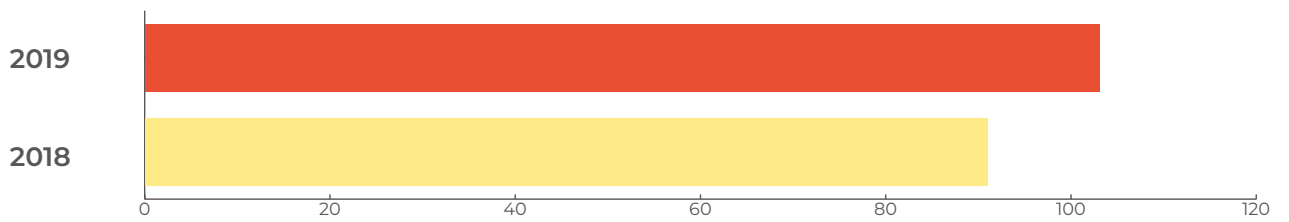

Below are the employee data divided by type of contract and gender:

Type of contract	No. workers	% of the total workforce	% men	% women
Temporary workers	7	6,8%	71,4%	28,6%
Permanent workers	96	93,2%	84,4%	15,6%
<b>Total</b>	<b>103</b>	<b>100,0%</b>	<b>83,5%</b>	<b>16,5%</b>

When it appears that OMAL is a male-dominated company, in 93.2% of cases a permanent contract is applied, 71.4% of temporary contracts are male, but the incidence is higher among women.

OMAL  
employees by  
gender

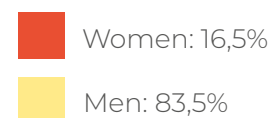
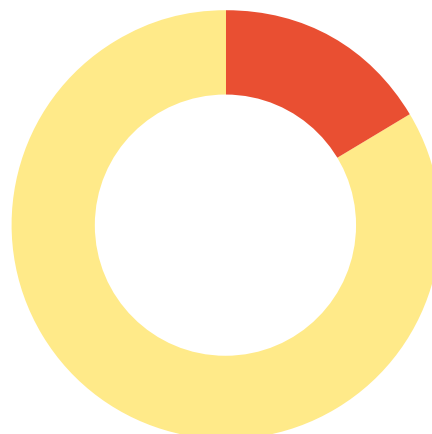

As we can see, this is a young company, almost half of the employees are under 35 years of age and over 90% are under 50, with length of service mainly under 10 years.

OMAL employees by age

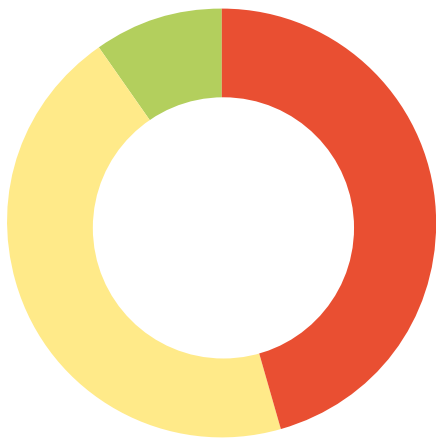

- 35 and under: 45,6%
- 36 to 50 years: 44,7%
- Over 50 years: 9,7%

OMAL employees by length of service

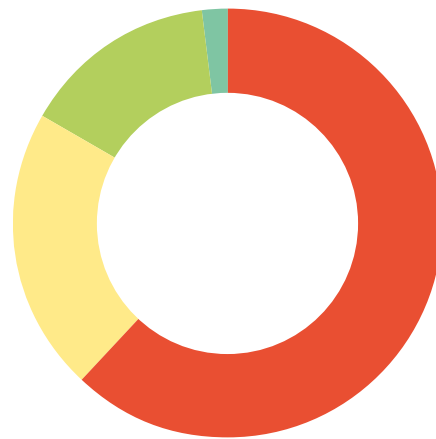

- 10 and under: 62,1%
- 11 to 20 years: 21,4%
- 21 to 30 years: 14,6%
- Over 30 years: 1,9%

As OMAL is constantly expanding, the length of service is low, but about 38% of the staff have been working with us for over 10 years. It can therefore be concluded that the turnover rate is low.

OMAL's distinctive feature of always counting on a team of specialised technicians and engineers is shown by the graph below, demonstrating that design, research and innovation are at the heart of our activities, guaranteed by a high level of specialisation of our staff.

OMAL staff by activity carried out



- Workers: 50%
- Engineers & Technicians: 33%
- Marketing & Accounting: 17%

Our organisational chart:

## OMAL ORGANIZATION CHART

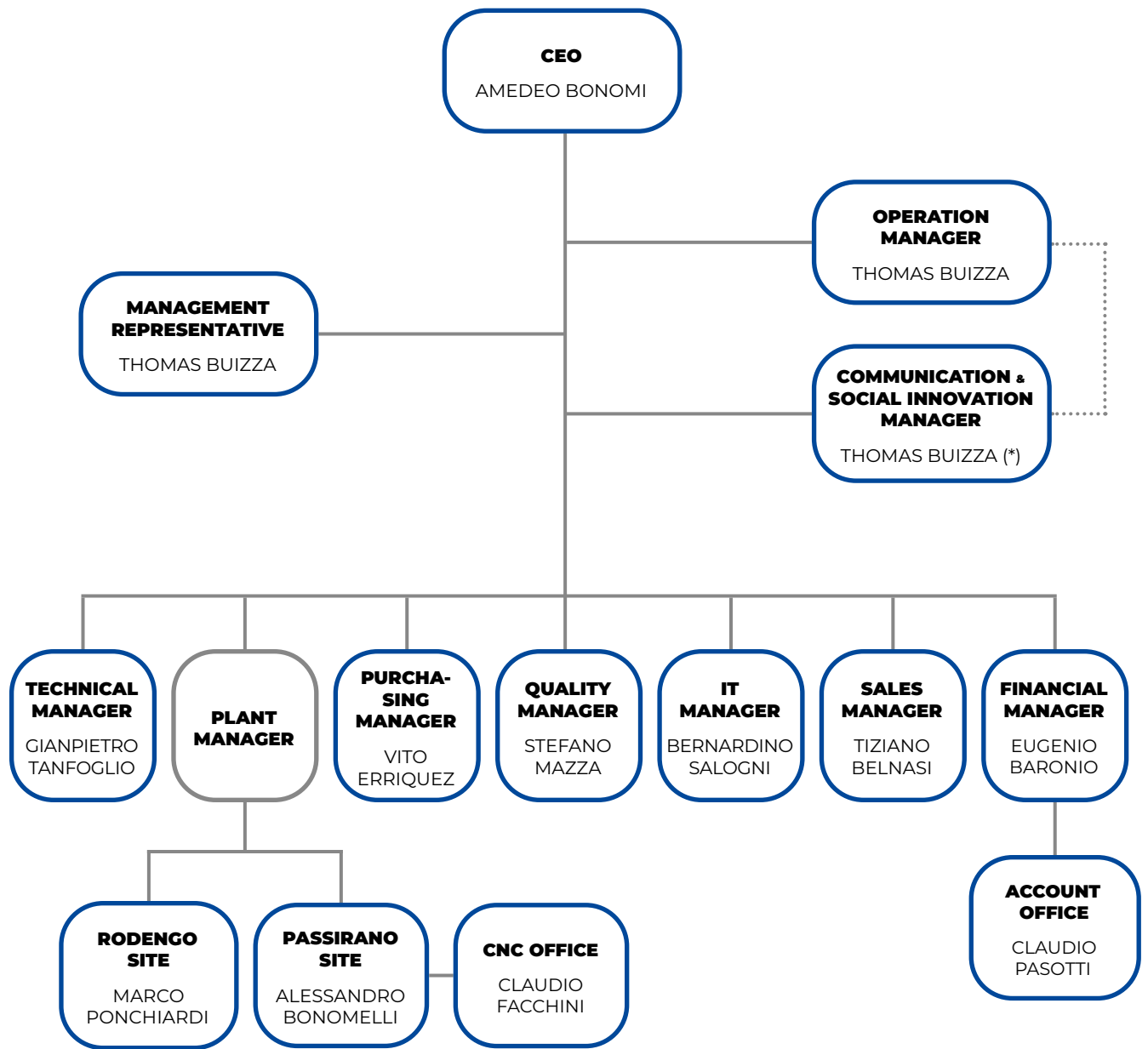

(\*) Interim



## 3.2 ETHICS AT OMAL

OMAL asks its staff to act with integrity and responsibility, respecting the opinions and beliefs of others, and that all behaviour is exemplary.

OMAL staff are required to: not encourage or take part in bullying, mobbing, stalking or humiliating acts, both verbally and physically. To not create conditions that can detract from colleagues' self-esteem or professional reputation. To intervene and contact their manager or management in the event that discriminatory acts against OMAL staff are observed.

Likewise, OMAL respects its employees' freedom to express their ideas and positions, since only by sharing different opinions can we truly work in an enriching environment, where professionals can improve their skills.

- Act fairly and honestly with all counterparties;
- Stimulate innovative thinking and participatory methods for exchanging views and resolving issues, such as new strategies to shape concepts and relationships that can help address problems and setbacks more efficiently and quickly.
- OMAL respects cultural differences and treats every employee with respect and dignity. Race, gender, religious orientation, cultural beliefs, nationality, political opinions, physical conditions or socio-economic origins are seen as enriching variables and should not be used to discriminate against anyone.

## 3.3 ENGAGEMENT

Corporate engagement is one of the objectives of the 2016-2020 strategic plan to increase involvement and a sense of belonging.

The actions implemented in this regard were:

**“Tutti Convocati”** scheme: these are periodic meetings between Management and Top Management to share strategies, objectives and results. In 2019 there were three in-depth study and discussion events on the following issues:

- May 9: MID TERM MEETING - PROJECTS AND ACTIVITIES PROGRESS STATUS
- August 29: JPA PROJECTS / JPA WORKFLOW PRESENTATION
- November 7: PRESENTATION OF THE SALES BUDGET FOR 2020

**Corporate events:** as usual, two events are organised each year during which OMAL meets with employees, discusses specific projects and shares recreational time in a cool location.

The first event extended to all workers and their families was held in July 2019, with a play by Compagni Rossolevante entitled “the virus that saves your life” to raise staff awareness of health and safety at work, an essential aspect for the growth of the organisation.

The second is the traditional Christmas dinner, which includes a moment of sharing and reflection on the progress of the working year concluded with all employees. The event is also extended to retired staff. As per tradition, during the dinner there was a raffle for which the prizes were the gifts received by the company during the year, so they can be shared by everyone.

## 3.4 TRAINING

To support the 2020 strategic plan the following training needs have been defined, described in the company training course called “In FormAzione”, which develops both technical and managerial skills for managers:

Technical skills	Management skills
English language development	Work organisation
Business intelligence	Leadership skills
Management system	Delegating skills

The “In FormAzione” pathway also involves the provision of internal training (company self-training) for the transfer of company skills and/or to support changes in personnel in key roles.

Alongside this four-year project, implemented at a single operation level, there is a higher strategic level that focuses on the efficiency of inter-operation and intra-operation processes, with the aim of moving in a coordinated and efficient way within increasingly complex projects.

In this regard, all unit managers must be able to:

- organise;
- manage;
- measure;

As can be seen from the figure below, in 2019 there was a significant increase in investment in training both in terms of the number of courses carried out, as well as in terms of staff involvement and total hours.

### Employee Training Trends

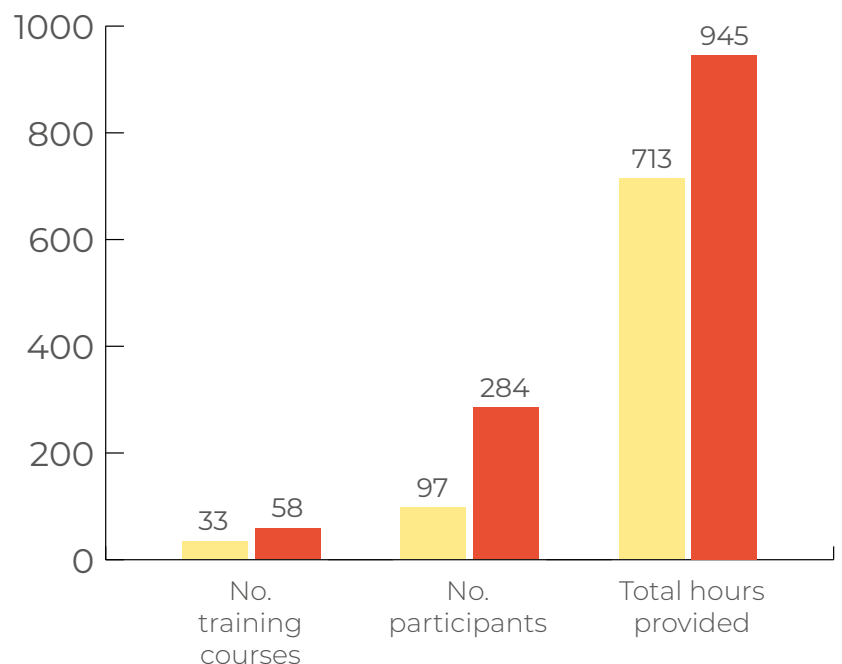
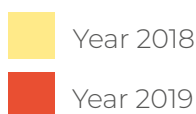

The average hours of training per employee rose from 7.8 hours in 2018 to 9.2 in 2019. Training mainly concerned issues related to quality and worker health and safety, mainly involving workers and employees, mostly men.

Total training hours by topic

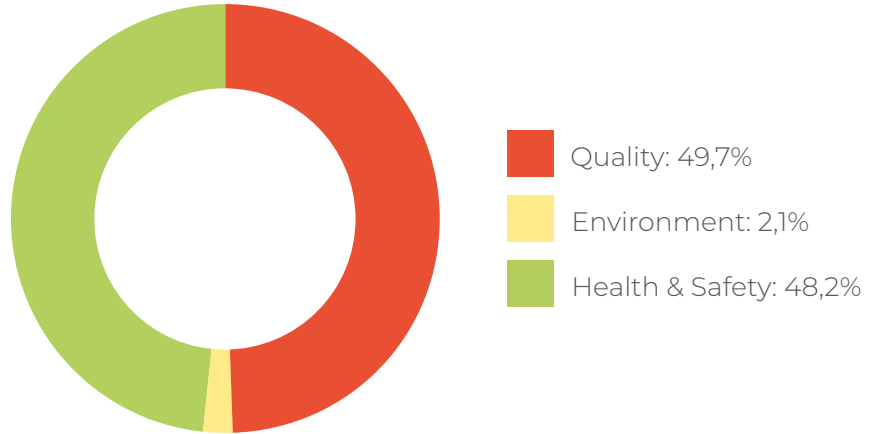

Total training hours by role

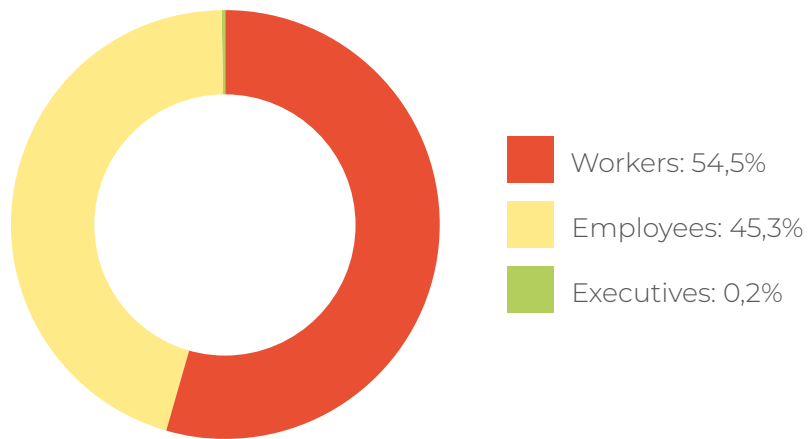

Total training hours by gender

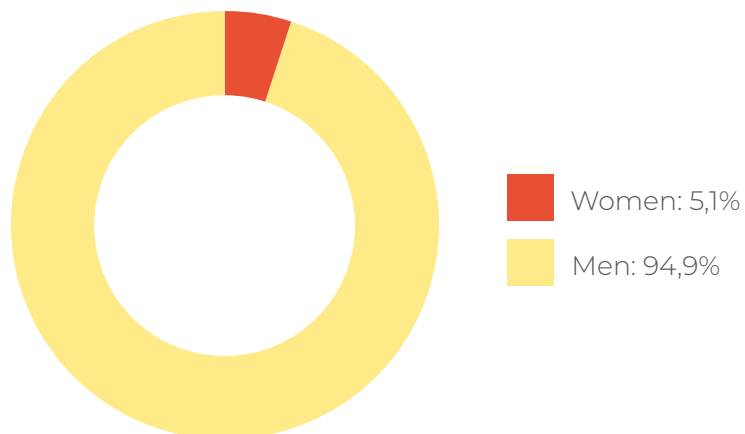

## 3.5 HEALTH AND SAFETY

For OMAL, protecting the health and safety of workers is a priority that has led us to define organisational and operational procedures aimed at reducing exposure to the risks inherent in our business as much as possible.

The aim is to reduce work-related accidents and illnesses, aware that health is important to work well and for a long time.

Period	Average Accident Duration Index DM= d/Kt	Frequency Index IF = d/L x 106	Severity Index IG = Kt/L x 10 <sup>3</sup>
Year 2019	13,0	16,6	0,2
Year 2018	17,0	17,2	0,3
<b>AVERAGE previous three years</b>	15,4	19,3	0,3

The efforts made have yielded very positive results in 2019 with a significant reduction in both the duration, frequency and severity of injuries compared to 2018 and the average over the last three years.

In particular, the accident severity index decreased by more than 50% compared to the previous three years and by more than 30% compared to 2019 alone. All the indices considered are lower than the average for the three-year period, including the use of sick days per employee: therefore the global index (I-SSL) that indicates the trend in health and safety conditions in the work environment is equal to 100.

Occupational health and safety was the central theme of our activities during 2019, specific investments were made to prepare emergency measures and widespread staff training and awareness raising activities were carried out.

In particular:

- We purchased and installed defibrillators at the Passirano and Rodengo Saiano production sites, aware that prompt and effective first aid can be the difference between life and death, between prompt or prolonged recovery, between temporary or permanent disability;
- An emergency team has been trained in the use of AEDs because early intervention within 5 minutes can reduce cardiac damage and save a life;
- Our canteen encourages a balanced and healthy diet with top quality ingredients. Vegetarian dishes are always offered on the daily menu. Meals are booked via the App where you can view the nutritional information and the energy value of the dishes chosen;
- A “Guide to healthy eating” was provided with the 10 rules for healthy eating and a healthy lifestyle taken from the Ministry’s “Guidelines for healthy Italian nutrition”;

In order to raise awareness and engage not only our staff but also their families on health and safety issues, an ad hoc show entitled “the virus that saves your life” was organised.

**EMPOWERED DAY 2019**

**SABATO 6 LUGLIO**

**SPETTACOLO TEATRALE “IL VIRUS CHE TI SALVA LA VITA”**  
COMPAGNIA TEATRALE “ROSSOLEVANTE”  
PRESSO **ORATORIO DI MOMPIANO**  
Parcheggio parrocchia San Caudenzio: Via della Lama, Brescia

ORE 10.45: **RITROVO**  
ORE 11.00: **SPETTACOLO TEATRALE**

.....

**PRANZO** PRESSO RISTORANTE **CASTELLO MALVEZZI**  
Via Colle di San Giuseppe 1, Brescia

ORE 12.30: **APERITIVO IN TERRAZZA**  
ORE 13.00: **PRANZO**

Confermare la propria presenza entro il **26 Giugno 2019** a:

- **Alessandro Bonomelli** per OMAL Passirano
- **Marco Ponchiardi** per OMAL Rodengo Saliano
- **Gabriele Parola** per ACTUATECH Villa Garcia
- **Domenico Maisto** per ACTUATECH Sarezzo

L'argomento trattato nello spettacolo è valido come formazione in materia di salute e sicurezza sul lavoro per ogni partecipante.

## 3.6 WELFARE

**W**e have promoted corporate welfare by encouraging the activation of services reserved for companies that apply the CCNL (National Labour Collective Agreement). There were 27 requests for contributions submitted by OMAL employees mainly for the enrolment of children in various school, book and baby birth orders, for a total amount of 5,250 euros.



## 3.7 COMMUNITY

We want to live in a society capable of sharing knowledge and good practices among all the different actors who carry out their work with a particular attention to ethical values. This is why we are more than happy to communicate our behaviour transparently, in the hope that it will prove that combining fairness and business is not a slogan.

We believe that sharing the values and the path undertaken by OMAL is strategic in order to multiply the positive impact of our actions, sharing them with other actors who could in turn replicate them. This is reflected in OMAL's participation in conferences, thematic meetings and participation in training projects to bring the world of school closer to production companies.

In June 2019 OMAL presented its case history at the conference "Sustainability: a strategic choice for companies" organised by 2A GROUP to raise awareness of sustainable development and the growth opportunities provided by an increasingly green-oriented market. Our Quality & Environmental Manager illustrated the virtuous path undertaken by OMAL over the years and the returns in terms of efficiency, image and economy.

In addition, sharing the way we act with others allows us to innovate our approaches, connecting with new people, smart networks and understanding the needs of our community more deeply. Moreover, for some years now, it has been participating in school-work alternation projects with some high schools in the area, giving children the opportunity to consolidate the knowledge acquired at school, test their aptitude and learn about our working approach.

With the same principle, an internship was launched with a third year student from Bocconi University.

*Nowadays it is increasingly important to recognise ethical values as promoters of "shared virtuous practices", i.e. virtuous attitudes commonly put into practice by a system of different actors but all belonging to the same community.*

**Extract from the OMAL Code of Ethics.**



Presenta il seminario gratuito:

### SOSTENIBILITA' SCELTA STRATEGICA PER LE AZIENDE

27 giugno 2019

Presso Hotel NH Bergamo  
Via Paleocapa, 1/G Bergamo (BG)

#### OBIETTIVI

- Comprendere le opportunità di crescita offerte da una domanda di mercato sempre più green oriented
- Capire come quantificare la sostenibilità dei propri prodotti e/o della propria azienda e implementare efficacemente le azioni di miglioramento
- Comunicare con successo i risultati ottenuti, evitando di cadere nel rischio di green washing

#### DESTINATARI

Titolari d'Azienda, Responsabili HSE, Responsabili Marketing e Comunicazione

#### PROGRAMMA:

ORE 9.00: Accoglienza e registrazione partecipanti  
ORE 9.15: Apertura lavori e presentazione dell'incontro  
ORE 9.20: Sviluppo Sostenibile: definizione, contesto, quadro normativo - Dott. Francesco Dodaro  
ORE 9.50: Il percorso della sostenibilità, vantaggi delle etichette ambientali, le certificazioni - Dott.ssa Luisa Tranquilli  
ORE 10.30: Principi di economia circolare e azioni di ottimizzazione in azienda - Ing. Alessandro Rocca  
ORE 11.00: Coffee break  
ORE 11.15: Tavola rotonda: l'esperienza di BMS Micronutrients, Conceria Superior, OMAL e PE.DI a confronto  
ORE 12.15 La sostenibilità del nostro evento - Davide Laffranchi  
ORE 12.30 Domande e dibattito  
ORE 13.00 Chiusura lavori



MAIN OFFICE  
Via Gorizia 26  
24041 Brembate  
(BG)  
Tel 035 802107  
Fax 035 802347  
info@2a-group.it  
www.2a-group.it

## 3.8 PHILANTHROPY

OMAL is aware of its economic and social role in the areas of Franciacorta and Val Trompia, where its facilities are based. The company therefore listens to the area and, where possible, responds to the needs of local associations and institutions in order to contribute to the public good and the protection of disadvantaged people.

**Philanthropy** has been, and continues to be, one of the channels of intervention to cope with extraordinary emergencies in one's own territory or country, or to support issues particularly close to one's heart, such as youth sport and disability.

Philanthropy at OMAL is not for marketing purposes, but represents a commitment motivated by emergency or particularly worthy needs.

During 2019, OMAL's philanthropic projects were:

### I CENTURIONI RUGBY

The donation has contributed to the organisational and sporting management of all men's rugby categories from Under 6s to Under 18s. It made it possible to carry out the "Schools Project" to raise awareness and promote this sport among young people and to convey educational concepts based on inclusion, respect and equality. It has given support to families by upgrading the transport service on training days.



### FLAG FOOTBALL

The company has renewed its commitment to support the sports and educational project of Flag Football junior, aimed at boys and girls from 6 to 17 years of age with the aim of encouraging younger people to take part in sport, especially young people from disadvantaged families who have thus been able to show their talent.



## I BAMBINI DELLE FATE

Since 2011 OMAL has supported the **I Bambini delle Fate per Inclusione Sociale** (Fairy Children for Social Inclusion) association which deals with **social communication and fundraising for inclusion and autonomy projects** aimed at improving the life of families experiencing the challenge of autism and disability.



## OTHER DONATIONS

**Medical car** for the Municipality of Rodengo Soiano.

**Centro Mamre** deals with ethnopsychiatry, psychotherapy and psychological support, cultural mediation and prevention of mental and social discomfort for Italian and migrant people and families.

Find below the financial investment for these activities:

Amounts donated	2018	2019
Philanthropy and donations	81.000,00 €	68.700,00 €

Which, while remaining significant, experienced a small decline.









QUALITY

4

## EMPOWERED PERFORMANCE: SYNONYM FOR QUALITY

### Material issues

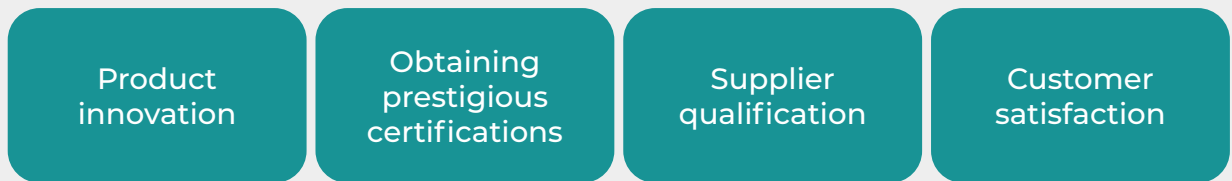

At OMAL quality is an integral part of the company strategy, it concerns the whole company because improving every day is a choice. It is a philosophy that embraces the entire supply chain and the entire production cycle, in order to always provide empowered performance.

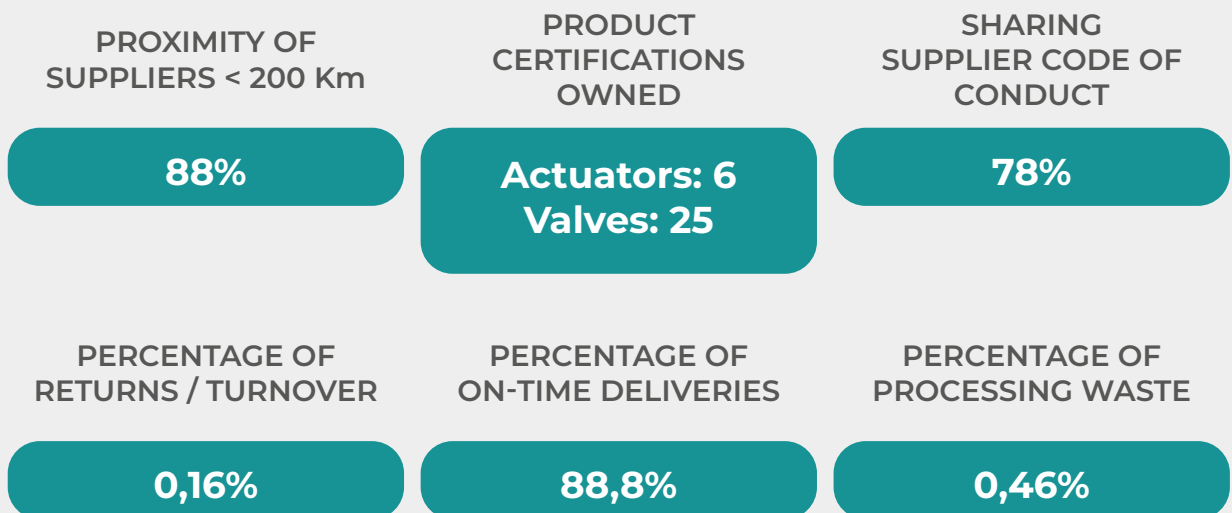

### Reference Goal - GRI (Global Reporting Initiative)



# 4.1 THE VALUE OF QUALITY

A product with empowered performance can only be guaranteed by a production process aimed at continuous improvement, which controls and monitors the effectiveness and the efficiency of the individual processes, which internalises the processing stages to have full control and which automates the production lines to ensure maximum precision. For OMAL, quality also means using the best raw materials and selecting its suppliers according to increasingly demanding criteria. Furthermore, constantly training and updating its staff to encourage professional growth.

The quality of the production process has been guaranteed since 1992 with the certification of our Quality Management System according to the UNI EN ISO 9001:2015 standard.



ISO 9001 Certification ▶



A strategic choice that helps the organisation to improve its performance, to make its production processes more efficient, to correctly manage risks and development opportunities according to the corporate pay off “Empowered performance”.

“Responsible Quality” is the added value of our product. We believe that our customer’s satisfaction can be increased by the attention we pay to the context and the environment in which we operate, respecting the expectations of all those involved, both internal and external.

In 2012 OMAL also certified its Environmental Management System according to the UNI EN ISO 14001 standard.

◀ ISO 14001 Certification

#### 4. QUALITY

The implementation and daily application of the Management Systems guarantee high performance of all the activities that affect the quality of the product and the service provided, in particular:

- ① Effectiveness and efficiency of internal processes;
- ② Continuous improvement of business performance;
- ③ Regulatory compliance;
- ④ Control over environmental impacts and respect for the environment;
- ⑤ Identification of areas of risk and opportunity for the organisation;
- ⑥ Prevention or reduction of unwanted or unexpected effects;
- ⑦ Dynamic, innovative management model oriented towards customer loyalty;

This integrated and systemic approach is in line with OMAL's way of operating, which has always asked management and organisational questions in order to offer customers a product or service that conforms to the best international standards.

Our quality policy was updated during 2019.

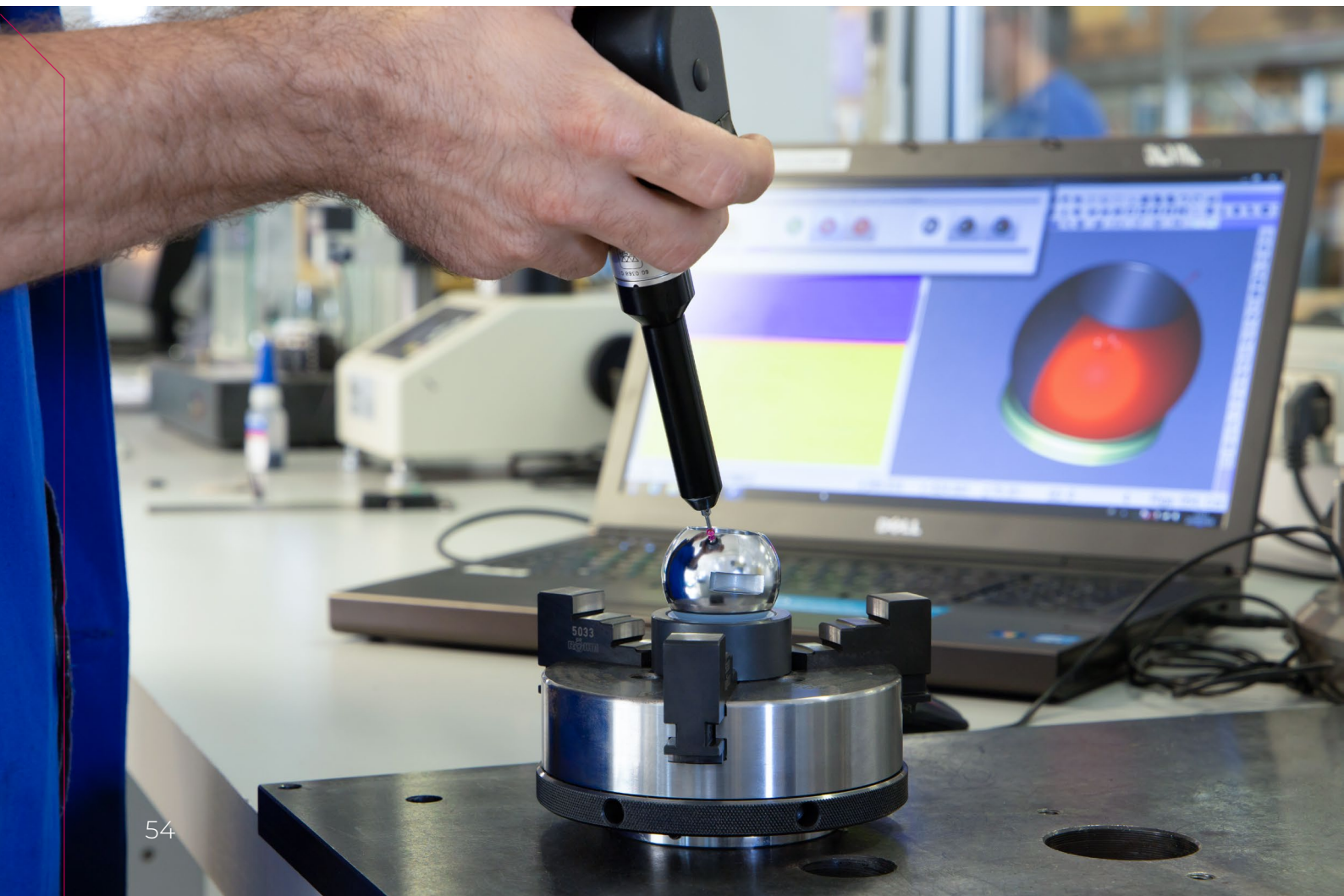



EMPOWERED PERFORMANCE

OMAL S.p.A.

Headquarters: Via Ponte Nuovo 11, 25050 Rodengo Saiano Brescia Italy

Production Site: Via Brognolo 12, 25050 Passirano Brescia Italy

Ph: +39 0308900145 Fax: +39 0308900423 VAT nr. 00645720988

Web Site: www.omal.it E-mail: info@omal.it

## QUALITY POLICY

Omial has always based its expansion and its development on the high quality of the products and the service offered on the market, as per our Pay Off *Empowered Performance*.

OMAL believes that the continuous improvement is an essential factor for success that intends to pursue according following basic principles:

- **Consider the context of the organisation:** know the internal and external issues that can impact on strategic objectives and on the Quality Management System of OMAL, the factors and conditions that can affect products, services, investments and interested parties or be affected by them.
- **Consider the interested parties:** understanding the needs and the expectations of the interested parties, analyzing and answering to their present and future needs, offering products, solutions and services, able not only to meet the requirements, but also to overcome the market expectations, strengthens our ability to maintain and promote new investments, the vitality and continuous development of the our organization and increase our competitiveness and the trust in the OMAL brand.
- **Establish unity of purpose and direction of the organization through the involvement of Process Managers and employees all:** create and maintain an internal work environment that can become fully involved in achieving the organization's objectives.
- **Manufacture products at the level of the world's best competitors:** for the process industry and in particular for the Oil & Gas industry, able to meet market requests, in compliance with national and international standards (e.g. API6D, ASME, EN, ISO...).
- **Manage business activities and resources as a controlled process:** monitor the processes effectiveness and efficiency, establish improvement objectives and key performance indicators to measure their achievement.
- **Respect the national and international applicable laws,** concerning the product safety (i.e. PED, ATEX, MD European Directives for CE marking), the health and the workers safety protection, the environment safeguard and the social responsibility principles promotion.
- **Identify any risks and opportunities that could affect the effectiveness of the quality management system:** Identify and analyze the potential risk and evaluate the opportunities of improvement in the business process, assess and mitigate and establish contingency planning, to ensure the product conformity and the customer requirements satisfaction.





EMPOWERED PERFORMANCE

OMAL S.p.A.

Headquarters: Via Ponte Nuovo 11, 25050 Rodengo Saiano Brescia Italy

Production Site: Via Brognolo 12, 25050 Passirano Brescia Italy

Ph: +39 0308900145 Fax: +39 0308900423 VAT nr. 00645720988

Web Site: [www.omal.it](http://www.omal.it) E-mail: [info@omal.it](mailto:info@omal.it)

- **Improve the internal and external communications of the organization:** promote the information and the formation at every level in order to promote the increase of individual skills, the sharing of knowledge and experiences for continuous improvement.
- **Improve flexibility and readiness to give consistent responses to changing market or to the interested parties expectation:** select suppliers sensitive to the fundamental concept of quality, sustainability and collaborating in the service as a primary value.

According to these principles, OMAL promotes the continued increase of the organization planning and implementing, through the Quality Management System, the objectives and the resources for achieving them, ensuring communication and employees involvement, a continuous monitoring of processes and activities with impact on the quality of the products and services provided.

The management of environmental impacts, the Sustainability, the Corporate Social Responsibility, the Social Innovation and the Health and Safety Protection, constitute the fundamentals elements of OMAL strategy inspired by the core values of Omal: **Passion, Respect and Sense of Duty.**

Omal look to the future with the awareness that *The right balance between human and environment improves the quality of the life, ensuring a better world for future generations.*

The Mission that we respect every day makes us credible and reliable actors because *With the valves & actuators we manufacture we take care of the environment and we improve the quality of the life making safer and more reliable plants.*

Rodengo Saiano, 01 August 2019

A. Bonomi

CEO

A handwritten signature in blue ink, appearing to read "A. Bonomi", is positioned below the printed name and title.





## FOCUS: API Q1 CERTIFICATION

Another important certification achieved by OMAL is the API Q1 specification. This is a company-wide certification based on the standard developed and published by the **American Petroleum Institute (API)** entitled *"Specification for quality management system requirements for manufacturing organizations for the petroleum and natural gas industry"*.

This certification is intended for companies that manufacture equipment or components of equipment used in the production of petroleum and natural gas. The certificates are issued exclusively by API after the positive outcome of an on-site audit to verify the correct implementation of the quality system and all the risk mitigation procedures indicated in the standard, as well as constant compliance with the requirements. To maintain the certification it is necessary to repeat the audit annually, the next one is scheduled for mid-2020.



The advantages of the API Q1 specification are many:

- minimisation of the risk of supplying non-compliant products and guarantee to the customer of constant product quality;
- maximisation of management by improving productivity, reducing waste and guaranteeing on-time deliveries;
- ensuring that customer requirements are clearly defined, communicated and understood prior to their management;
- optimisation of corporate processes and standards and consequently of corporate competitiveness.

In addition, OMAL's overall approach to continuous improvement and its focus on defect prevention has enabled it to successfully pursue its mission of providing empowered products.

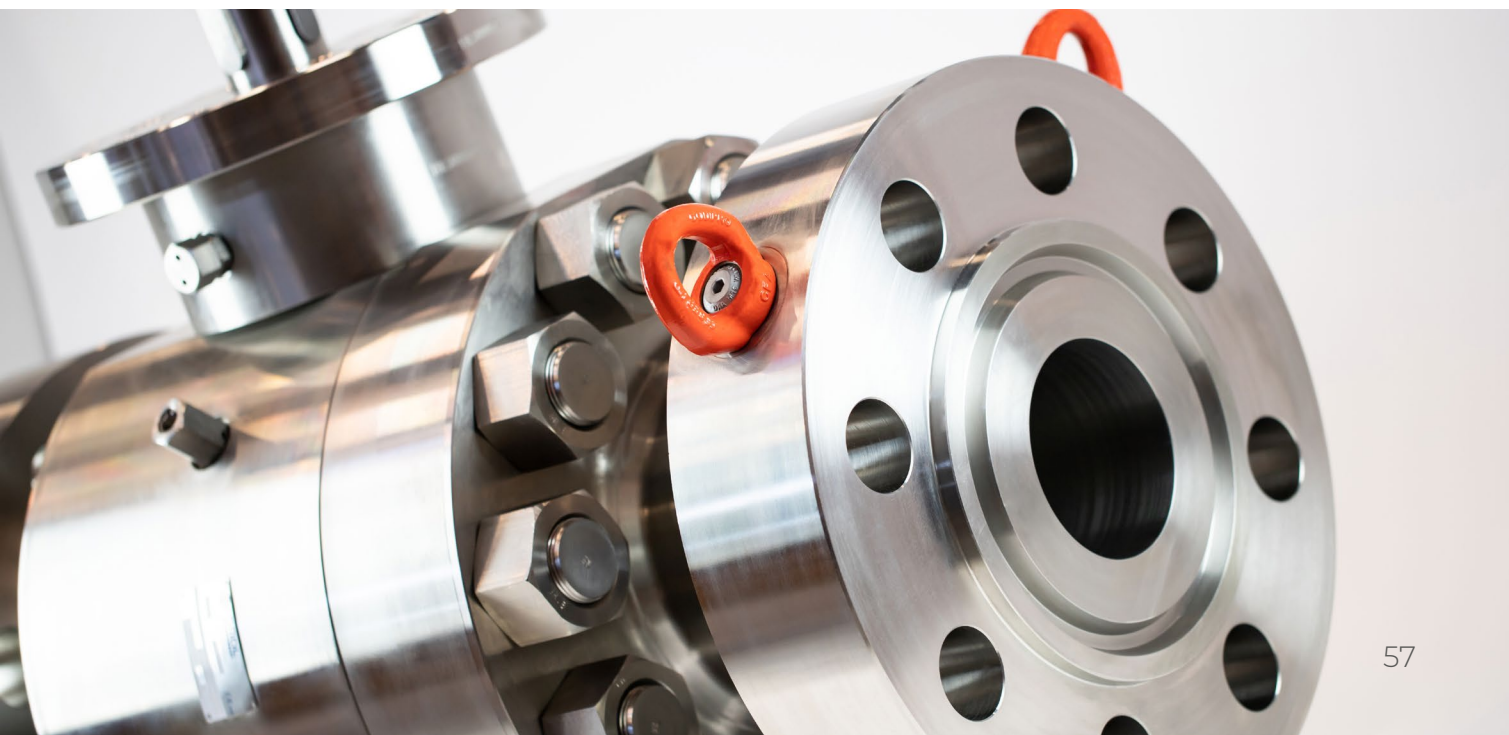

## 4.2 THE IMPORTANCE OF DESIGN

Since its inception, for OMAL design has represented the added value of its valves, focused on the pursuit of increasingly advanced performance.

We are a solution provider. Our team of experts in the field of co-engineering is able to design the best combination of valves and actuators and all the other accessory elements needed to best control the intercepted fluid.

Our main objective is to create a high-performance, efficient and reliable valve that meets sustainability criteria at the same time: maximum service life, maintainability, low energy consumption during use, easy disassembly at the end of its life for proper disposal are the factors we strive for to reduce the environmental impact of our product.

To pursue these objectives, we constantly invest in:

### RESEARCH AND DEVELOPMENT

OMAL has always focused on the innovation of its product thanks to the collaboration of a team of highly specialised engineers and technicians. Our test room allows us to test and stress prototypes, components or finished products for continuous verification of our product's performance. In addition, thanks to collaborations with university institutions such as the University of Brescia, the company is also involved in technical projects and welcomes students into the company.

### SPECIFIC SIMULATION SOFTWARE

Solidworks Flow Simulation software allows you to simulate the flow of liquids and gases under real-life conditions, run hypothetical scenarios and efficiently analyse the effects of fluid flow, heat transfer and related forces on submerged or surrounding components, which are key elements in the creation of innovative, high-performance products.

### AESTHETICS

OMAL's commitment to offer its customers an innovative product with high technical performance is also reflected in its attention to detail and the quality of the shapes. Thanks to the collaboration established a few years ago with the ITALDESIGN - GIUGIARO S.p.A design studio, the added value of the design of our product starts from the style, going on to enrich the development of its functions, imagining its final application within broader boundaries.

## RACKON Rack and pinion pneumatic actuator

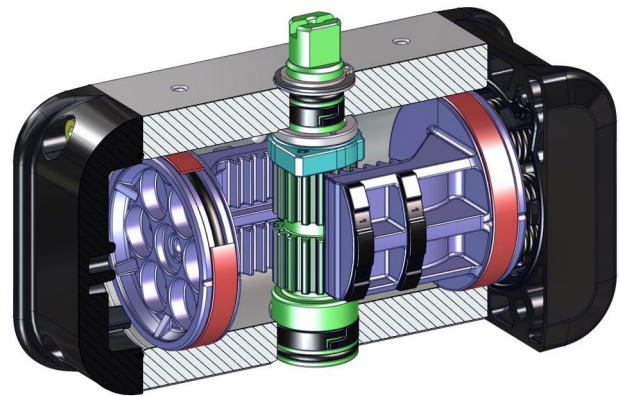

## VIP EVO pneumatic valve

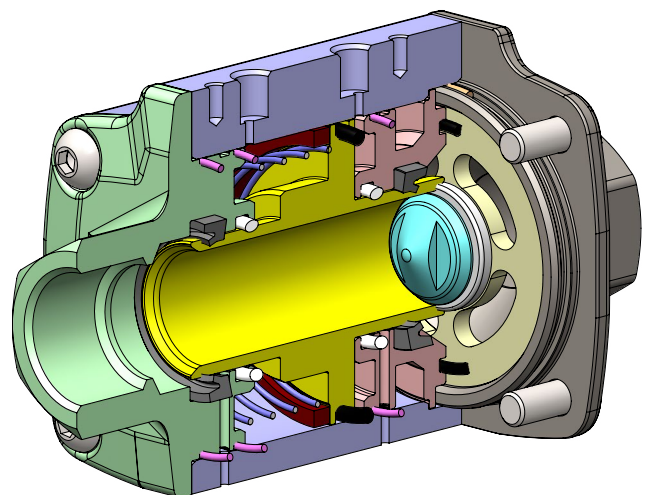

It is within this philosophy that OMAL embodies its commitment to its customers so that the design effort generates reliable and beautiful solutions, therefore different and distinguishable, in one word: empowered.

## 4.3 OUR PRODUCT

The valve is a mechanical component that intercepts or regulates the flow of a material able to flow through a pipe in order to guarantee specific pressure or flow values. The intercepted material can be solid (powders, flours) or, as in the vast majority of cases, a fluid (a liquid or a gas). The materials intercepted can therefore be distinguished between hazardous or non-hazardous.

OMAL designs and manufactures industrial valves suitable to be used in many applications and sectors and able to meet the functional safety standards foreseen for the process industry and to ensure the safety requirements of the plants they are part of.

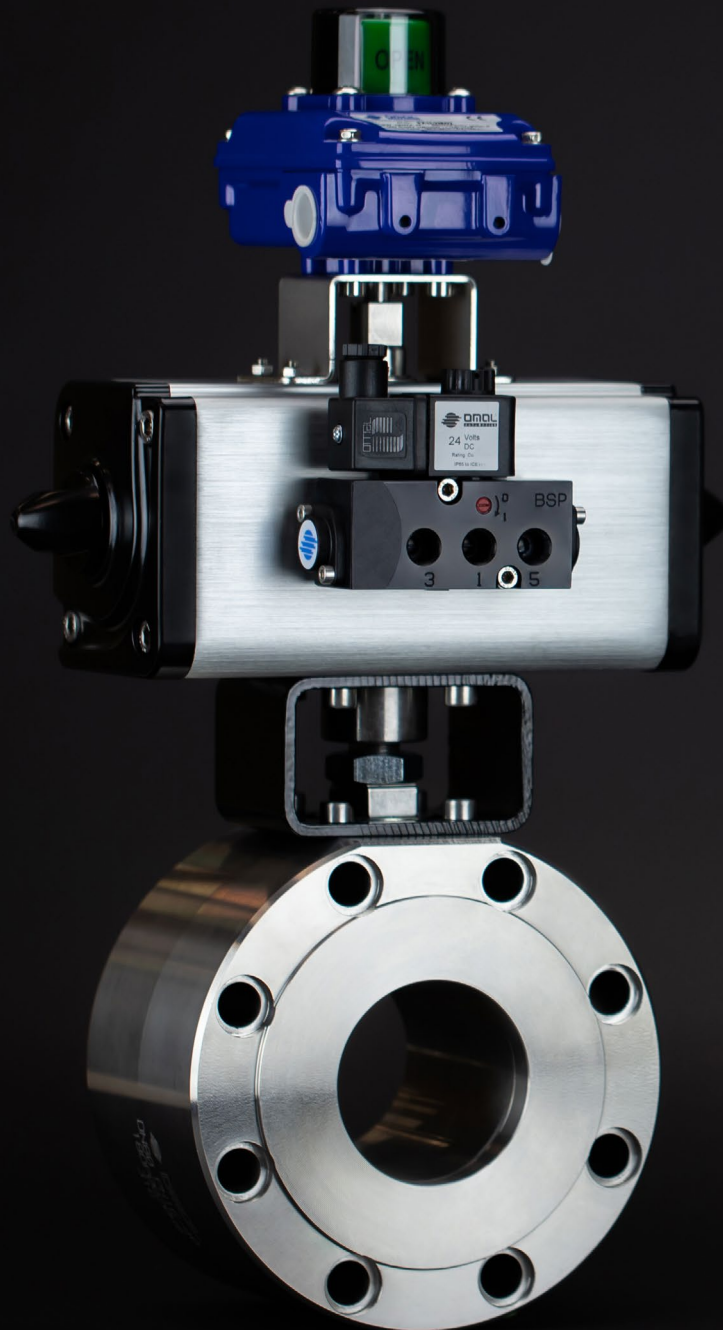

OMAL products' main applications for use are:

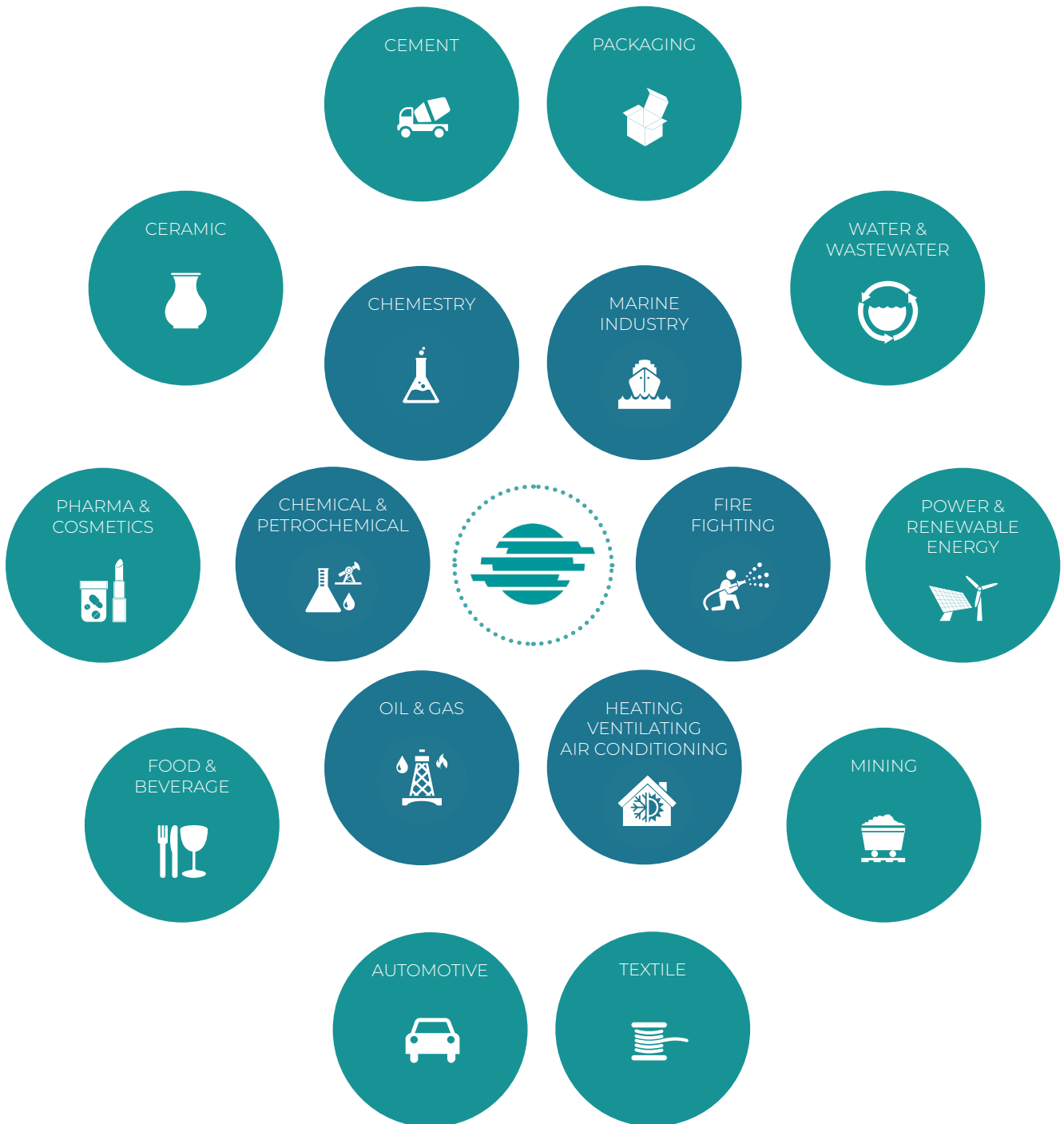

# FOCUS: 4 NEW PRODUCTS

## DAN and SRN actuators

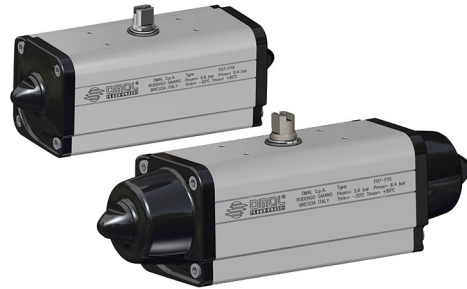

These actuators adopt the *Scotch yoke* mechanism to transform the linear force of the pistons into a twisting force. This system allows a long actuator life and the best performance with minimum energy consumption. They are available both in the double acting “DAN” version and in the single acting “SRN” version with spring return.

## RACKON actuators



It uses Rack & Pinion kinematics to convert the linear motion of the pistons into rotary shaft motion, with a rotation angle from 0° (valve closed) to 90° (valve open) and vice versa. Versions with clockwise and counterclockwise closing are available.

## VIP EVO valve



It is an automatic fluid interception (on/off) device which includes both the control device (pneumatically operated) and the fluid interception device. Careful design has made it possible to reduce its weight and overall dimensions and to guarantee a high number of opening and closing manoeuvres. Furthermore, the study of internal fluid dynamics has made it possible to minimise turbulence and pressure drops.

## KRATOS valve



It is a high pressure ball valve designed to intercept a wide range of fluids (both self-lubricating and non-self-lubricating). It is designed to withstand a high number of drive cycles (HIGH CYCLICITY) and therefore to be automated. The version made with corrosion-resistant materials allows heavy use and in the presence of aggressive fluids.

## 4.4 CERTIFICATIONS

In line with the company Mission “We guarantee a better world for our children. Thanks to our products we protect the environment around us and effectively improve the quality of life by making systems safer and more reliable” OMAL believes in the importance of its product certifications to best convey the value of its brand.

Product certifications are acquired in agreement between the Head of the Integrated Management System, the Head of Sales, the Head of Design and the General Management.

OMAL boasts an extensive series of product certifications applied to the four main families:

### BALL VALVES



- Certificate of compliance with Directive 2014/68/EU PED;
- Compliance with Directive 2014-34-EU ATEX;
- API6D Certificate;
- Certificate EAC TR CU 010/2011 and Certificate EAC Ex TR CU 012/2011 and Certificate EAC TR CU 032/2013;
- UKR Certificate;
- FIRE SAFE API607/ISO10497 Certificate;
- FUGITIVE EMISSION EN ISO 15848 Certificate;
- TA-LUFT Certificate;
- SIL3 IEC 61508 Certificate;
- ADR - EN14432 Approval;
- IGR Approval;

### BUTTERFLY VALVES



- DIN DVGW Certificate for GAS EN 13774;
- Certificate of compliance with Directive 2014/68/EU PED;
- Compliance with Directive 2014-34-EU ATEX;
- RINA MAC242716CS Certificate;
- EAC Ex TR CU 012/2011 Certificate;
- EAC TR CU 032/2013 Certificate;
- UKR SEPRO Certificate;
- ADR - EN 14432 Approval;

### PNEUMATIC VALVES



- Certificate of compliance with Directive 2014/68/EU PED;
- Compliance with Directive 2014-34-EU ATEX;
- EAC TR CU 010/2011 Certificate;
- EAC Ex TR CU 012/2011 Certificate;
- EAC TR CU 032/2013 Certificate;
- UKR Certificate;



## ACTUATORS

- Compliance with Directive 2014-34-EU ATEX;
- SIL3 IEC 61508 Certificate;
- Certificate EAC TR CU 010/2011;
- Certificate EAC Ex TR CU 012/2011;
- UKR Certificate;
- TAP00001G5 Certificate;

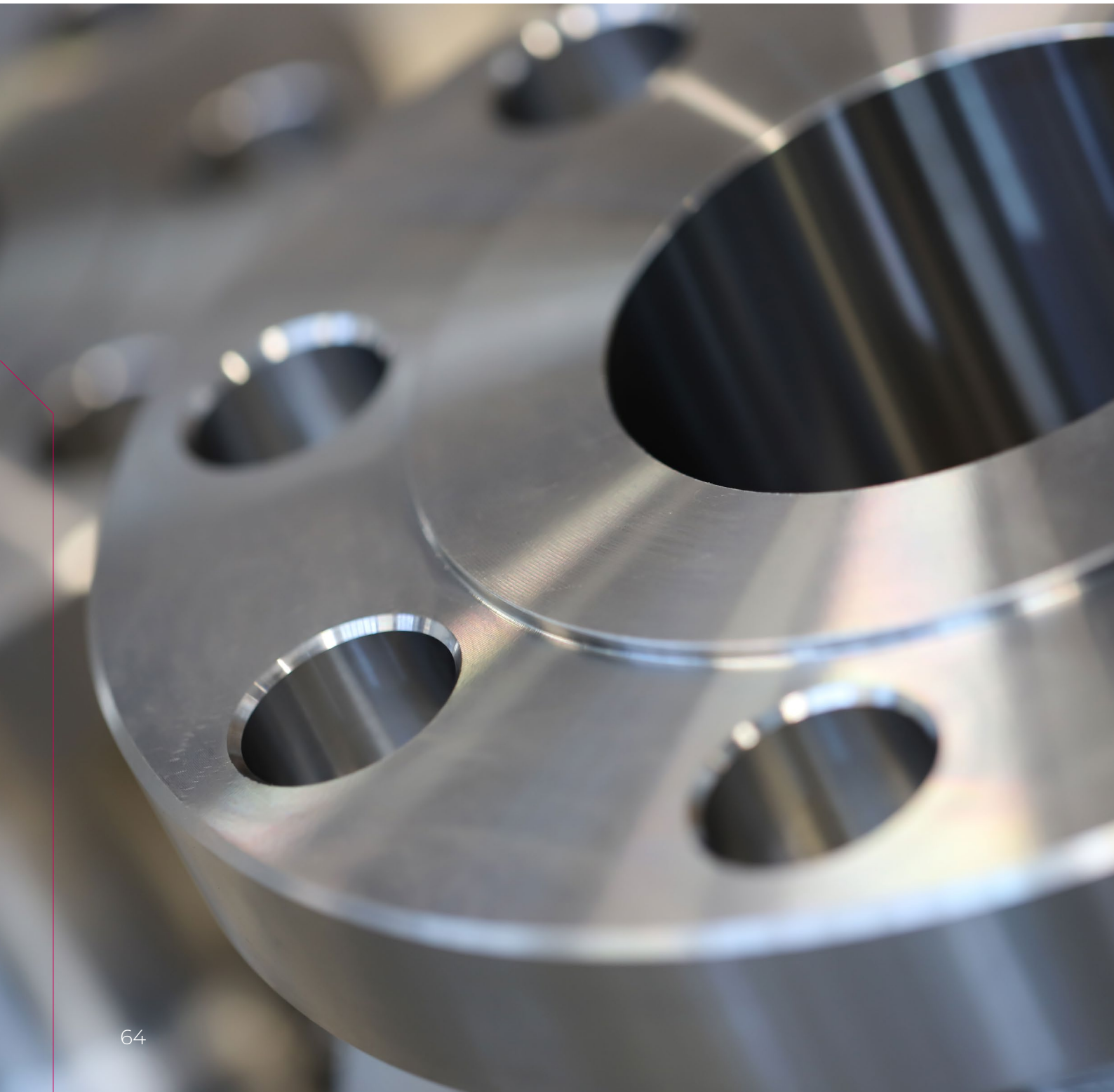





# 4.5 PRODUCTION PROCESS

At OMAL the production unit is located at the Passirano facility, built according to the best environmental and architectural standards. Since 2016 it has been the hub where OMAL valves and actuators are born, from the technical drawing to the finished product ready for use.

To pursue the objectives of our strategic plan, we have directed our investments towards:

- Automation
- Internet of Things
- Business intelligence
- In House process & made in



## PROCESS AUTOMATION

Considerable investments have been made in recent years to achieve an important level of automation at the Passirano and Rodengo Saiano sites with the construction of automated work stations, many of which are robotic. This has had many positive repercussions on management thanks to greater control and efficiency in production processes, optimisation of consumption and energy savings, as well as on the quality of the final product.

Provision of machinery and work stations

- Year 2018
- Year 2019

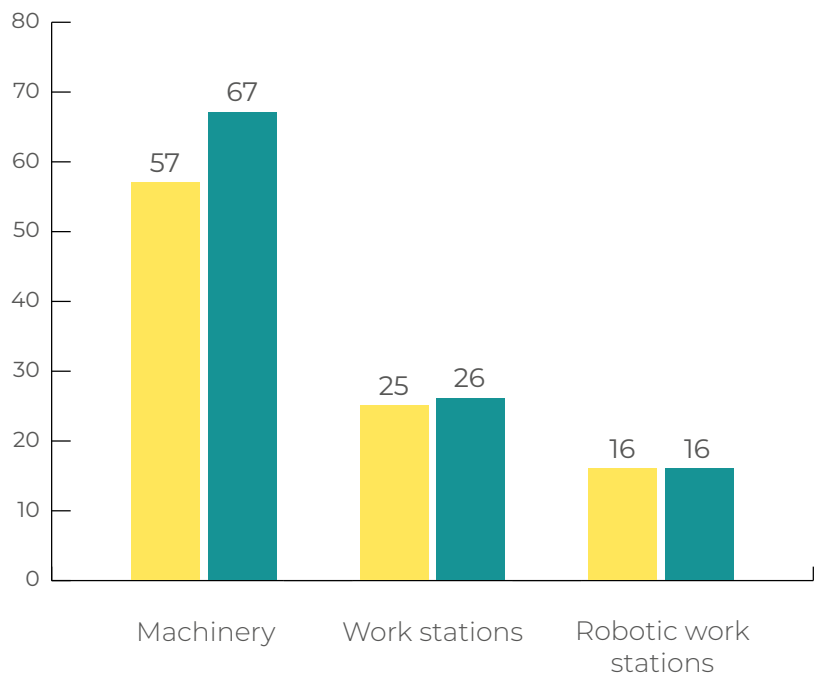

The main investments in 2019 concerned the construction of:

- an automatic warehouse for the storage of brass and steel bars that guarantees traceability and the best conditions for the product, as well as operator safety;
- an automatic material handling warehouse, conceived according to IoT principles, with vehicles equipped with a mixed “track” and “free” driving system which, thanks to the use of inductive and laser navigation technologies, allows them to move easily within corridors, between racks and to circulate in the warehouse without the guidance or intervention of an operator;

## INTERNET OF THINGS

IoT is a technology that makes it possible to maximise the capacity for collecting and communicating data from a multitude of sources (intelligent objects, machines, robotic work stations...) by networking them, including remotely, for the benefit of greater digitisation and process automation. Collecting and processing this data helps us to monitor performance, supervise processes and extract useful information for decision-making.

MOVICON 11 (monitoring vision and control) has been adopted at the Passirano and Rodengo Saiano facilities, an application capable of statistically analysing the downtime on the plants, classifying them by production period. Data analysis allows us to quickly identify critical points in the production process and improve them in order to achieve maximum system efficiency and productivity. In addition, the Movicon Pro-Energy module, activated in 2019, allows the detection and management of the energy consumption of each production plant.

## BUSINESS INTELLIGENCE

Continuous improvement is based on the principle that “You can only improve what can be measured”. User friendly analysis tools, such as the JPA, Qlik view and Qlik sense applications adopted allow us to make decisions in real time, guaranteeing an immediate response. In particular, the JPA software is a Project Management system that allows coordinated management of activities, from the planning and progress phase to their closure. JPA also manages some critical or strategic “internal processes” by distributing responsibilities and activities through a specific work-flow in order to speed up the relationships between internal processes and manage them in a more controlled manner.

This is very useful for those processes that have ad-hoc regulations or certifications such as the management of orders for countries subject to trade restrictions, or towards which specific regulations on the circulation of goods operate (e.g. DUAL USE Reg).

## IN HOUSE PROCESS & MADE IN

In order to increase control over the entire process, a new work station was created for cutting and sandblasting aluminium components, bringing processing in house, with significant management advantages.

The strategic processes that characterise the value of our product and that OMAL has always kept self made in are:

**Die casting** in the actuator the cast components are the heart of the product, for this reason OMAL has specialised in aluminium die casting. The sheer size of our automated press fleet allows us to print hundreds of thousands of aluminium components for our actuators and valves.

**Plastic material moulding** a plant for the injection moulding of plastic materials guarantees a high level of quality in the production of certain parts of OMAL products.

**Mechanical Machining** thanks to a fleet of cutting-edge machines and automated processes, OMAL is able to supply products with excellent performance. We are therefore able to perform mechanical machining with precision and a very large variety of materials for which specific expertise is required: steel, aluminium, brass and bronze.

**Assembly and testing** each OMAL product undergoes rigorous checks before being marketed and distributed. Automated test benches are installed in the assembly department to allow for strict product control and testing. We also guarantee the best valve-actuator combinations.

.....



# FOCUS: PRO056 ROBOTIC STATION FOR CUTTING ALUMINUM PROFILES AND SANDBLASTING

The installation of the PRO 056 robotic line was completed at the end of 2019. The new line consists of an automatic cutting system for aluminium profiles (TR) and subsequent automatic sandblasting and palletising of the bodies of the OMAL pneumatic actuators.

The line is completely automated through the use of two anthropomorphic robots which respectively (UD) load the pieces, which come from the cutting system via a conveyor belt, into the sandblaster (TV) and unloading (UE) after sandblasting and storage on pallets for subsequent automatic packaging (UC). The material is stored or sent to the mechanical processing departments.

The automatic system guarantees operator safety, the control and maximum efficiency of the process and the quality of the product, as well as its protection during the subsequent handling phases.

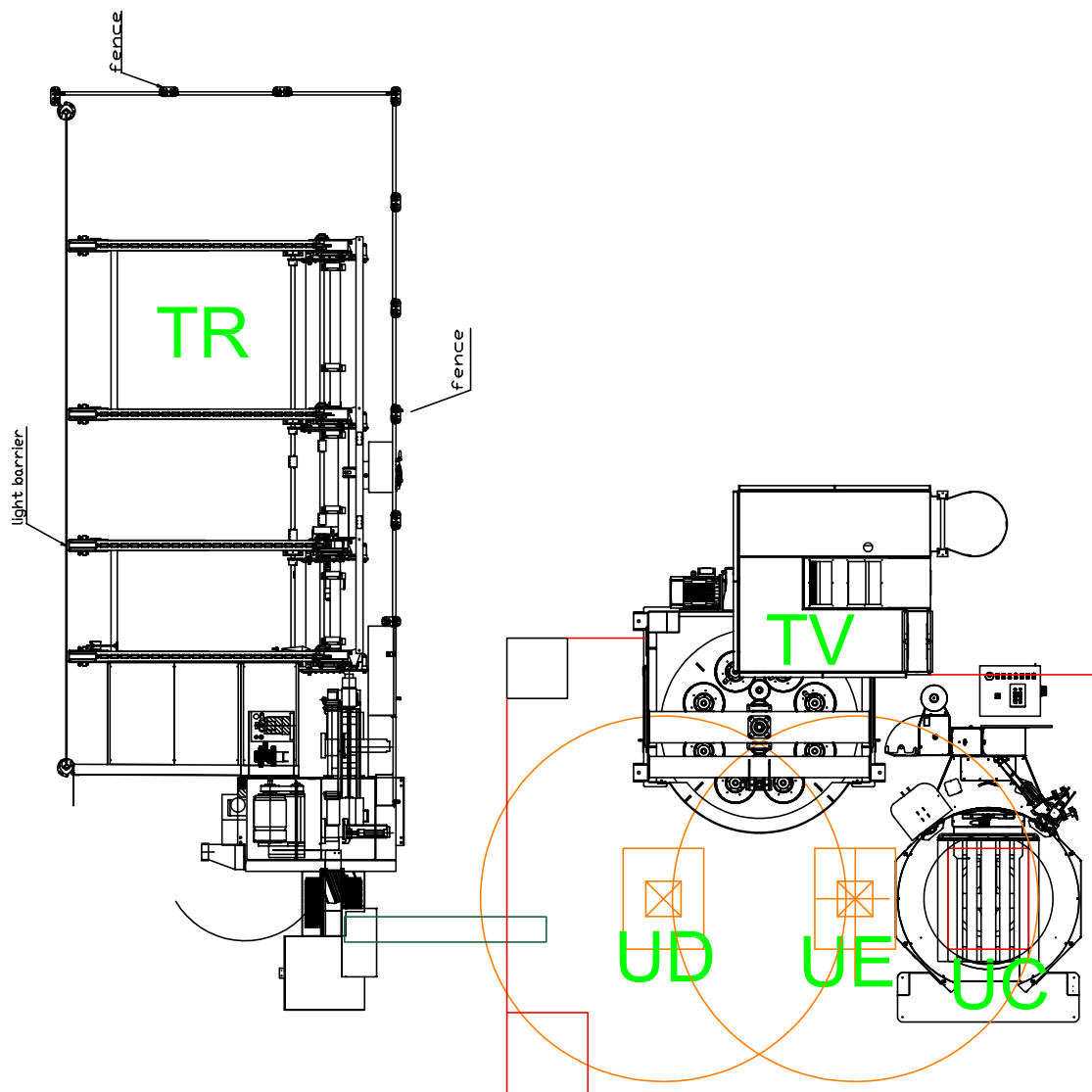

## FOCUS: SMART FACTORY

The SMART FACTORY project was born with the aim of fully digitising the company to innovate it with a view to Industry 4.0. This goes beyond more traditional automation, involving a completely connected, flexible and intelligent system capable of also generating new business models supported by enabling technologies such as IoT and digital intelligence, which focus on the following aspects:

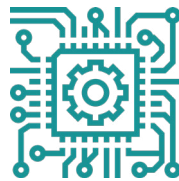

### INTELLIGENT ROBOTISATION

This involved the bar warehouse, production, assembly and logistics with two new ADVs.



### BUSINESS INTELLIGENCE

Thanks to project and process management applications (such as JPA, Qlik view, Qlik sense, Measurlink and EPDM...) information is collected and shared in real time to support decision-making and to intervene promptly.



### DEVELOPMENT OF OMNI-CHANNEL SYSTEMS

To use multiple integrated channels to communicate, promote and sell our products thanks to the new product configurator contained in our website and the OMAL CATALOGUE app developed to allow easy access to information on OMAL products with any device connected to the network.



## ZERO PAPER PROJECT

This approach, which has now become established practice in the company, has led to a system of widespread digitisation of documentation and its archiving. In addition, the development of apps such as Info Day Pocket allows the complete IT management of personnel.



## 4.6 QUALITY SUPPLIERS AND RAW MATERIALS

The quality of a company can be measured by the care with which raw materials are chosen.

The selection of materials with which to make valves and actuators assumes the utmost importance when it comes to offering a product characterised by high performance and reliability. The definition of strict procedures for the selection of qualified suppliers and top quality incoming materials, allow us to trace all the production steps and to process highly controlled and high performance metals and plastics.

To select and qualify suppliers, the Purchasing Department uses a special evaluation form to assess quality, production control and environmental requirements.

Depending on the nature and level of criticality of the product/service supplied, an assessment is then made of the supplier's reliability. In 2019, there was a decrease in the number of non-conformities found compared to the previous year, thanks to the strict supplier selection policy implemented.

OMAL has also established an annual supplier audit plan.

The quality level of the supplies purchased is periodically assessed through two performance indices:





### Supply quality indices

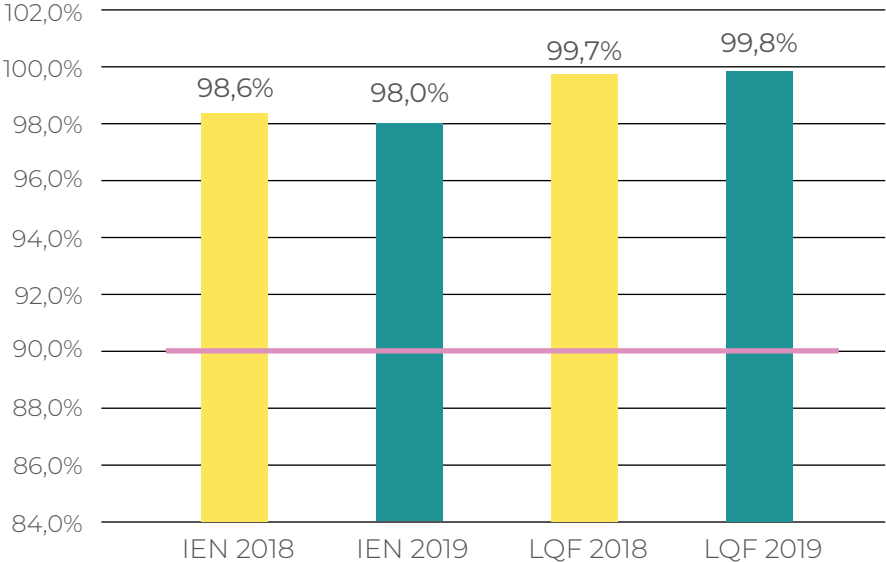

The supplier code of conduct has been shared with the entire supply chain.



## FOCUS: SUPPLIER CODE OF CONDUCT

From 2016, OMAL has started a project to raise the awareness of its supply chain on corporate social responsibility issues by sharing a Supplier Code of Conduct based on the five principles summarised in the following image:

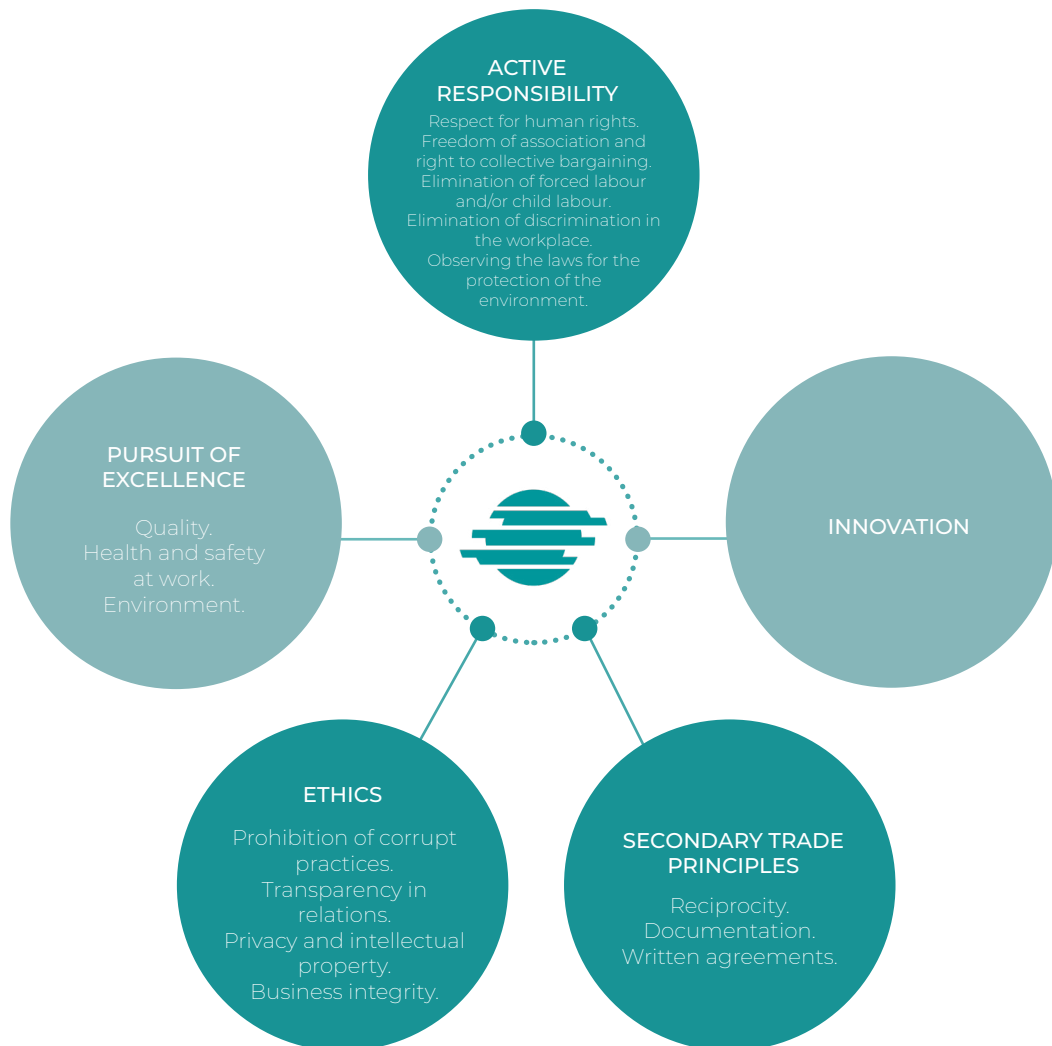

The five pivot areas are based on principles of active responsibility, excellence, innovation, ethics and business, for which OMAL requires full implementation in an active exchange with its suppliers.

As regards the methodology for drafting the Code, it refers to the following initiatives, standards and documents:

• **United Nations Global Compact:**

[www.unglobalcompact.org](http://www.unglobalcompact.org)

• **Universal Declaration of Human Rights:**

<http://www.ohchr.org/EN/UDHR/Pages/Language.aspx?LangID=itn>

• **International Labour Standards (ILO):**

[http://www.ilo.org/rome/risorse-informative/servizio-informazione/pubblicazioni/WCMS\\_151918/lang--it/index.htm](http://www.ilo.org/rome/risorse-informative/servizio-informazione/pubblicazioni/WCMS_151918/lang--it/index.htm)

• **OMAL Code of Ethics “Ethics in OMAL”:**

<http://www.omal.it/Qualita-e-responsabilita/AZIENDA/Politica-sociale>



Here are some indicators on 2019 purchases:

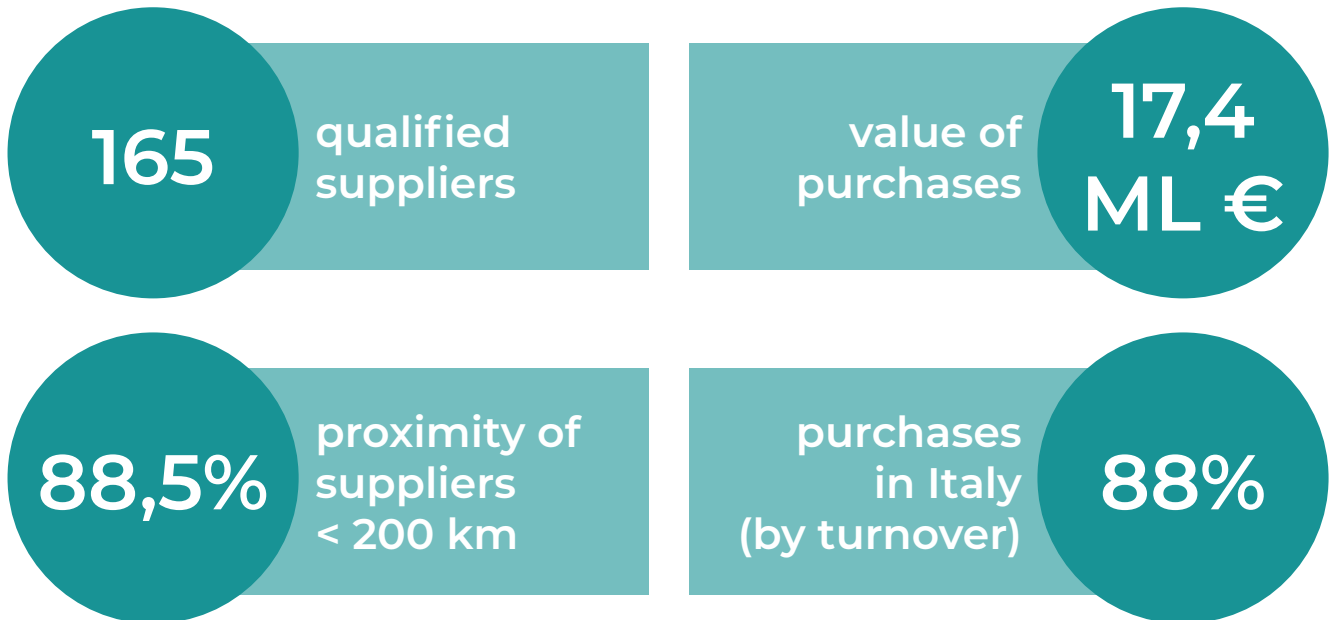

There are 165 qualified suppliers divided into the following types of supply:

### Qualified suppliers by type of supply

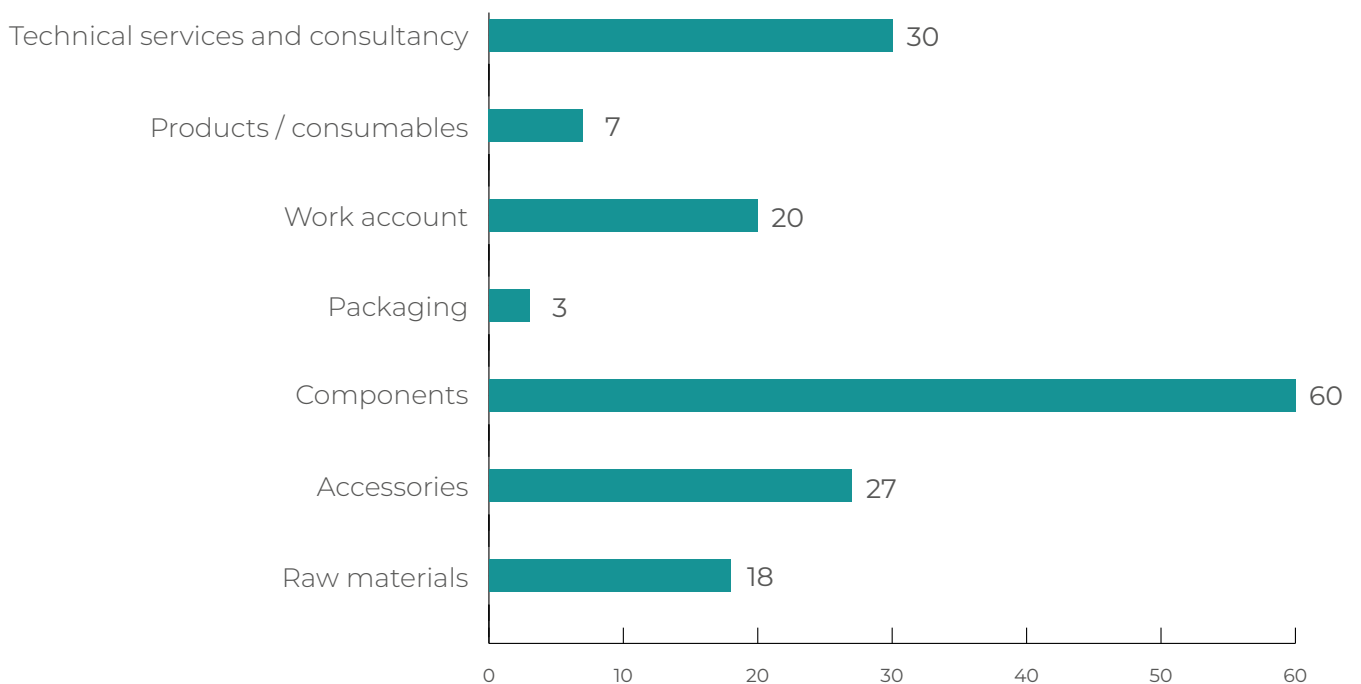

The geographical location of the suppliers and their proximity to the OMAL production plants are an important criterion of choice, with significant repercussions also from an environmental and supply logistics point of view.

Purchases are broken down geographically as follows:

Geographical breakdown of the value of 2019 purchases

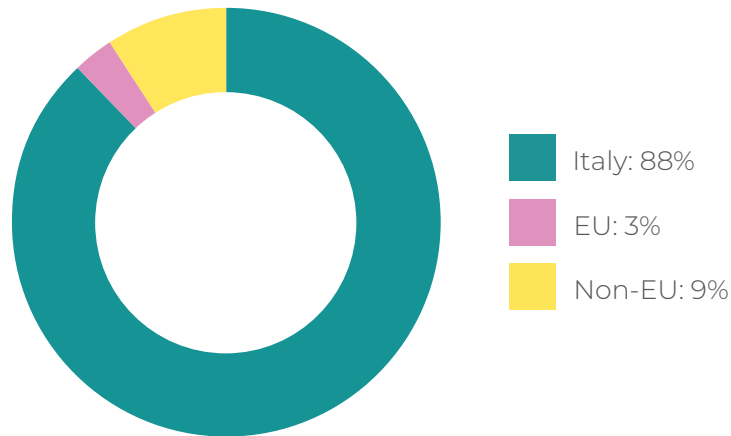

The graph above clearly shows that preference is given to supplies from Italian suppliers and proximity of purchases.

Compared to last year, supplies from non-EU suppliers (-6%) significantly decreased in favour of Italian (+4%) and EU (+2%) suppliers.

Incidence of purchase value by geographical area	2018	2019
Italy	84%	88%
EU	1%	3%
Non-EU	15%	9%
<b>Total</b>	<b>100%</b>	<b>100%</b>

Of the 88% of the value of purchases in Italy, 95.4% comes from Lombardy, where the province of Brescia weighs 70%.

Purchase composition Italy

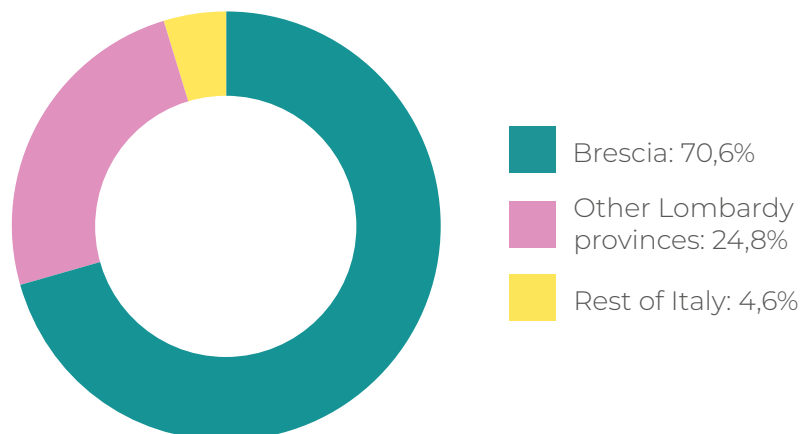

## 4.7 SUSTAINABLE SUPPLY CHAIN

**W**e believe that our suppliers are important partners for building responsible and sustainable practices, for this reason we have adopted a Sustainable Purchasing Policy with which we intend to:

- 1 **Implement procurement practices** in accordance with our values, with the principles of the Code of Ethics and the Supplier Code of Conduct adopted by OMAL, as well as according to the United Nations Global Compact;
- 2 **Select business partners and organisations that share our values** and our sensitivity to environmental and social sustainability, that adopt initiatives aimed at preventing pollution and/or respecting the environment, that have implemented an environmental management system or have the intention to do so;
- 3 **Support suppliers in adopting the most virtuous practices**, so as to minimise environmental and social impacts along the supply chain;
- 4 **Monitor the sustainability of the supply chain** in particular in critical procurement processes;
- 5 **Include requirements linked to sustainability principles in contractual documents** and share them with the supply chain.

The adoption of supplier selection criteria based also on compliance with corporate environmental policies and objectives represents a reduction of the overall risk for OMAL.



47.9% of suppliers have an Environmental Management System certified according to ISO 14001 and/or have implemented ad hoc internal procedures to verify environmental aspects.

78% of our suppliers have read our Code of Ethics and the Supply Code defined by OMAL.

# FOCUS: CANTEEN

In October, OMAL initiated a collaboration relationship with CIRFOOD for the company canteen service, in order to share and implement together new strategies and initiatives aimed at preserving the health of staff, promoting proper nutrition, and ensuring the sustainability of the service.

New menu	Booking via APP	Supply chain sustainability	Recyclable / compostable materials
----------	-----------------	-----------------------------	------------------------------------

The main choices and initiatives for 2019 are summarised below.

**SCOPRI LA NUOVA MENSA** **OMAL AUTOMATION** EMPOWERED PERFORMANCE

Da Lunedì 14 Ottobre 2019 sarà attivo il nuovo servizio di mensa con numerose novità:

- NUOVO PARTNER** CIRFOOD: Certificato in ambito ambientale, energetico, sostenibilità e legalità.
- NUOVO MENU**
- PRODOTTI ECOSOSTENIBILI**: BIO, DOP, IGP, MSC, Km0 e prodotti freschi come formaggi e ortofrutta.
- PRIMI PIATTI**: 3 scelte diverse alternative.
- SECONDI PIATTI**: 3 scelte da menu alternativi.
- CONTORNI**: 2 scelte.
- PANE**: comune e integrale, crostini, cracker.
- FRUTTA**: di stagione, sempre biologica.
- FREE BEVERAGE**
- PIATTI VEGETARIANI**: All'interno del menu saranno sempre presenti piatti vegetariani.
- VASSOIO ECOSAFE**: igienicamente trattato, libero al contatto alimentare, realizzato con materiali 100% riciclabili.
- APP PRENOTAZIONE**: Preordinazione piatti tramite APP scaricabile gratuitamente su smartphone.

TANTE ALTRE NOVITÀ IN ARRIVO!

Per tutti informazioni su sana alimentazione, salute e benessere

**NEWS MENSA** **OMAL AUTOMATION** EMPOWERED PERFORMANCE

**L'ACQUA È UN BENE PREZIOSO**

Da Lunedì 24 Febbraio, ritira in mensa la tua borraccia OMAL/ACTUATECH.

Durante la pausa pranzo potrai riempirla dai distributori in mensa e portarla con te sul posto di lavoro. Eviterai così gli sprechi e ridurrai il consumo di plastica delle bottigliette.

**L'AMBIENTE TI RINGRAZIA**

Required criterion	Proof
Supplier sustainability	Possession of quality, environmental, safety and energy certifications.
Security of supplies	Possession of certification of the traceability of agri-food chains.
Ingredient sustainability	Use of Organic, PDO, PGI, MSC and Local products (fresh products such as cheeses, fruit and vegetables, ...).
Sustainable products used for cleaning	Ecolabel cleaning products.
Plastic free materials	The <b>EcoSafe</b> tray is eco-friendly, entirely made of 100% recyclable materials, it eliminates the placemat, is suitable for food contact and is hygienically treated. The <b>free beverage</b> dispensing system allows staff to serve water and self-service bulk drinks and eliminate packaging.
Proper nutrition	<b>Daily vegetarian menu. Meal booking app</b> provides nutritional information and the energy value of the dishes booked on your smartphone. <b>Tabletop food pyramids</b> provide guidelines for a balanced diet.

## 4.8 CUSTOMER SATISFACTION

Customer satisfaction is our most important objective and a useful indicator for monitoring the effectiveness of the actions taken and the policies implemented.

The sales office is in constant contact with customers and collects ideas and observations, but in order to assess the quality perceived by the customer in more detail, some specific indicators have been created:



Lead time: delivery times expressed in days;



On-time deliveries: percentage of deliveries on time;



Delay days: average number of days of delay;

Analysing the performance of the three indicators used in the table below, it can be concluded that the average delivery time was reduced by 21.1% and only in 11.2% of cases was there a delay in the expected time, which on average was 3.4 days.

Indicator	2018	2019	Change
Lead time	19	15	-21,1%
Percentage of deliveries on time	70%	88,8%	26,9%
Average days of delay	4,17	3,4	-18,5%

Where only 2.5% of deliveries had a delay of more than 5 days.

Performance of deliveries	Percentage
On time	88,8%
Delay 1 - 3 days	7%
Delay 3 - 5 days	1,7%
Delay > 5 days	2,5%
<b>Total</b>	<b>100%</b>



Another important indicator is the ISC - customer satisfaction index which is calculated on the entire portfolio of active customers and on the basis of the following criteria:

- A.** If at least 90% of customers with orders worth more than €10,000 a year have ordered for at least 2 consecutive years, the score assigned is equal to 100 otherwise it is equal to the ratio between the two years;
- B.** If the turnover is higher than that of the previous year, the score assigned is equal to 100, otherwise the ratio between the current year's turnover and the previous year's turnover;
- C.** If the Customer Return Value does not exceed 1% of the turnover, the score assigned is equal to 100 otherwise it is equal to (100 - ratio between the two);
- D.** The value of the on-time delivery index is given by the ratio between the number of deliveries made with no more than 3 days of delay and the number of total deliveries.

Furthermore, a distribution coefficient is assigned to each criterion according to the importance and sensitivity of the criterion and the data collected by the management system.

The resulting algorithm is  $ISC = (A * 0.3) + (B * 0.3) + (C * 0.2) + (D * 0.2)$



As can be seen from the graph, for 2019 the ISC was not only higher than the minimum value set by OMAL as a target of 90, but also better than last year.

ISC trend customer satisfaction index

ISC Minimum target

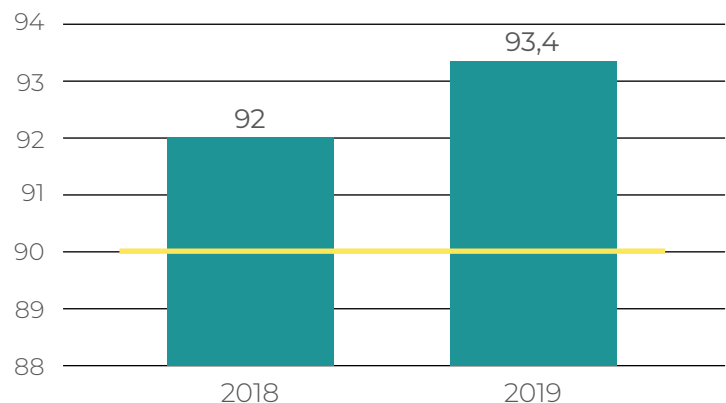

## 4. QUALITY

Another important indicator for evaluating customer satisfaction is the value of returns due to disputes over the turnover value.

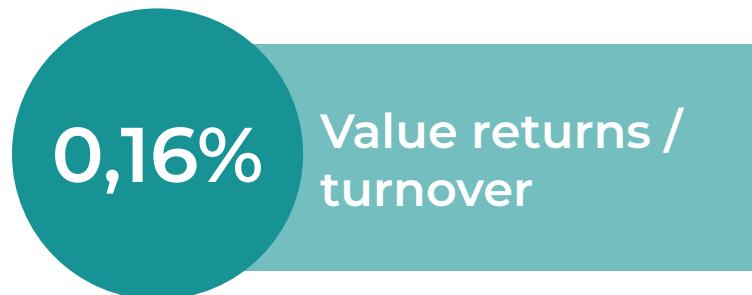

The index for 2019 is 0.16%, well below the minimum target of 1%.

The trend in production waste is below the minimum target of 1% and further improved compared to last year.

### Processing waste trend

■ Waste ■ KPI

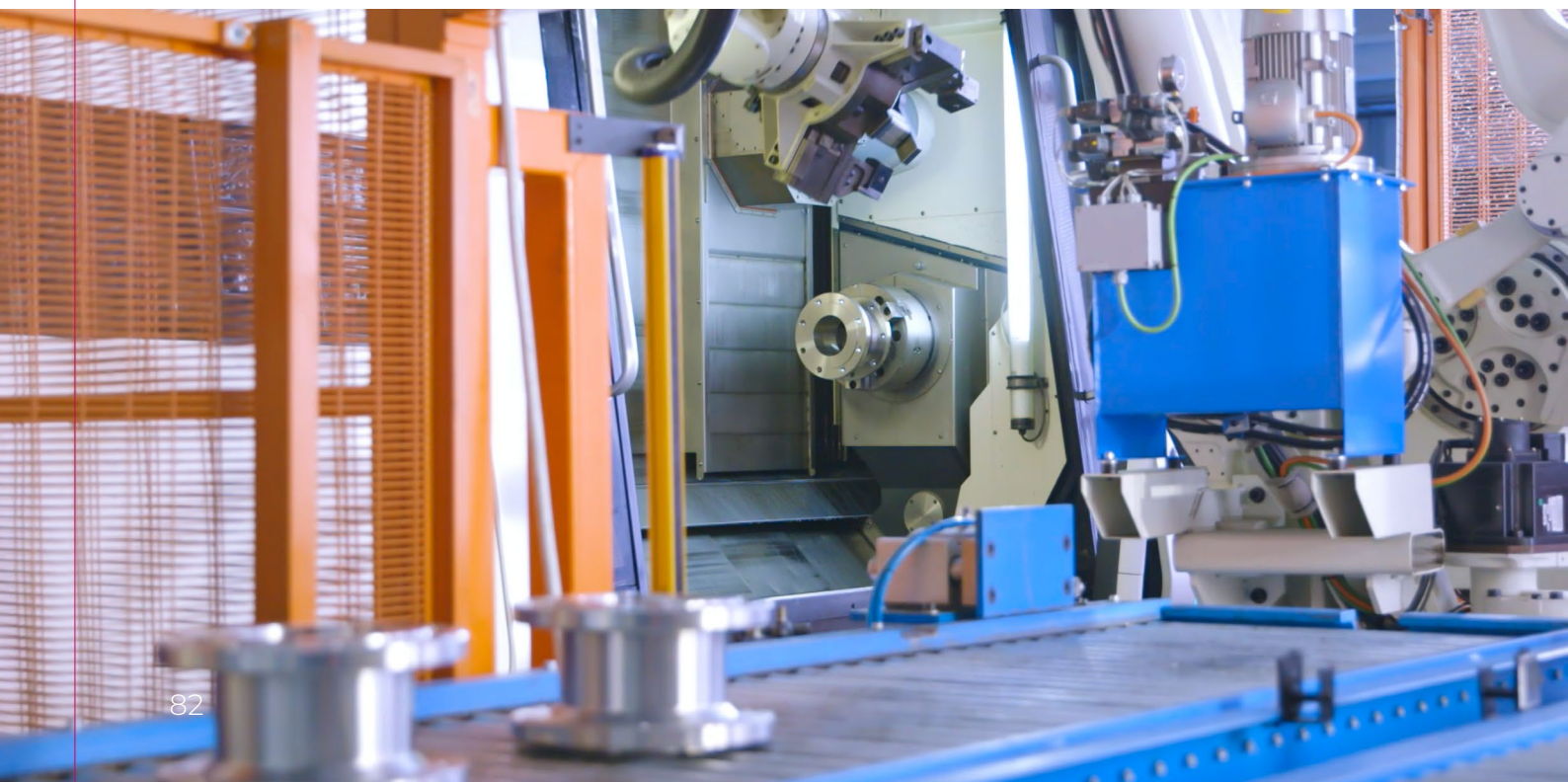
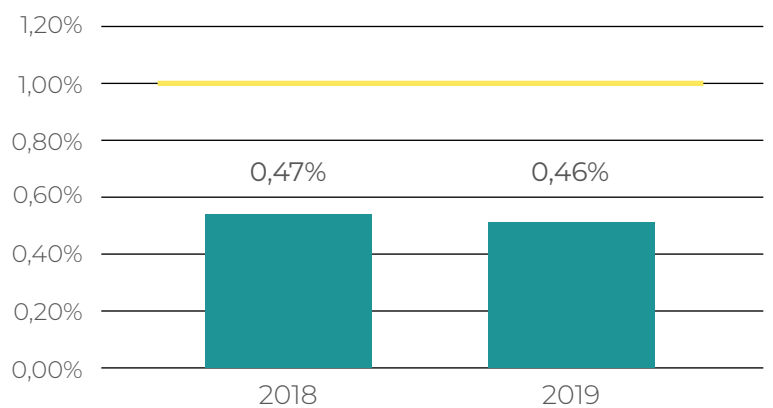

# FOCUS: PERFORMANCE COMPARED TO KPIs SET

Summarising the performance indicators with respect to the KPIs set, we can conclude that in 2019 we recorded a very positive overall performance, always within the set targets.

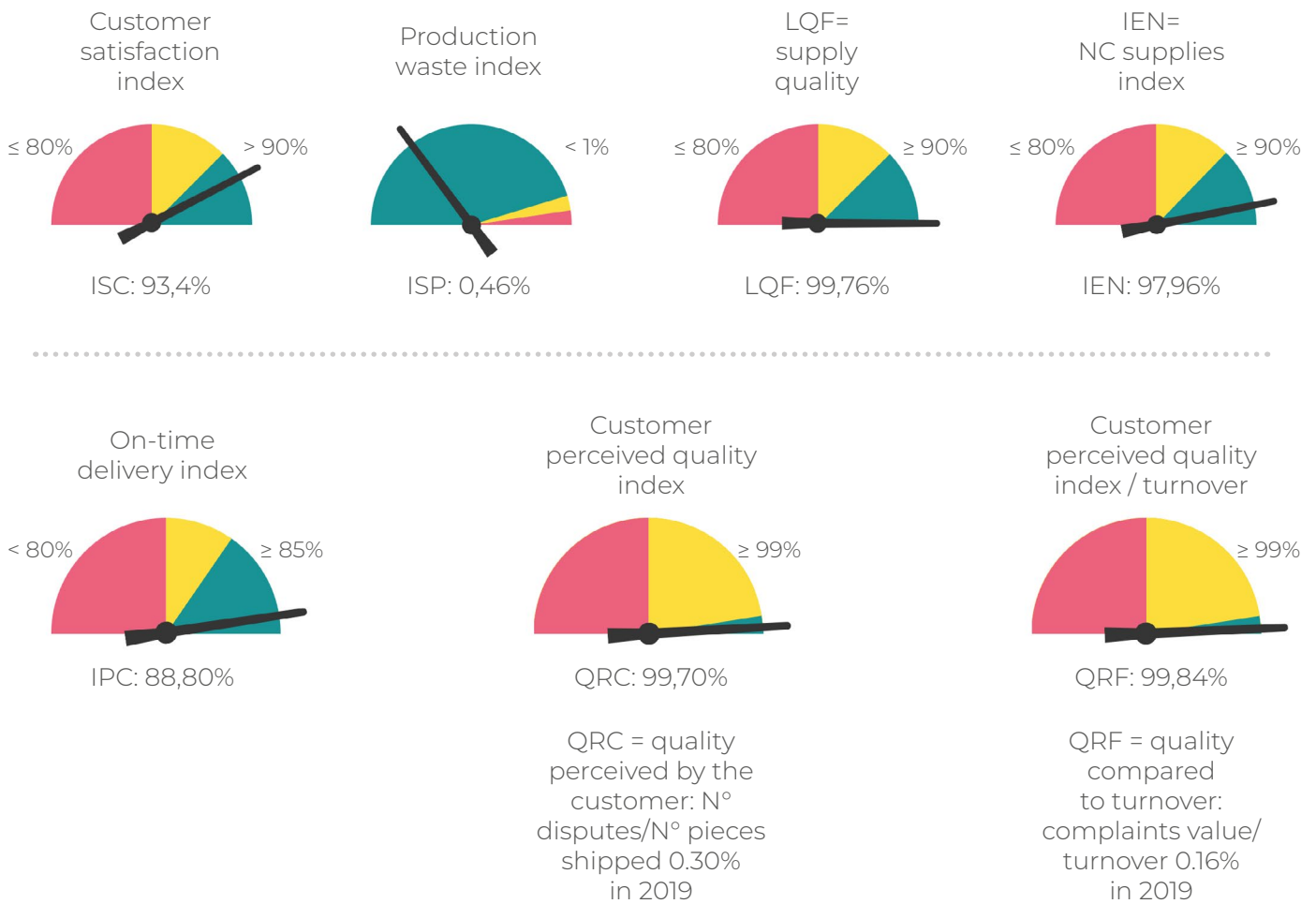





ENVIRONMENT

5

# ENVIRONMENTAL COMMITMENT FOR FUTURE GENERATIONS

## Material issues

Green supply chain	Efficient resource management	Waste management and circular economy	Reduction of GHGs and environmental impacts
--------------------	-------------------------------	---------------------------------------	---

We are committed to improving our performance, reducing waste, producing increasingly durable valves and actuators to ensure that future generations have the same access to natural resources as we have.

PROCUREMENT OF ENERGY FROM RENEWABLE SOURCES	SELF-PRODUCED RENEWABLE ENERGY	HEAT RECOVERY FROM COMPRESSORS
<b>100%</b>	<b>112.805 kWh</b>	<b>7.268 kWh</b>
CIRCULAR RECOVERY	% OF WASTE IN LANDFILL	WATER RECOVERED AND REUSED
<b>94,9%</b>	<b>0,6%</b>	<b>30.000 LITRES</b>

## Reference Goal - GRI (Global Reporting Initiative)

<b>6</b> CLEAN WATER AND SANITATION 	<b>7</b> AFFORDABLE AND CLEAN ENERGY 	<b>9</b> INDUSTRY, INNOVATION AND INFRASTRUCTURE 	<b>12</b> RESPONSIBLE CONSUMPTION AND PRODUCTION 	<b>13</b> CLIMATE ACTION 
--	---	---	---	---

# 5.1 RESPECT FOR THE ENVIRONMENT

For OMAL, the protection and commitment to the environment and the territory represent an intrinsic value in the way we do business, a continuous drive for improvement and innovation and a value that we want to spread more and more in the individual Units.

The commitment to protecting the environment is promoted and encouraged by the Management and extended to the entire organisational context, shifting daily actions towards:

- sustainable use of resources;
- the optimisation of procurement processes;
- the reduction of waste production;
- the recovery and/or recycling of materials with a view to circular economy;
- sharing our Policies with the supply chain;

In addition, we seek to improve internal and external communication to promote a culture of work oriented towards sustainability through annual reporting and ad hoc social media campaigns.



The relationship with the environment therefore shifts from corporate boundaries to relationships with customers and suppliers, considering “extended management models” capable of reducing overall impacts through the involvement of all actors in the chain, creating sustainable value for stakeholders and minimising inefficiencies and risks.

## 5.2 AWARDS FOR OUR COMMITMENT TO THE ENVIRONMENT

### CSR RATING ECOVADIS

OMAL's commitment to the environment has been recognised by ECOVADIS, one of the leading international sustainability rating platforms, with a **Gold sustainability performance level**.



The score achieved in the “production of machines for general use” category places OMAL's environmental performance in the ranking of companies evaluated according to the Policies adopted, the actions implemented and the results achieved. At the beginning of this year OMAL updated its rating and is waiting for the new 2020 certificate.



## B CORP AWARD: “BEST FOR THE WORLD 2019”

In 2019 OMAL was also awarded for its commitment to the environment. In the Benefit Impact Assessment OMAL scored, in the ENVIRONMENT section, over **10 percentage points above**

**the world average for B Corps.**

This important recognition for commitment to the environment was given to only 11 Italian companies belonging to various sectors. If, on the other hand, we look at its specific product category (**Industry section**), OMAL is **the only one to qualify worldwide.**



## 5.3 THE MANAGEMENT SYSTEM AND ENVIRONMENTAL POLICY

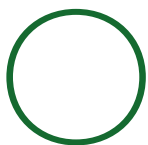

MAL has voluntarily adopted an Environmental Management System compliant with the ISO 14001:2015 standard which allows it to monitor and control environmental impacts, correctly assess risks and guarantee its legislative compliance.

In everyday life, this is reflected in lines of action, policies and operating procedures that allow for the coordinated and systematic management of all activities and processes that may have repercussions on the environment.

Our Environmental Policy guides our actions and sets improvement targets regarding:

- reduction of resource consumption through technological innovation and the adoption of higher performing technical and organisational solutions;
- pollution risk prevention through constant monitoring of the environmental impacts of our production sites and along the supply chain;
- minimisation of waste production by favouring recovery-recycling and reuse according to the principles of circular economy;
- definition of the characteristics and performance of products that ensure control of the impact on the environment during operation and when the end of life is reached;
- improvement of communication inside and outside the organisation to promote a work culture oriented towards sustainability.

## 5. ENVIRONMENT

The system concerns all activities carried out at the Rodengo Saiano and Passirano plants. Specifically, the design and production of pneumatic and electric actuators, coaxial and flow-started pneumatic valves, manual and automated ball and butterfly valves through mechanical processing, plastic moulding, assembly, testing, packaging and shipping processes.

With a view to continuous improvement, each year specific environmental targets and sustainability objectives are defined which are then implemented in all business units.

The Quality Manager supervises the correct application of the system, collects the information needed to update the defined performance indicators, verifies regulatory compliance, coordinates audit activities and manages relations with the Certification Body.

During the DNV surveillance audit, one observation and two opportunities for improvement emerged which the Quality Manager took on board and resolved.



## 5.4 GREEN IN

Care for the environment has led OMAL to analyse the entire value chain and assess specific optimisation actions of the various processes. The GREEN IN project was born with the aim of improving the impacts related to the supply chain and procurement.

The focus therefore shifts from OMAL as a company to the system of relationships and actors upstream of our production process.

## SUSTAINABLE SUPPLY CHAIN

By sustainable procurement we mean:

- strict selection of suppliers on the basis of environmental and social criteria and sharing our values (Code of Ethics) and policies (Supplier Code of Conduct) with them;
- involvement of the main suppliers in projects to optimise the resources used and the circular economy;
- reduction of the impacts related to procurement logistics;

As regards the first point, we refer to the previous chapter where we analysed our sustainable supply chain in detail (paragraph 4.7).

The main actions implemented to engage suppliers in circular economy projects concerned the aluminium and brass supply chain in particular, through:

- modification of the length of the purchased aluminium profiles to optimise cutting phases and reduce processing waste;
- transfer of metal waste from OMAL's processes to suppliers of raw materials to create a virtuous circuit with a view to circular economy;
- redefinition of the aluminium supply chain relations thanks to the subsidiary Actuatech to which the aluminium waste is delivered, transformed into alloy ingots that it reuses in the die-casting process necessary for the production of semi-finished products purchased by OMAL.

OMAL has started a process to extend this mechanism to all its subcontractors, implementing a framework agreement with them, in which they are asked to return the mechanical processing waste to the same suppliers from which they purchase the raw material.

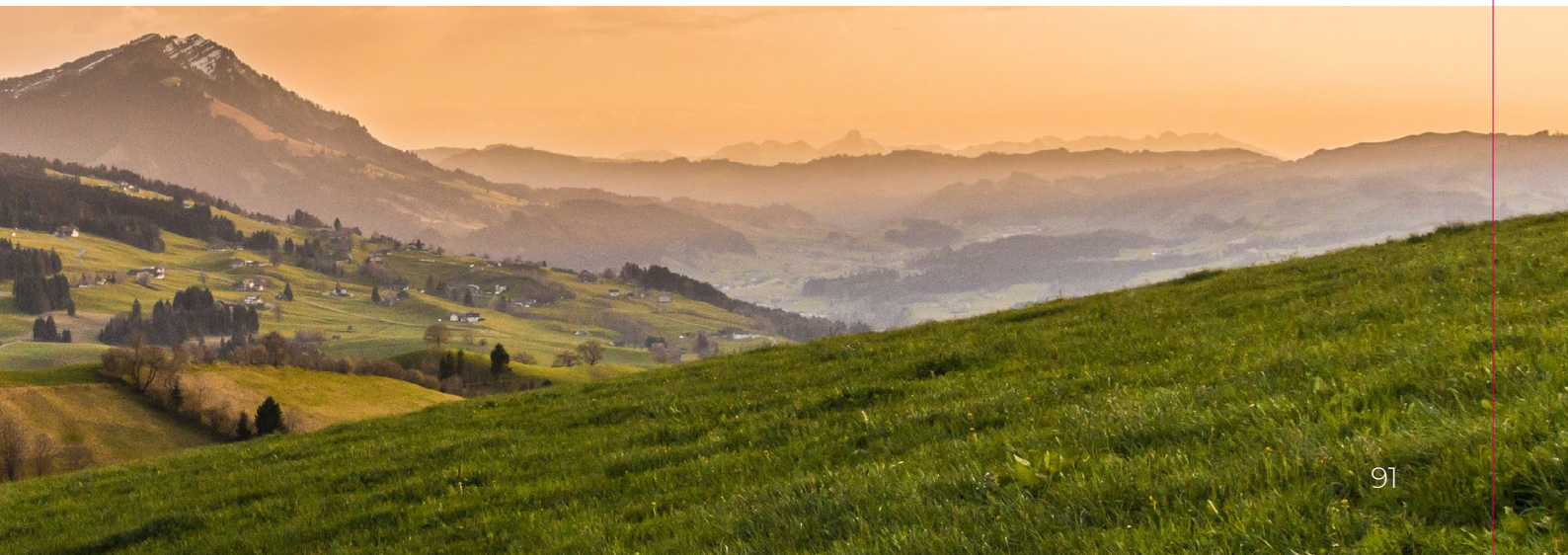

## SUSTAINABLE PROCUREMENT

As seen in the previous chapter, 88% of the value of purchases comes from Italy.

The choice to give preference to national suppliers is motivated not only by the quality of the materials, but also by the proximity and speed of supplies.

Analysing the average distance of the 165 qualified suppliers, 88% are less than 200 km away from OMAL.

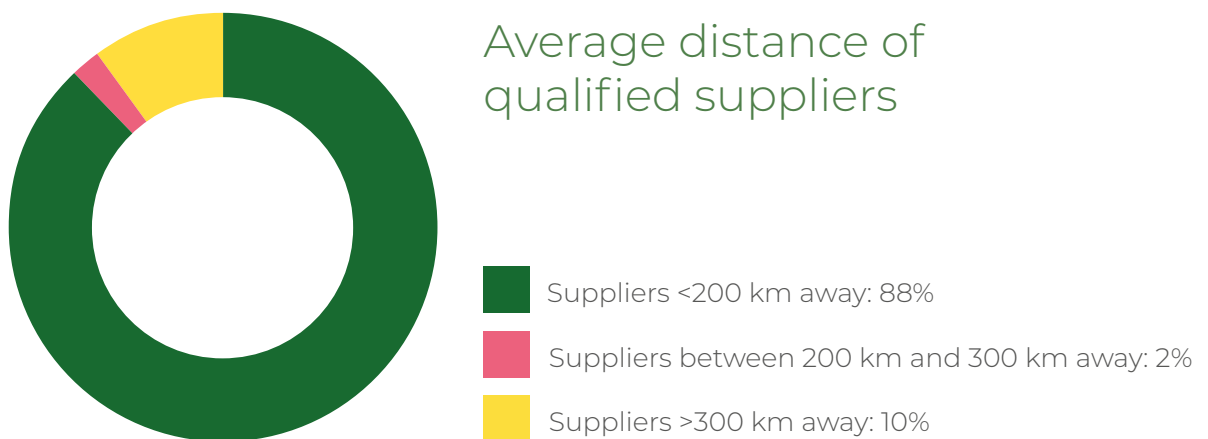

## INCOMING LOGISTICS OFFSETTING

For some years OMAL has been part of several projects to offset CO2 emissions related to the logistics of its procurement. The three main logistics partners: Aprile Spa, Shenker Italia Spa and DHL Express, which manage about 90% of the incoming movements, quantify and report the impacts generated by the transport carried out for OMAL and offer the possibility to offset them by joining specific projects.



With the acquisition of these credits OMAL finances various types of projects such as reforestation or planting, the production of energy from renewable sources or biomass, the recovery of polluted or socially disadvantaged areas. The quantity of certificates purchased corresponds to the number of tons of CO<sub>2</sub> generated by the transport carried out on behalf of OMAL:



## 5.5 GREEN US

This section analyses all the activities to reduce environmental impacts implemented directly on the company's internal processes in depth.

### ENERGY

Correct energy management has always been a central theme for OMAL and investments in recent years have been directed towards:

- building efficiency;
- efficiency of plants and consumption monitoring;
- self-production of energy;
- purchase of clean energy;

#### BUILDING EFFICIENCY

Our factories are built according to high performance standards that allow us to reduce energy consumption. In particular, the Passirano site is equipped with an **insulation system** that includes a shed roof and polycarbonate windows and reinforced concrete tiles with insulation. The external façades of the shed are made with prefabricated panels that allow us to **reduce noise emissions and reduce heat lost to the outside by 20%**.

## PLANT EFFICIENCY AND CONSUMPTION MONITORING

At the plant level, investments have been made in:

- **automation systems** to centrally manage and optimise the operating periods of the summer and winter air conditioning system in order to reduce consumption;
- The heating of the building is also guaranteed by the **recovery of the heat produced by the compressors** during their normal operation. Assuming an average use of 16 hours/day, the intervention allows us to **reduce energy consumption by 7,268 kWh<sup>1</sup> thus avoiding the emission of 958 kg of CO<sub>2</sub>eq**;
- all systems (compressors, air conditioning, electrical ...) are equipped with **inverters**;
- The main heating and heat recovery circuits are equipped with **thermal energy counters to control and monitor consumption**;
- energy consumption management is monitored by the MOVICON Pro Energy application, which, from the end of 2019 onwards, makes it possible to check and optimise consumption and prevent waste and inefficiencies.

<sup>1</sup> Calculation carried out assuming that the recovered heat is produced by the air conditioning system installed at the Passirano (BS) site.

## ENERGY SELF-PRODUCTION

As far as self-production of electricity is concerned, OMAL has installed a photovoltaic system consisting of 400 panels capable of providing a minimum contribution of 100,000 kwh/year of renewable energy.

In 2019, 112,805 kwh of energy was produced, of which 93.3% used for self-consumption and 6.7% sold to the national energy grid.

The energy used for our own activities and produced by the photovoltaic system has made it possible to avoid not only CO<sub>2</sub>eq emissions linked to the production of this energy, but also grid losses linked to its feeding into the national grid.

The graphs below show the performance of the system from 2017, the year of installation, to date:

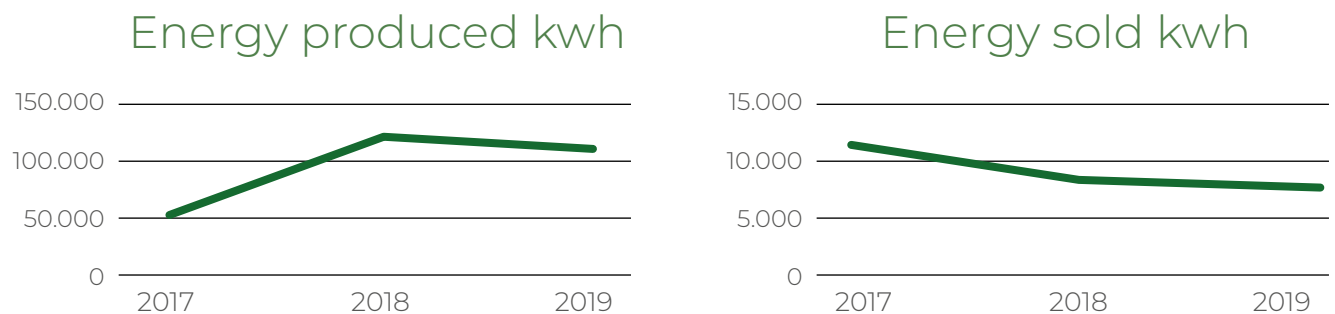

The energy produced and sold decreased slightly compared to the previous year due to a variation in the levels of solar radiation during the year and to a physiological decline in the efficiency of the plant. During 2020, the possibility of cleaning the panels will be evaluated to restore the system to maximum efficiency.

Photovoltaic system performance	2018	2019	Change %
Energy produced in Kwh	118.122	112.805	-5%
Energy sold in Kwh	8.566	7.592	-11%

## PURCHASE OF CLEAN ENERGY

After having made our plants more efficient, recovered heat, streamlined consumption and self-produced energy, the remaining energy requirements are met by a contract for the purchase of energy certified by A2A as coming 100% from renewable sources.

Below is the certification of origin and the certificates issued by A2A to guarantee the origin of the electricity purchased by OMAL in 2019.



[www.a2aenergia.eu](http://www.a2aenergia.eu)



This choice allowed OMAL to save about 765 tons of CO<sub>2</sub> equivalent. This was calculated based on the total kWh used by OMAL, compared with the impact that would have been generated by using the average national energy mix, compared to the virtuous choice of using self-produced energy from the photovoltaic system and the specific clean energy applied by A2A.

-77,5%  
CO<sub>2</sub>eq.

Impact avoided by using green energy  
+ consumption of energy self-produced  
by the photovoltaic system.

	2017	2018	2019
EECS certificates issued and GO certificates	705	1712(*)	1744(*)

(\*) The "GO guarantee of origin" is the document referred to in Article 15 of Directive 2009/28/EC aimed at proving to end customers the share or quantity of energy from renewable sources in the energy mix of an energy supplier.

## ENERGY CONSUMPTION

Energy consumption can be traced back to production machinery, heating and air conditioning and fuel for the company's mobility of vehicles and forklifts. The trend in energy, methane and gas consumption over the last three years can be summarised as follows:

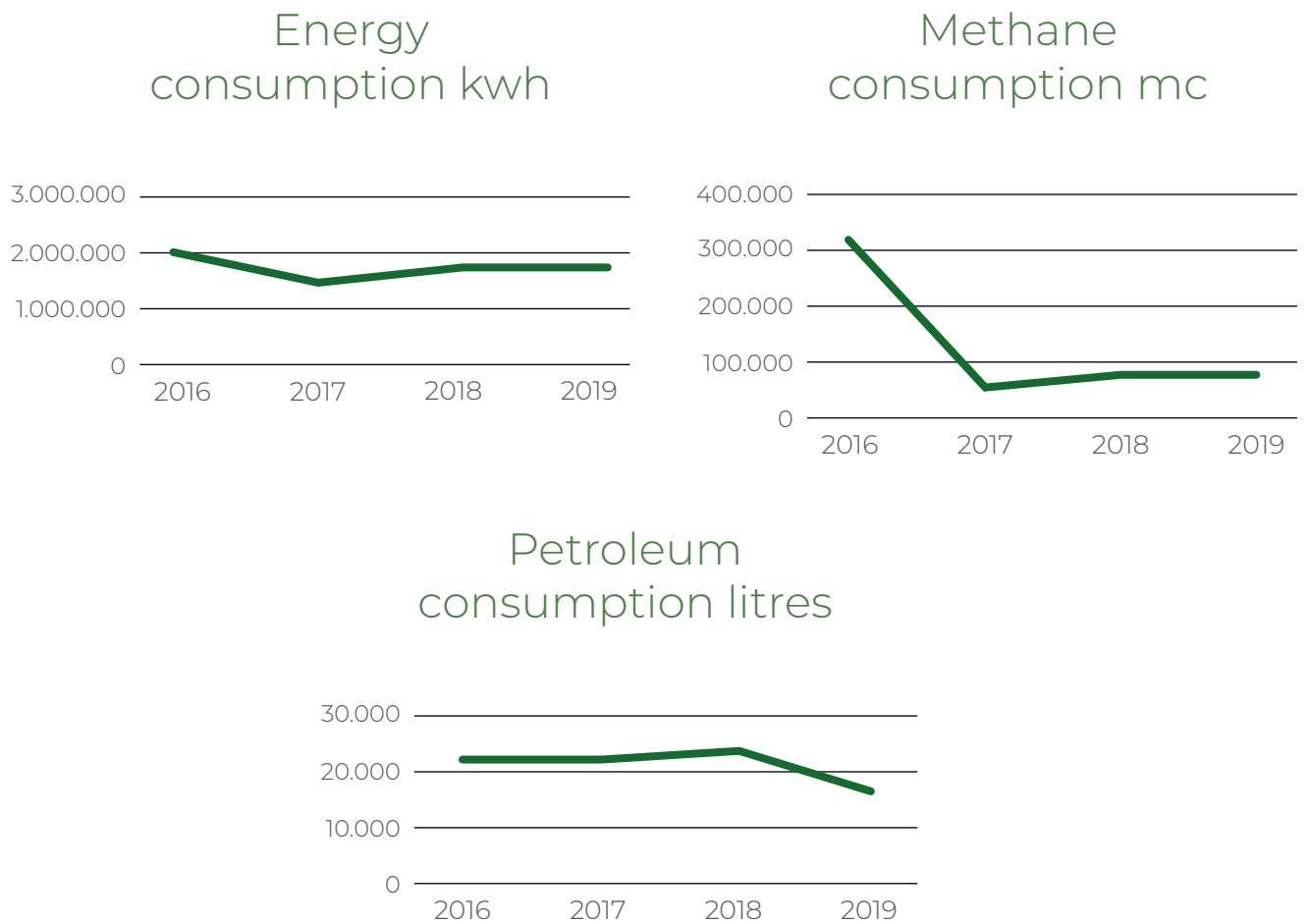

Electricity consumption has slightly increased compared to last year due to the decision to bring some production processes in-house (e.g. station for aluminium cutting and sandblasting) which were previously entrusted to subcontractors and which did not involve consumption by OMAL.

Electricity consumption	2018 (values in Kwh)	2019 (values in Kwh)	Change %
Electricity purchased	1.713.887	1.744.476	1,8%
Electricity self-produced and consumed	109.556	105.213	-4,0%
<b>Total electricity consumption</b>	<b>1.823.443</b>	<b>1.849.689</b>	<b>1,4%</b>



By comparing electricity consumption with the number of hours worked or to the annual turnover, a performance indicator is obtained which, in both cases, is very similar to the previous year.

Energy consumption performance indices	2018	2019
Annual hours worked	174.161	180.445
Electricity consumption / Annual hours worked	10,47	10,25
Electricity consumption / Turnover	0,058	0,060

Considering the trend in consumption from energy sources translated into Gigajoules, there is an overall positive performance compared to last year with a reduction of 3.9%.

TREND OF CONSUMPTION OF ENERGY SOURCES			
Energy source	2018 (values in GJ)	2019 (values in GJ)	Change %
Electricity purchased	6.169,99	6.280,11	1,8%
Electricity self-produced and consumed	394,40	378,77	-4,0%
Methane	2.695,53	2.492,48	-7,5%
Diesel	868,91	585,04	-32,7%
<b>Total consumption</b>	<b>10.128,83</b>	<b>9.736,40</b>	<b>-3,9%</b>

By comparing the annual energy consumption with the turnover and the hours worked, a better performance is also obtained compared to 2018.

Energy consumption performance indices	2018	2019
Consumption / Annual turnover	0,00032	0,00031
Consumption / Annual hours worked	0,058	0,054

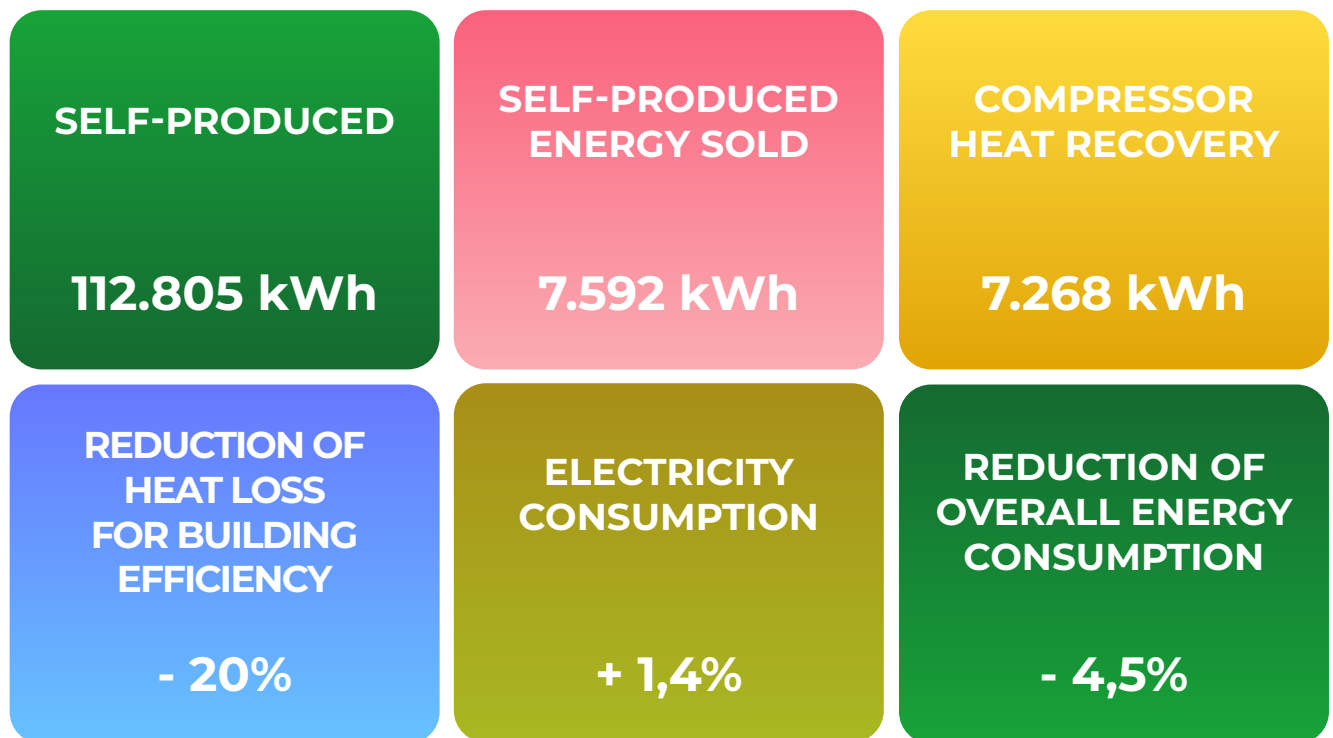

## WATER

Water consumption mainly concerns civil uses and the irrigation of the green spaces surrounding the two plants, while production activities do not require particular process water consumption.

During 2019, the project for the recovery and reuse of condensation water generated by the compressed air plant at the Passirano site was completed.

The system makes it possible to separate the water from the condensate oil and to break down the bacterial load with specific substances and subjecting it to UV rays. Every year the plant can purify and reuse as much as 30,000 litres of water in the production process.



In addition to water recovery, this system makes it possible to purify the wastewater leaving the compressed air system which may contain variable quantities of oil and particularly polluting impurities.

### Water consumption mc

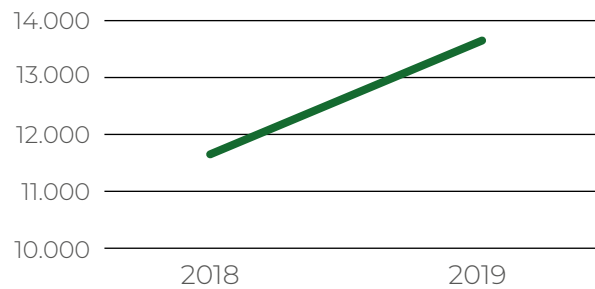

The total annual water consumption has increased abnormally, but analysing the performance of each plant it can be seen that while the Passirano plant recorded a reduction in water supply of -39%, the Rodengo Saiano site deteriorated sharply due to a leak in the greenery irrigation system.

Water consumption in mc	2018	2019	Change %
Passirano site	5.986	3.660	-39%
Rodengo Saiano site	5.644	9.975	77%
<b>Total</b>	<b>11.630</b>	<b>13.635</b>	<b>17%</b>

Since water resources are not a critical factor for the production process, consumption was not subject to precise control and for this reason the leak was not detected promptly. The goal for the new year will be to periodically monitor water consumption as well.

# FOCUS: PLANT REMEDIATION SYSTEM FOR WASTEWATER

The Passirano site has adopted a plant remediation system for waste water.

Thanks to specific plants capable of absorbing heavy metals such as lead and nickel, OMAL returns chemically and bacterially purified water to the environment. These plants protect the purification system from low winter temperatures, provide a greater spectrum of activity to the bacterial micro fauna and absorb the mineral substances released during the purification process.



# WASTE MANAGEMENT

The objective of sustainable waste management consists of:

- reducing the amount of waste produced and circular economy actions;
- maximising the amount of waste destined for recovery;
- reducing the proportion of hazardous waste out of total waste;
- reducing the proportion of waste going to landfill;

In the belief that great results can also be achieved through small efforts, we have invested in training and raising staff awareness on proper waste separation and sorting methods in order to send as much waste as possible for recovery.

Collection data from the last two years shows that the effort has paid off:

	2018	2019	Change %
Waste produced	535.438	582.321	8,8%
Proportion of hazardous waste out of the total	4,90%	3,60%	-1,30%
Percentage of waste sent for recovery	96,80%	99,40%	2,60%
Percentage of waste sent to landfill	3,20%	0,60%	-2,60%

Although the share of waste produced increased by 8.8%, the quality of waste collected made it possible to landfill only 0.6% compared to 3.2% last year.

Of the 99.4% of waste sent for recovery, 4.5% was in the form of energy recovery and 94.90% was sent for recovery according to the principles of the circular economy to guarantee its reuse in other production processes for the production of new products and incoming materials.

Waste by destination

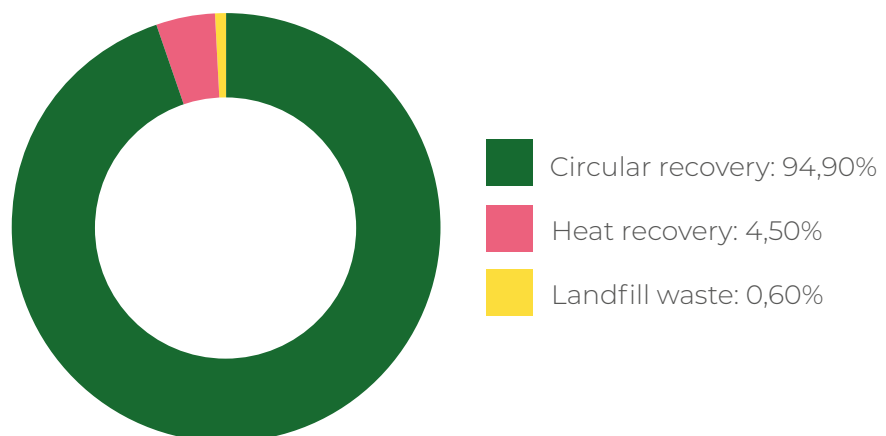

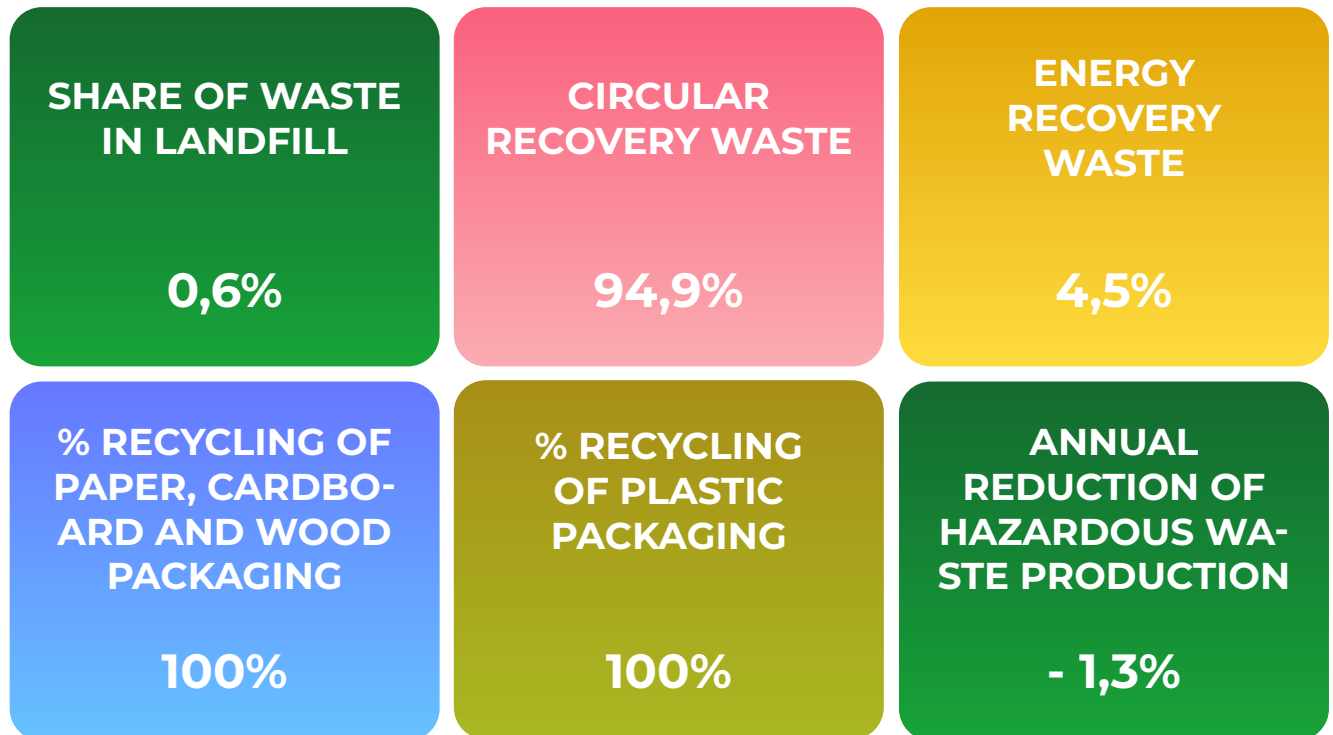

## CARBON FOOTPRINT

OMAL's focus on climate change and GHG emissions from its activities has led it to calculate and certify its *carbon footprint* according to ISO 14064:2012 in 2016. The *carbon footprint* is the quantification of the direct and indirect impacts of activities that fall under the responsibility of the organisation and translated into CO<sub>2</sub> equivalent.

In accordance with the standard and the GHG Protocol, emissions are accounted for in accordance with:

**SCOPE 1: DIRECT EMISSIONS**  
direct GHG emissions from installations within the organisation's perimeter.

**SCOPE 2: INDIRECT EMISSIONS DUE TO ENERGY CONSUMPTION**

indirect GHG emissions from the generation of electricity, heat and steam imported and consumed by the organisation.

**SCOPE 3: OTHER INDIRECT EMISSIONS**

emissions related to the manufacture of products and the provision of the services used by the organisation, such as emissions from production and transport of raw materials, packaging, auxiliary materials, waste treatment, from the distribution of finished products and end-of-life products and their packaging.

After the first study in 2016, it was decided to repeat the calculation every two years on all the activities carried out by the organisation to verify the effects of the policies implemented. In 2018 the full study was therefore repeated as reported in the previous report, while for this year the analysis was limited to scopes 1 and 2.

The results show a general decrease in impacts in terms of CO<sub>2</sub> equivalent (-0.8%), mainly due to an improvement in the consumption featured in scope 1.

Scope	2018 (values in tCO <sub>2</sub> eq)	2019 (values in tCO <sub>2</sub> eq)	Change %
<b>Scope 1: direct emissions</b>	<b>191,01</b>	<b>184,03</b>	<b>-3,7%</b>
Methane combustion	126,83	140,82	11,0%
Diesel consumption	64,17	43,21	-32,7%
Emissions into the atmosphere	0	0	0,0%
<b>Scope 2: indirect emissions</b>	<b>217,94</b>	<b>221,61</b>	<b>1,7%</b>
Electricity consumption	217,94	221,61	1,7%
<b>Total Scope 1 and 2</b>	<b>408,95</b>	<b>405,64</b>	<b>-0,8%</b>

As seen also in the paragraph dedicated to energy, bringing certain processes in-house also had an impact in terms of GHG with + 3.67 tons of CO<sub>2</sub>eq.



## FOCUS: OFFSETTING EMISSIONS

Our attention to the environment and reducing impacts has led us to undertake various offsetting projects to neutralise some of the GHG emissions attributable to our activities.

In particular:

- procurement logistics
- website

CO <sub>2</sub> offset		2016	2017	2018	2019
Green In	ton	351	206	236	210
Website		200	400	400	450
Total		551	606	636	660



## OTHER GREEN US INITIATIVES

### ZERO CO<sub>2</sub> EMISSION WEBSITE

Browsing, sending e-mails, watching videos online consumes electricity, the production of which generates CO<sub>2</sub> emissions. For some years now OMAL has participated in the CO<sub>2</sub>web® project of Rete Clima, which offsets the CO<sub>2</sub> emissions generated by access to the OMAL website according to the number of pages visited per year<sup>2</sup>. The offsetting takes place through reforestation in Italy, in combination with environmental education programmes carried out for free in schools.

<sup>2</sup> Offsetting carried out by Rete Clima® based on the ENEA-MSE document by encoding a specific emission coefficient in terms of CO<sub>2</sub>eq/kWh, based on the national energy mix declared by Terna for 2012.

### PAPER CONSUMPTION

OMAL has always been attentive to paper consumption by launching the Zero Paper Project in 2012. This project was based on a gradual reduction in paper consumption thanks to the digitisation and computerisation of processes, the use of specific software and Apps, as well as the features of the new website. The Smart Factory project permeates the entire company and allows it to manage all documentation digitally:

- all workstations are equipped with networked PCs from which it is possible to digitally manage all the information needed by the operator in production, from technical drawings to control plans, and share an increasing volume of information, through dedicated applications or those connected to the Panthera management system.
- a Project Management system allows coordinated management of activities, from the planning and progress phase to their closure. JPA also manages some critical or strategic “internal processes” by distributing responsibilities and activities (through a specific work-flow).
- The features of the new website and the OMAL Catalogue App allow easy access to product information. The App is a functional tool for the OMAL sales network, available in English and Italian, which allows users to consult the prices of each item, view and download the related 3D, and make a sort of personal order cart that can be sent to the OMAL back-office.

The organisation’s digital evolution has also made it possible to increasingly reduce the amount of paper printing, always favouring the management and sharing of documents and copies in electronic format and their storage in digital archives.

### USE OF RECYCLED AND/OR FSC CERTIFIED STATIONERY AND PAPER

Green procurement also translates into the decision to use sustainable gadgets: all pens, pencils, bags and canvas bags bearing the OMAL brand are made from recycled material. All catalogues, brochures and communication materials are printed on recycled or FSC certified paper. The “Zero Paper” project, which has been underway for some years now, has made it possible to minimise paper consumption but, where it is impossible to do without it, only FSC and ECOLABEL certified paper is used to guarantee that the raw material used comes from forests where strict environmental, social and economic standards are met.

### SUSTAINABLE PACKAGING

The boxes and spacers of the multi-packs of OMAL products are made of corrugated cardboard marked “Fully made with recycled paper” which guarantees that the raw material used for the paper and cardboard is recycled and recyclable by the Paper Mills Association.

The outer packaging, having to guarantee greater resistance and protection, are instead produced in

corrugated cardboard containing only a lower percentage of recycled material, but it is still guaranteed to be completely recyclable at the end of its life in the COMIECO circuit.

### IoBevo PROJECT

The “IoBevo” (“I Drink”) project, launched a couple of years ago, means that drink dispensers are available in the canteen to replace disposable bottles and cans. On an average of 5,000 meals a year, the benefits can be quantified as follows:

- 180 kg less waste generated;
- 7,6 tonnes of goods (bottles/cans) not transported;
- 240 kg of diesel saved due to non-transportation of goods;
- 280 kg of CO<sub>2</sub> not released into the atmosphere in relation to the plastic bottles not produced;

## FOCUS: ENVIRONMENTAL PERFORMANCE COMPARED TO KPIS SET

Summarising the results of our environmental performance against the KPIs set, we can conclude that we performed well in 2019.

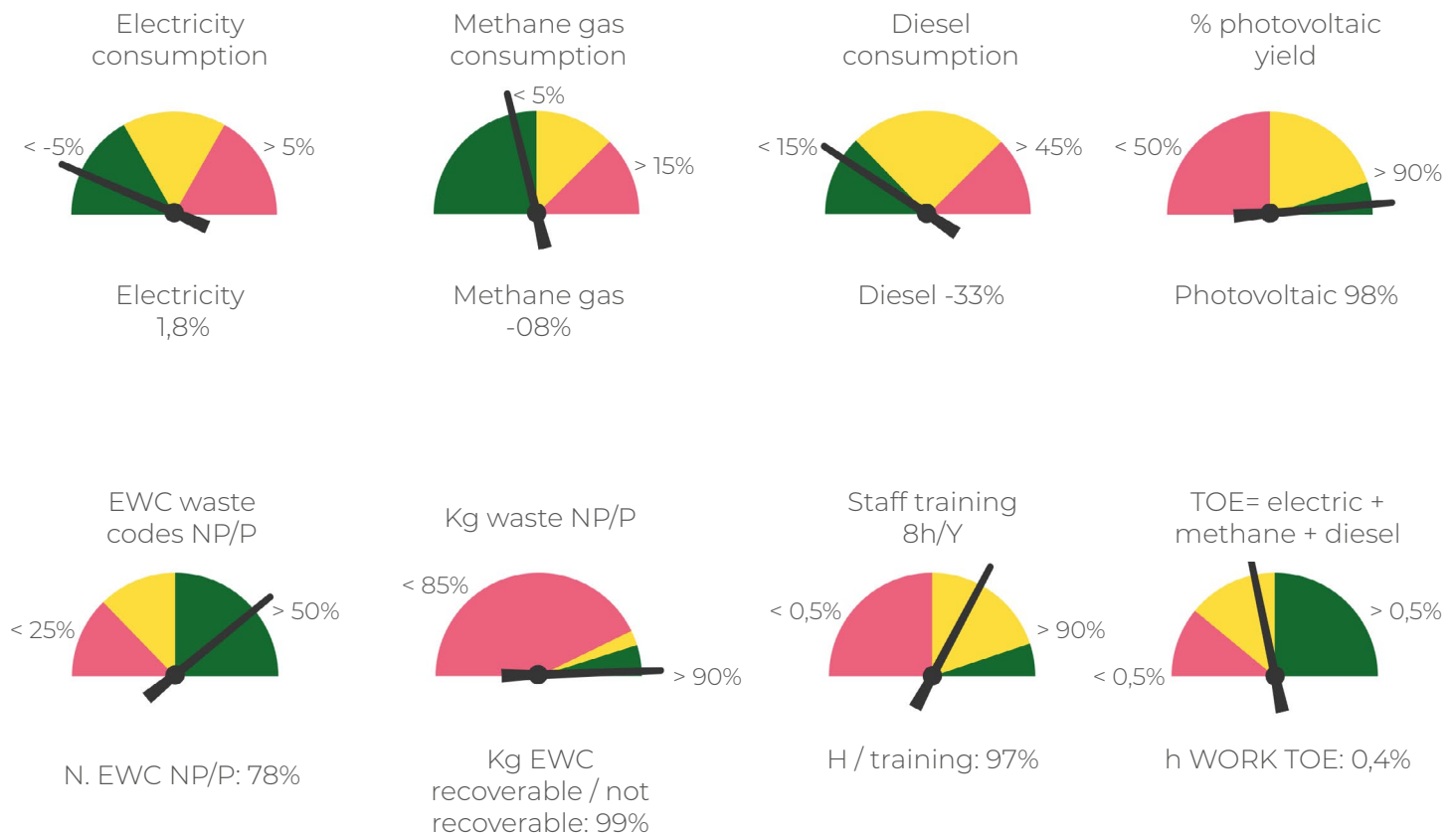



# 5.6 SUSTAINABILITY OF OMAL PRODUCTS

**O**MAL products are designed and manufactured to ensure Empowered Performance, including from an environmental point of view both during the production phase, in the subsequent phase of use by the customer and at the end of life.

The previous paragraphs illustrate the main strategies adopted to reduce environmental impacts linked to the choice of suppliers and raw materials (**upstream**), to the internal production process for the creation of the product (**core**), and now we would like to analyse the measures adopted for maximum performance in the **downstream** phase as well, i.e. sustainability even during use and at the end of its life, when it is decommissioned and sent for disposal.

The main features and environmental benefits of OMAL valves and actuators during use are summarised below:

PNEUMATIC ACTUATORS		VALVES	
Features and benefits			
Long service life (up to 1,000,000 cycles)		Long service life (high cyclicalilty)	
No maintenance required during use		High maintainability (easy component replacement)	
No need for lubrication		High recyclability of materials (100% recovery of metal components)	
High recyclability of materials (100% recovery of metal components)		Prevention of environmental pollution thanks to the outside sealing system	
Functional safety guaranteed up to SIL 3		Functional safety guaranteed up to SIL 3	
ENERGY EFFICIENCY		RELIABILITY AND DURABILITY	
One of the design priorities was to lower the amount of air required for operation. The Scotch Yoke system adopted guarantees significant energy savings: up to 40% less air consumed, ratio between weight and maximum torque delivered = -30% Kg/Nm.		OMAL guarantees greater reliability and duration of the valves in use thanks to the adoption of technical solutions to:	
Choosing the most suitable actuator size for the intended application allows you to minimise the use of compressed air and therefore save energy. OMAL can guarantee correct sizing as the manufacturer of the entire valve-actuator system.		<ul style="list-style-type: none"> <li>• reduce the wear of the moving elements in order to mitigate the effects on the seal and functionality of the product;</li> <li>• reduce the operating torque, consequently reducing the energy required for operation;</li> <li>• guarantee the maintainability of the product.</li> </ul>	

These characteristics allow our customers the maximum peace of mind according to our motto: **Do whatever you want while your OMAL valves work.**

## FOCUS: THE ENVIRONMENTAL IMPACTS OF THE NEW PNEUMATIC RACKON ACTUATOR

Respect for the environment and preventing pollution are the factors that inspired the design and construction of the new Rackon actuator:

### LOCAL SUPPLY CHAIN KM 0

Procurement and the few external processes are carried out by neighbouring companies, with a saving of CO<sub>2</sub> emitted into the environment.

### IN HOUSE PROCESS

Components such as the piston and cap are produced and processed internally to guarantee not only quality, but also the correct recycling of production waste.

### PACKAGING SUSTAINABILITY

The packaging used is 100% recyclable.

### ZERO MAINTENANCE

In normal applications, if installed and used correctly, it does not require maintenance.

### CIRCULARITY

Over 82% of the materials that make up the actuator can be recovered with a view to circular economy.

## FOCUS ON END OF LIFE

OMAL products are designed so that they can be completely disassembled at the end of their useful life, separating the various materials for their correct disposal.

All OMAL products are accompanied by a user manual that shows the list of raw materials used and an exploded view of the product that indicates where they are and how to dispose of them.

The choices made by OMAL in the design of its products make it possible to dispose of the materials and lubricants used in the category of SPECIAL NON-HAZARDOUS WASTE.

This is on condition that, during their use, they have not been polluted by substances included in the list of hazardous substances.

List of materials and instructions for disposal		
<b>Metals</b>	Aluminium	They can be sent to a processor as scrap.
	Die-cast aluminium alloy	
	Steel	
	Sintered bronze	
	Bronze	
<b>Techno polymers</b>	POM: acetal copolymer	They can be sent to a processor.
	PTFE: polytetrafluoroethylene	
<b>Elastomers</b>	NBR	They are in small quantities and dirtied with grease and metal particles due to use, for which they are classified as special non-hazardous waste.
	Polyurethane	
	FKM / FPM	
	Fluorosilicone	
<b>Packaging</b>	Wood	They are entirely recyclable and can be disposed of using the local sorted collection system.
	Cardboard	
	Paper	
	Polyethylene bags	

The focus on these aspects starts from the design of a new product. OMAL has tried to define a score to assess the environmental performance of the three new products manufactured.

The assessment is purely qualitative and does not seek to quantify the impact in terms of a LCA - Life Cycle Assessment.

The most environmentally critical aspects in the various phases of the life cycle of these three products were taken into consideration and each was assigned a weight.

Phase	Characteristics considered	Objective value
<b>Upstream</b>	External component supplies	Max 1/3
	Procurement logistics	Within 100 km
	Circularity of supplies	At least 1 supplier
	Number of materials used	Max 5
	Number of components	Max 20
<b>Core</b>	Number of treatments	Max 3
	Use of grease	Absence of grease
	Use of renewable sources	In-house processing for 90%
	Sustainability of packaging	Recycled cardboard
<b>Downstream</b>	Maintainability	Totale 100%
	Guaranteed number of cycles and useful life	1000.000 cycles
	Disassembly and recyclability at the end of life	100%

Based on the scores assigned to the various items with a percentage of achievement of the target value set for each, a final score was given on the basis of the following assessment grid:

Value	Score
89%	<b>A++</b>
80%	<b>A+</b>
70%	<b>A</b>
60%	<b>B++</b>
50%	<b>B+</b>
40%	<b>B</b>
30%	<b>D</b>
< 30%	<b>E</b>

## 5. ENVIRONMENT

The performance result of the three new OMAL products was more than satisfactory with a final rating in class A+ for each:

### RACKON

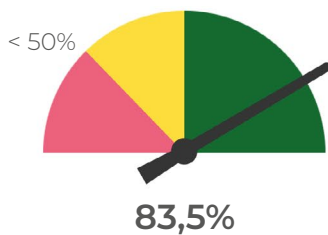

### VIP EVO

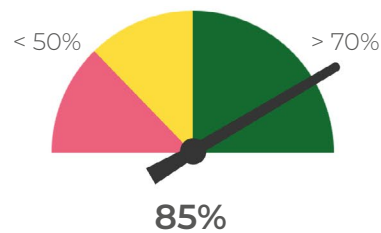

### KRATOS

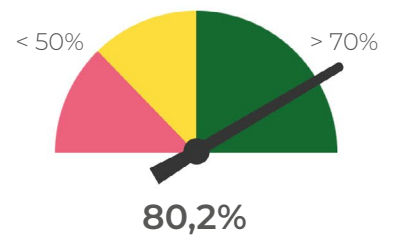

---

## 5.7 FUTURE PROSPECTS

- Increase sustainability in all Units;
- Improve the punctuality of data collection;
- Review and extend performance KPIs;
- New staff training plan with more hours on environmental aspects;









ECONOMIC VALUE  
AND REPUTATION

6

# ECONOMIC VALUE AND REPUTATION

## Material issues

Legal compliance and transparency

Economic soundness and investments

New markets

Brand reputation

A sustainable company is also a company capable of growing and lasting over time, which is why we consider it strategic to invest with a long-term perspective, aware that the value of our brand is based on our principles, as well as the consistency and transparency of our actions.

REVENUE 2019

32 MLN €

INVESTMENTS 2019

2,9 MLN €

EBITDA

3,16 MLN €

NET PROFIT

1,21 MLN €

NET ASSETS

6,42 MLN €

LEGALITY RATING 2019



Improved compared to the previous year

## Reference Goal - GRI (Global Reporting Initiative)

8 DECENT WORK AND ECONOMIC GROWTH



9 INDUSTRY, INNOVATION AND INFRASTRUCTURE



# 6.1 ECONOMIC RESULTS

The economic results are in line with last year and with the average market trend in the mechanical engineering sector.

Values in thousands of €	2017	% impact	2018	% impact	2019	% impact
Sales revenues	29.617	100,0%	31.434	100,0%	31.894	100,0%
EBITDA	2.678	9,0%	2.637	8,4%	3.164	9,9%
EBIT	1.327	4,5%	1.137	3,6%	1.481	4,6%
Result before tax	1.208	4,1%	1.045	3,3%	1.373	4,3%
<b>Profit for the year</b>	<b>861</b>	2,9%	<b>812</b>	2,6%	<b>1.218</b>	3,8%
Current Assets	15.330		17.405		19.112	
Fixed Assets	5.216		6.613		7.729	
<b>Total Invested Capital</b>	<b>20.546</b>		<b>24.018</b>		<b>26.841</b>	
Current Liabilities	12.116		14.480		14.034	
Consolidated liabilities	4.004		4.303		6.383	
Net capital	4.426		5.235		6.425	
<b>Total Funding Sources</b>	<b>20.546</b>		<b>24.018</b>		<b>26.841</b>	
Investments	2.014		2.863		2.933	
Number of employees	93		93		103	
ROS	4,48%		3,62%		4,64%	
ROI	6,46%		4,73%		5,52%	
ROE	19,45%		15,52%		18,95%	

## ADDED VALUE CREATED

Added value created	2018	2019
Net revenues from sales	30,7	31,2
Miscellaneous revenues and income	0,7	0,7
<b>Total added value created</b>	<b>31,4</b>	<b>31,9</b>

## ADDED VALUE DISTRIBUTED

Added value distributed	2018	2019
Remuneration of suppliers	16	15
Remuneration of workers	5,8	6,1
Remuneration of shareholders' capital	0,8	1,2
Social system remuneration (donations and sponsorships)	0,1	0,1
Public administration remuneration (taxes and fees)	0,2	0,2
<b>Total added value distributed</b>	<b>23,0</b>	<b>22,9</b>

## ADDED VALUE WITHHELD

Added value withheld	2018	2019
Amortisation	1,5	1,8
Provisions for risks	0,03	0,03
Financial income and expense	-0,1	-0,1
<b>Total value added withheld</b>	<b>1,4</b>	<b>1,7</b>

## 6.2 INVESTMENTS

Only a serious investment plan can guarantee the achievement of the growth, innovation and competitiveness objectives set, in other words the long-term solidity of a company. OMAL has defined an important two-year investment plan with a total value of € 5.8 million.

Investments 2018

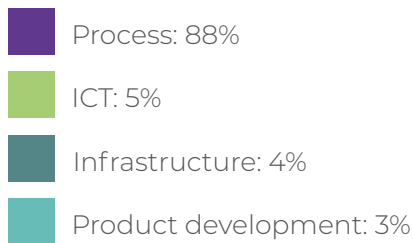
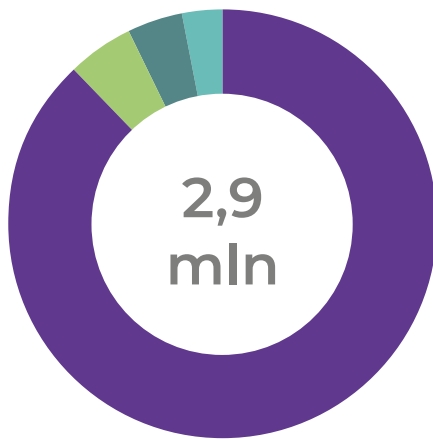

Investments 2019

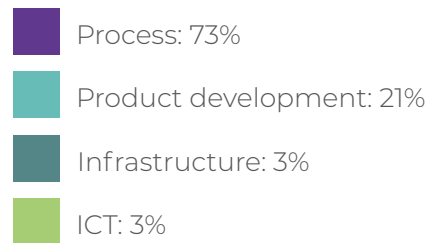
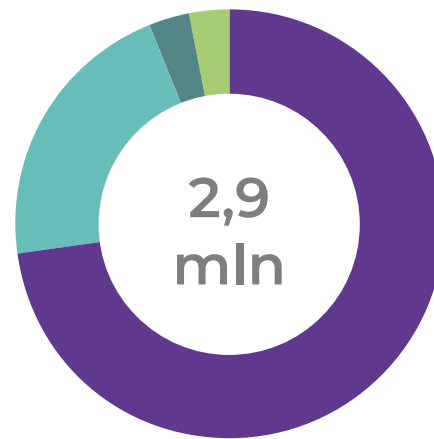

The annual amount of 2.9 million euro was divided differently over the two years over the various activities:

Area	2018	2019	Change %
Process	88%	73%	-15%
ICT	5%	3%	-2%
Infrastructure	4%	3%	-1%
Product development	3%	21%	+18%

As can be seen in 2019, activities and efforts were mainly directed towards the development of processes and new products that were launched on the market.



## 6.3 RATINGS AND AWARDS

### CRIBIS PRIME COMPANY

CRIBIS D&B, a leading company in the business information sector at international level, has recognised OMAL's maximum economic and financial reliability by assigning it a score of 1 and a minimum "risk of failure".

The "CRIBIS Prime Company" award is the highest level of evaluation of an organisation's commercial reliability and is issued only and exclusively to companies that constantly maintain a high economic-financial reliability and are virtuous in their payments to suppliers.

The excellent evaluation is even more significant when looking at the reference market where the average is 2 in the valve sector and 3 in the actuator sector.



# CRIBIS D&B EVALUATION

## CRIBIS D&B RATING

The CRIBIS D&B Rating is a synthetic indicator of the company's assets and risk. The financial assets are calculated on the basis of the Net Assets (from the financial statements or estimated) and the Share Capital, while the risk is derived from the CRIBIS D&B Failure Score. The indicator ranges from 1 (minimum risk) to 4 (maximum risk).

### Risk assessment

### Score factor

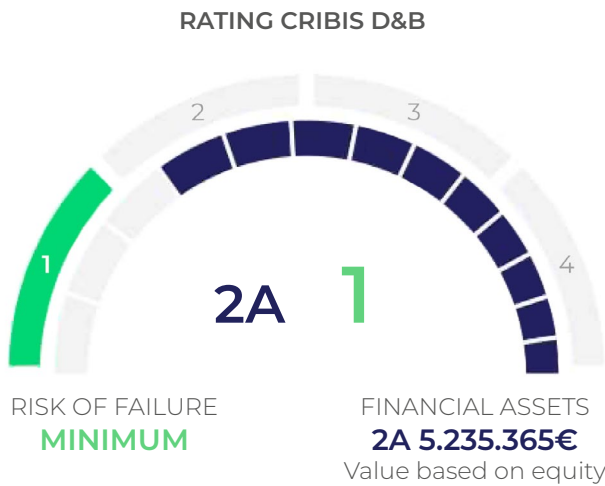

- The financial flow is satisfactory;
- The company has a medium level of debt;
- The current account tends to be balanced;
- the commitments made by the company are fulfilled with slight delays;
- The analyses carried out over the last 12 months show that the trend in payments is constant;
- The company has been operating on the market for some time.

# LEGALITY RATING

The Legality Rating is an innovative tool developed by the Italian Antitrust Authority (AGCM) in agreement with the Ministries of the Interior and Justice, which rewards companies that operate according to the principles of legality, transparency and social responsibility.

OMAL decided to join voluntarily in 2017 to have maximum transparency in its commercial relations.

This is a synthetic indicator of compliance with legality standards, the score varies from one to three stars: one star the company respects legality; two or three stars the company meets additional requirements in addition to legal obligations. Each additional requirement is given a "+" and after three "+" a star is added. OMAL improved its 2017 performance by two stars, reaching the new rating:



## 6.4 MARKET PRESENCE AND COMMERCIAL DEVELOPMENT

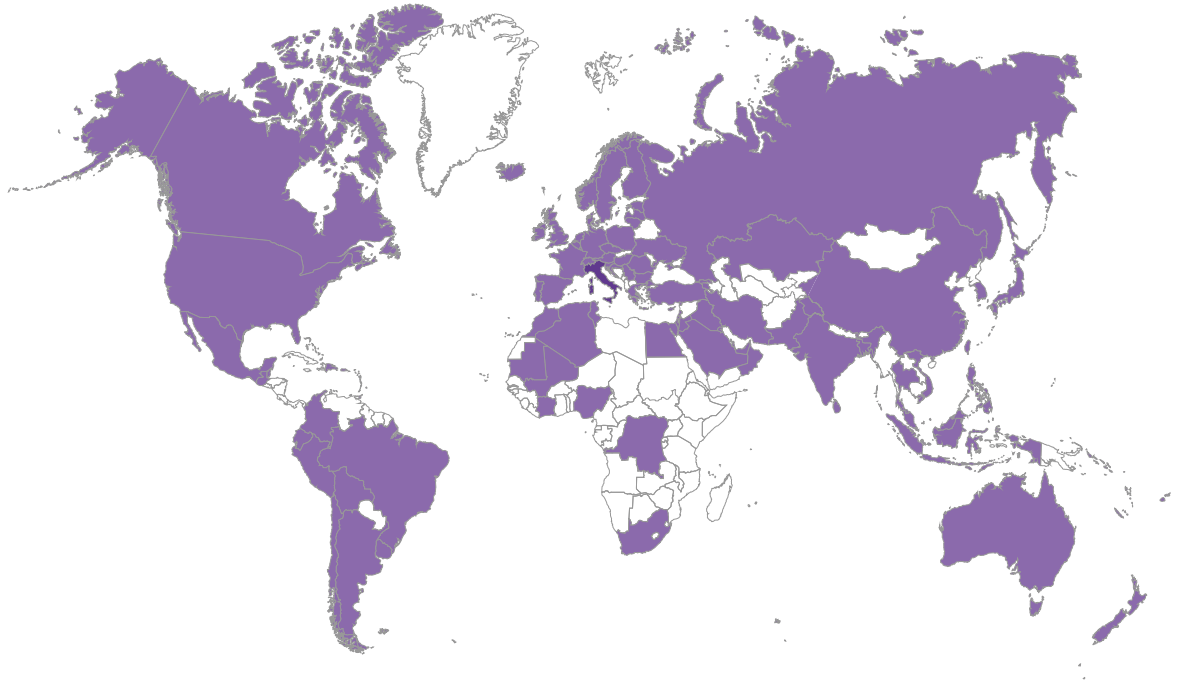

The customer is one of the most important stakeholders in measuring the effectiveness of our decisions and the adequacy of the resources employed, and their satisfaction is at the centre of the company's efforts to achieve continuous improvement.

OMAL's philosophy expressed in the motto "EMPOWERED PERFORMANCE" sums up the company's desire to give the market a product and service that is superior to the reference technical and quality standards in the industry concerned.

OMAL differentiates its customers according to their type (i.e. distributor, machine manufacturer or engineering company, end customer, etc.), then dividing them according to their industrial sector and according to the product lines supplied.

At an operational level, customers are distinguished according to their geographical area of origin and managed by the Sales Department with a dedicated Area Manager and back-office resource. Exceptions are customers defined as "executive", who are particularly important in terms of sales or are strategic, and who are managed directly by the Sales Department.

Today OMAL has a presence in about 100 countries directly or thanks to a network of distributors and agents able to serve the different industrial sectors.

Turnover divided by geographic area and the trend compared to the previous year are shown below:

## Turnover 2019

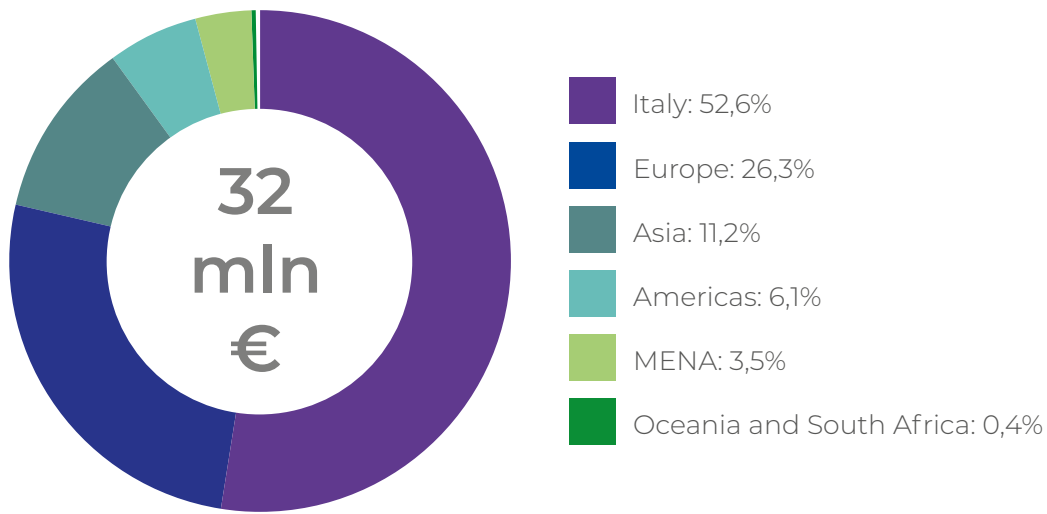

Geographic area	2018	2019	Change %
Italy	52,8%	52,6%	-0,2%
Europe	24,8%	26,3%	+1,5%
Asia	13,2%	11,2%	-2%
Americas	5,5%	6,1%	+0,6%
MENA	3,4%	3,5%	+0,1%
Oceania and South Africa	0,4%	0,4%	-

Our presence in Italy is stable and can count on a consolidated network of loyal customers. The diversification of products and sectors of use has allowed us to expand into foreign markets thanks to our ability to supply both valves and actuators and complete systems ready for in-line installation.

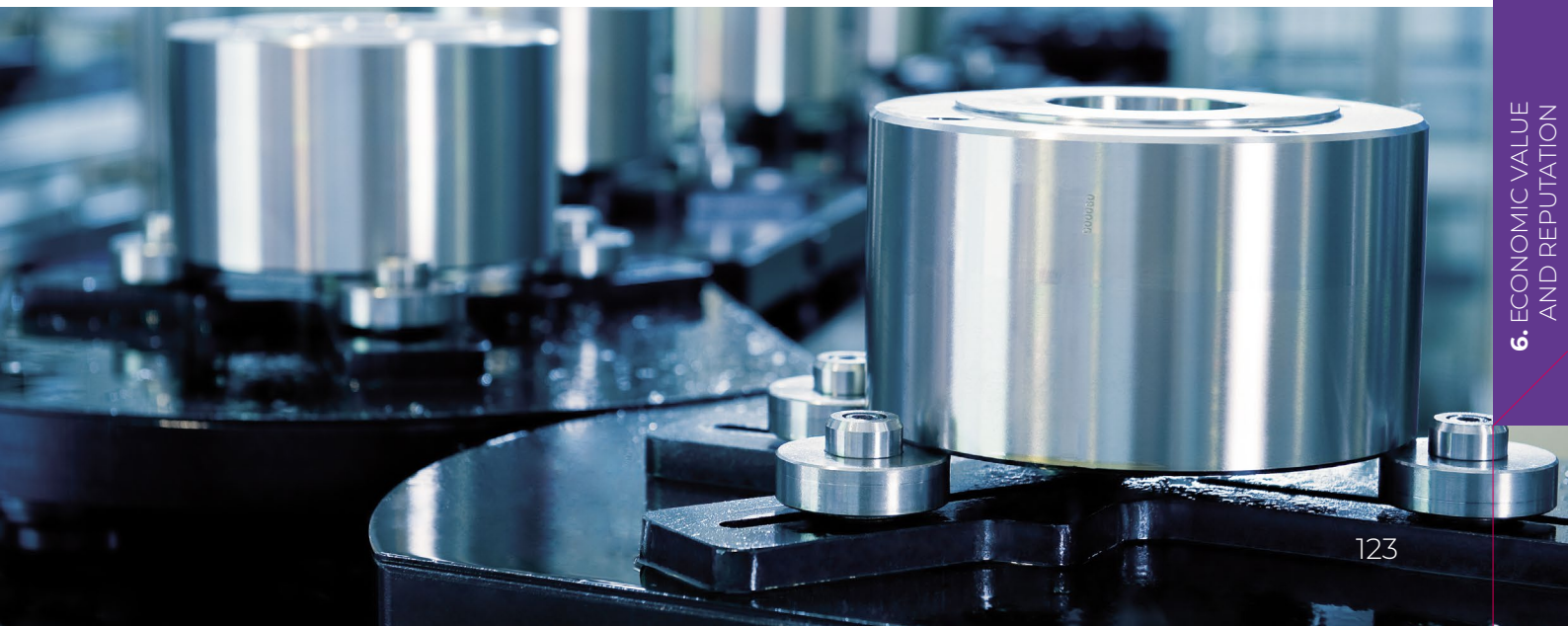

## 6.5 SALES CONFERENCES AND FAIRS

A product with EMPOWERED PERFORMANCE is characterised not only by its high technical qualities, but also by the prompt assistance and technical support service always able to meet the needs of its customers (*solution provider*).

For this reason OMAL has opened several channels of communication and commercial upgrade, to train and refresh the sales network and distributors and to satisfy our customers. The most important events include trade fairs, sales conferences and training days specific to our distribution chain.

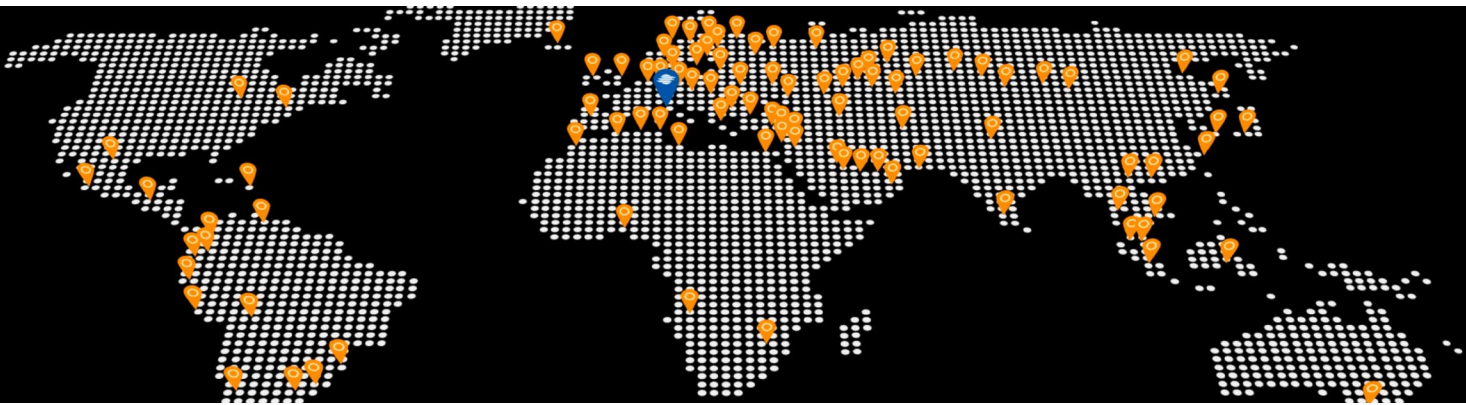

### FAIRS

As laid out in the strategic plan, in 2019 OMAL participated in various trade fairs and was able to show its guests the fruit of careful research and design work and the care taken in manufacturing our valves and actuators. This also leveraging cutting-edge audio-visual support tools such as 3D movies and video tutorials for the maintenance of their products.

The following are the main trade fairs we attended:



#### WLPG FORUM 2019

24 - 26 September 2019 - Amsterdam

The event combined the LPG World Forum and the annual European Congress and was held in Europe as a recognised global leader in promoting initiatives to encourage the use of alternative fuels and reduce air pollution. Attendance at the event was strong and brought together premium LPG companies, decision-makers, policymakers and users. OMAL reaffirmed its leadership as a manufacturer of valves and actuators for this sector with a number of customer visits that almost tripled compared to the previous edition and from as many as 28 foreign countries.

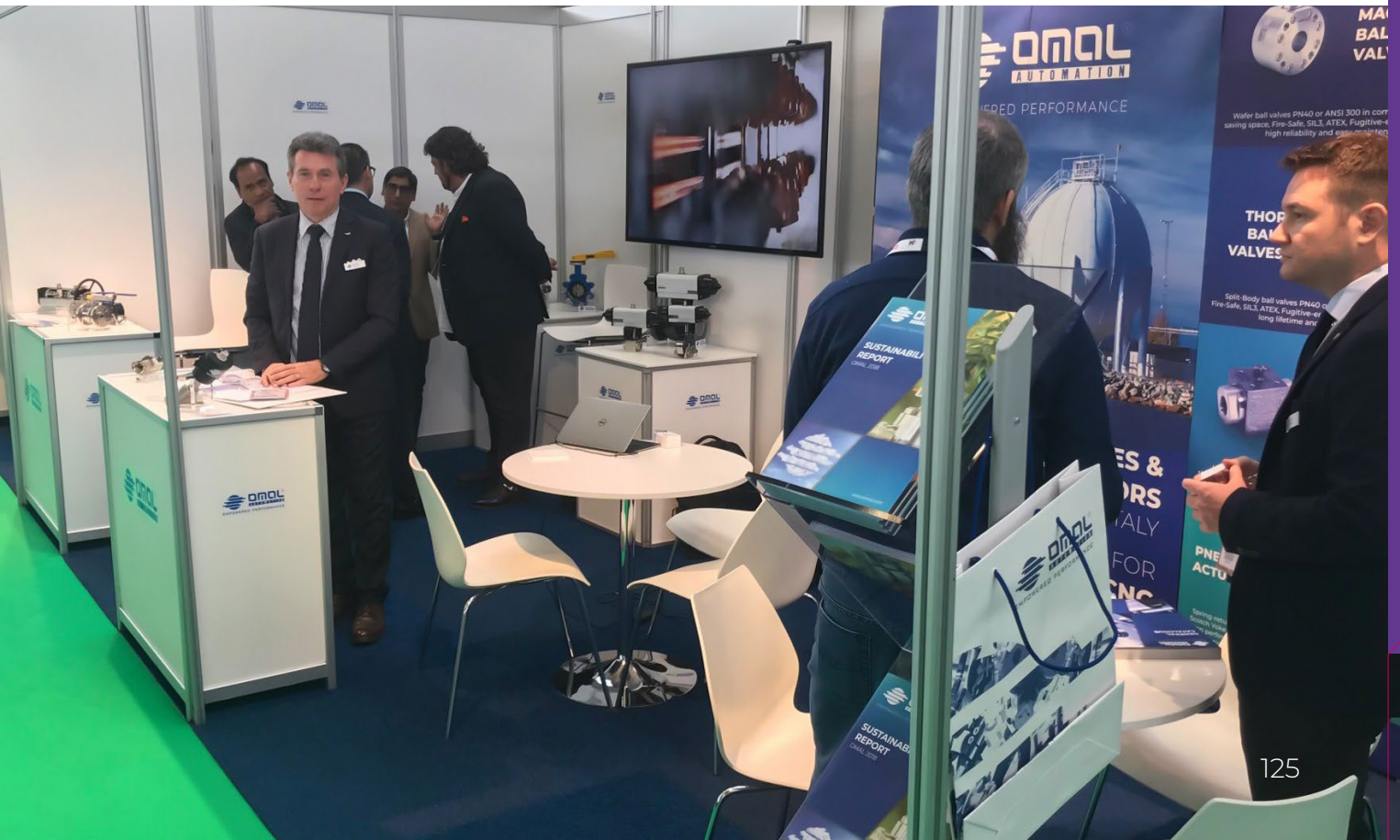



## IVS – INDUSTRIAL VALVE SUMMIT 2019

22 - 23 May 2019 - Bergamo

OMAL participated in the third edition of **Industrial Valve Summit (IVS)**, the most important international event dedicated to industrial valve technologies and flow control solutions, promoted by Confindustria Bergamo and Ente Fiera Promoberg, which was held in Bergamo on May 22 and 23. Visits to our stand, slightly down on the previous year's edition, came from 18 countries in addition to Italy, with a 22% attendance of customers compared to suppliers.



## OMC 2019

27 - 29 March 2019 - Ravenna

OMC is the "Offshore Mediterranean Conference and Exhibition" a leading event for the energy industry, producers and users of plants, process instrumentation and offshore installations. Now in its 14th edition, it has become consolidated as one of the most important meeting places for all operators in the Oil & Gas industry (engineers, decision-makers, scientists, academia and manufacturing companies). Launched in 1993 as a Mediterranean fair, it recorded a remarkable growth in terms of conference visitors and quality, thus carving out an international value for itself.



## SALES CONFERENCE AND TRAINING FOR THE DISTRIBUTION CHAIN

Since 2010, OMAL has established a fixed meeting with its network of Italian agents and foreign distributors, as a tool for continuous updating in order to promote new products, share commercial strategies and network with partners.

In 2018 a two-day sales conference was held at the Italian headquarters to show the result of the considerable efforts made in the reorganisation of the Group's production facilities.

In 2019, on the other hand, we preferred to focus on specific training for the distribution chain, organising, almost always on our premises, some two-day events, divided by area of origin of the distributors:

**February 2019:** Training session for a first group of distributors from different parts of the world for an update on the advantages of OMAL products and to share experiences.

**February 2019:** we visited Otkonsaş A.S., a Turkish distributor who has been collaborating with OMAL for over 25 years.

**March 2019:** Training session with our partner Prodim, a point of contact for the Netherlands and Belgium area.

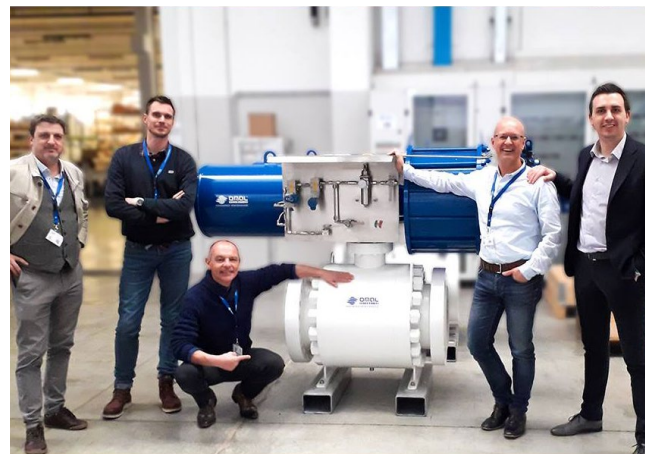

**April 2019:** Meeting with Italian agents to present all the news on OMAL products and tools and to collect suggestions and comments that will help us to improve further.





**April 2019:** OMAL process valve training session with our **distributors from Russia, Ukraine and Poland.**



## 6.6 INTANGIBLE ASSETS AND REPUTATION

The value of a company cannot only be measured with economic and sales data, but is also made up of intangible assets that contribute to determining the ability to successfully pursue organisational goals over time. These distinctive assets, difficult to imitate by competitors, have always been pursued by OMAL as strategic to create knowledge within the company, an organisational culture, a sense of belonging, the ability to create relationships with the territory and the surrounding ecosystem, promoting actions of social and environmental impact.

The intrinsic and distinctive value contained in OMAL valves and actuators therefore has to do with its ability to create virtuous relationships with internal and external stakeholders and supply chain networks, to respect and protect the environment, the health and safety of our workers, the quality of Made in Italy products, but also to protect the social context that surrounds it.

While we are writing this Report, Italy, and in particular our Province of Brescia, is experiencing a difficult moment of health emergency due to the spread of the COVID-19 virus.

OMAL wanted to make its contribution by donating 50,000 euros to the Fondazione Spedali Civili di Brescia, which will be used to purchase equipment and B-PAP ventilators, which are essential to increase the number of intensive therapies available in the hospital and save lives.

This is the company's concrete response to the needs of the surrounding area, pursuing the values that have always inspired its work.

## FOCUS: VALVEcampus

OMAL has decided to become a member of VALVEcampus, an Italian association whose aim is to promote the valve market and the made in Italy worldwide.

The reasons for this choice are many, first of all to **network** with associates, an opportunity for dialogue between sector technicians and to **share information** on the main international buyers and on the reference markets.

The VALVEcampus association also has the purpose of promoting training initiatives for technicians and specialists to keep up with the developments of this constantly evolving sector.



---

## 6.7 COMMUNICATION AND MEDIA PRESENCE

**A**t the identity level, nothing succeeds in restoring the perception of a company's values like its communication, to the point of becoming a real strategic asset to strengthen relations with direct and indirect, external and internal stakeholders. The importance of communication is not only to be understood in relation to the strength of its message, but also in relation to the methods chosen to spread it and the channels devised to convey it.

In the last two years painstaking work has been done to update and restyle all the main channels of communication to the outside world such as:

**CORPORATE VIDEO** > which shows the two sites in Rodengo Saiano and Passirano in 5 minutes and travels through the offices, meeting rooms, production departments, assembly and warehouse to get to the product with detailed footage that “explodes” into 3D lines, accompanied by compelling music. The video then closes with an overview of the OMAL network around the world.



Watch corporate video



**WEB SITE >** Characterised by:

- responsive graphic design to adapt it to smartphone and tablet displays;
- an online valve and actuator configurator;
- the ability to view all products in the catalogue, also in 3D;
- the possibility to log in to consult the prices of the items;

The next goal will be to make the website available in 9 languages (Italian, English, German, Spanish, French, Portuguese, Turkish, Chinese and Russian).

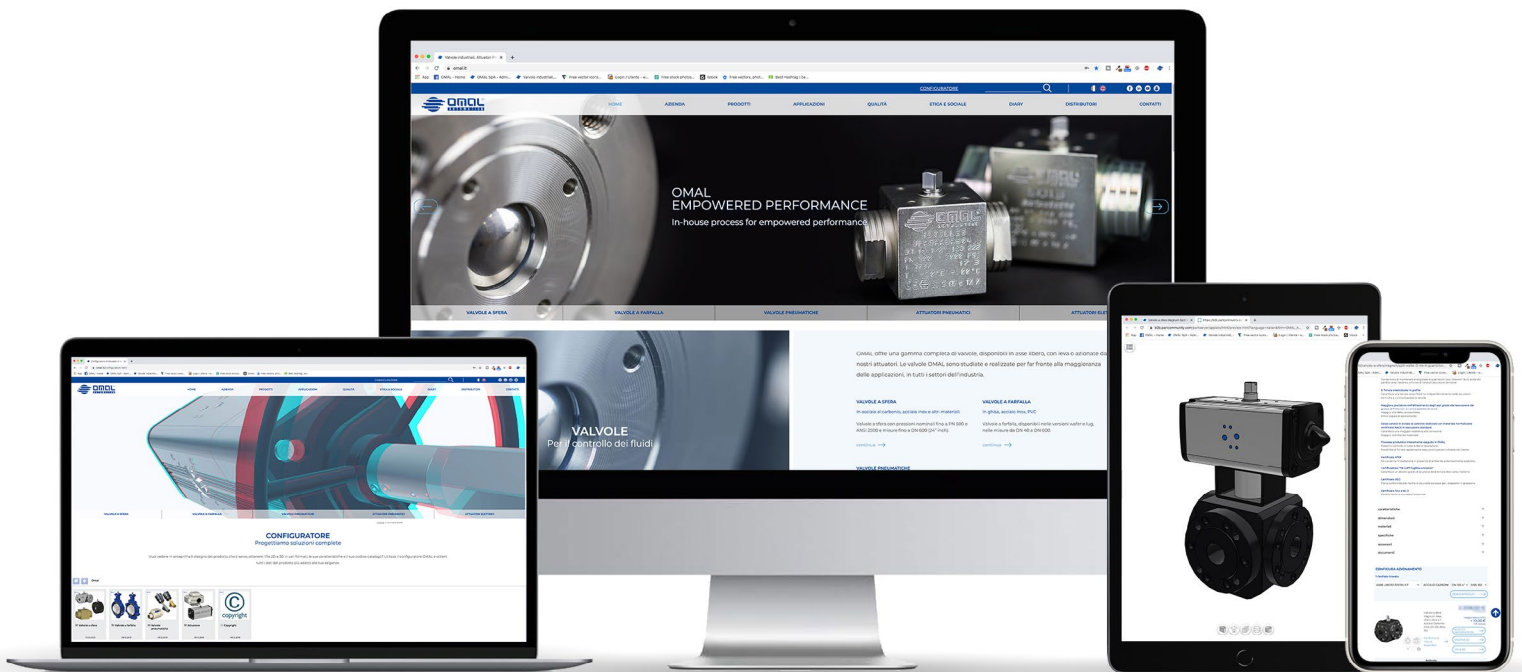

**VIDEO 3D IN VIRTUAL REALITY >** to recreate a real virtual journey to discover three OMAL products (VIP, ARES and PROCHEMIE) and to be presented at various fairs, thanks to a 3D station with headsets and sensors. The all-round experience makes it possible to understand the added value of the products, capturing outstanding design and functional details, thanks to the “exploded” view of the item. The video is also available on YouTube and can be viewed in 3D from a computer or smart-phone.



Watch 3D videos



**APP OMAL >** for smartphones and tablets, allows customers to consult the entire product catalogue and configure the valve and actuator according to their needs. The OMAL sales network can also consult the prices of each item, view and download the related 3D and place and send orders. In 2019, further work was done to align the APP with the website.

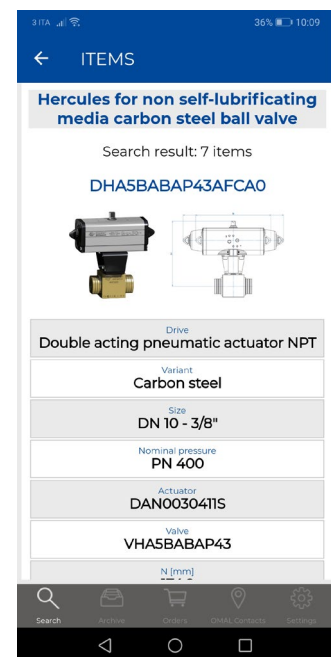

**COMMUNICATION CAMPAIGN 2019** > During 2019, a **corporate identity** project was carried out to align all OMAL catalogues and standardise the corporate image according to a coordinated communication line for all communication channels used by the company: **fairs, advertising, industry magazines, social media** etc.

The subject chosen for this communication campaign was born from a study of the target group to analyse OMAL's positioning by brand reputation and brand image, as well as to examine how the company is perceived and what customers (or potential customers') expect from OMAL products and services. From these analyses it emerged that OMAL's typical customer is looking for a superior quality valve, in its technical specifications and construction characteristics, because they want to be **certain of the product's performance and minimise the risk that the valve will fail or become blocked within their plant.**

The concept of the new campaign therefore focused on the priority requirement of OMAL's customer: to have **maximum peace of mind and reliability when it comes to the performance of valves and actuators.** In order to achieve the objective, a brand association process was set up in order to associate the OMAL brand with the concept of problem-free, relaxation. In terms of style and graphics, the campaign aimed to differentiate itself from other sector advertisements (mainly in magazines and exhibition stands) which are particularly technical and cold, so as to stand out both in magazine leaflets and in its presence at exhibitions. To this end, we went in search of emotional images that went beyond the sector's visual communication standard. The focus was shifted to the emotional factor, with references to situations of relaxation, no worries, with the objective that the user, when flicking through the magazine, will find an emotional image that stands out and captures their attention.

When developing the concept, the challenge of succeeding in bringing emotion to such an industrial, technical and therefore cold product (valves and actuators) with a low emotional appeal was immediately established. The objective has been pursued by placing the product -valve/actuator- alongside images that emotionally evoke a sense of tranquillity; the sensation of being able to dedicate oneself to what we like most, without thinking. Choosing, as the guiding thread of the whole campaign, the claim:

## “Do whatever you want. While your OMAL valves work”

The aim was not so much to talk to the user in their corporate role, but directly to man; aiming to touch more intimate strings, linked to the personal and therefore emotional sphere.

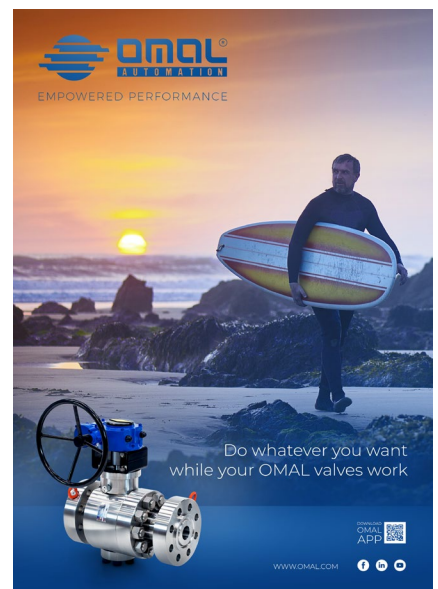



EMPOWERED PERFORMANCE



Do whatever you want while your OMAL valves work

DOWNLOAD  
OMAL  
APP



WWW.OMAL.COM



6. ECONOMIC VALUE  
AND REPUTATION

## THE CAMPAIGN APPLIED TO FAIRS >



Do whatever you want, while your OMAL valves work.

After visiting the fair, do not miss Amsterdam best museums and points of interest. Here are the best locations and restaurants within 30 minutes walk from the fair.

MUST SEE	Distance
Beatrixpark	8 min
Amstelpark	20 min
Heineken Experience	25 min
Rijksmuseum	30 min
Vondelpark	30 min
Van Gogh Museum	30 min
Moco Museum	30 min
Stedelijk Museum	30 min

RESTAURANTS	Distance
The Roast Room	2 min
Visaandeschelde	5 min
Sazanka	12 min
EN Japanese Kitchen	16 min
Sinne	18 min
Bolenius	19 min
Brasserie Van Baerle	24 min
Le Garage	27 min

[WWW.OMAL.COM](http://WWW.OMAL.COM)





**OMAL<sup>®</sup>**  
AUTOMATION  
EMPOWERED PERFORMANCE

Do whatever you want  
while your OMAL valves work

**OMAL<sup>®</sup>**  
AUTOMATION  
EMPOWERED PERFORMANCE

## THE CAMPAIGN APPLIED TO SOCIAL MEDIA >



**OMAL SpA**  
· 25 giugno ·

🔥 Do whatever you want. While your OMAL valves work

You are finally about to sail for your well-deserved holiday! All of a sudden a call warns you that your plant has stopped working because of a breakdown...so much for your excursion plans! 🤖

Not the best way to start vacation time!  
Forget all this: With OMAL valves and actuators working in your system you do not need to worry about anything and you can dedicate yourself to what you like best.

Thanks to the empowered performance of our products we can guarantee a high standard of safety and reliability: we test 100% of our products reducing failures to the minimum

What are your plans for this summer then?

#OMAL2019 #OMAL #OMALAdv2019 #ADV #Advertising #Valves #OMALValves #MadeInItaly #ItalianManufacture #Italy #DoWhateverYouWant — presso OMAL SpA.



**OMAL SpA**  
· 11 luglio ·

🌊 Do whatever you want. While your OMAL valves work

Can you imagine something more exciting and relaxing for this summer than exploring the seabed 🌊🐠, literally immersed in nature, carefree and above all without worrying that something will not work in your plant.... 🤖🤖🤖

Trust OMAL products empowered performance dedicating your energy and thoughts to what you like best.

The design specifications and the high quality standards of OMAL valves and actuators guarantee a very high safety and stability level that minimizes the risk of failure.

What about you? What are your plans for this summer? 🌞

Discover the Supreme Trunnion Valve Ball by OMAL: <https://www.omal.com/products/ball-valves/supreme-trunnion/supreme-trunnion-ball-valve.html>

#OMAL2019 #OMAL #OMALAdv2019 #ADV #Advertising #Valves #OMALValves #MadeInItaly #ItalianManufacture #Italy #SupremeTrunnion #BallValve #DoWhateverYouWant #Summer #Holidays #Sea #Snorkeling #ScubaDiving — presso OMAL SpA.

**THE OMAL CALENDAR** > Every year OMAL creates a personalised desk calendar that it distributes to its stakeholders. For this year's calendar the subject "Do whatever you want. While your OMAL valves work ." was applied to the territory where OMAL products are born: the province of Brescia and Franciacorta. All the valves and actuators produced by OMAL are in fact designed and manufactured in the factories in the province of Brescia.

The calendar is a real invitation to all stakeholders to visit OMAL factories and discover the product design, production and testing processes. But at the same time it is an unmissable opportunity to discover the beautiful places that surround the company, which can be visited just a few kilometres away. The aim is to raise awareness of and promote the places in Brescia, as well as to enhance the **Made in Italy** - or better "**Made in Home**" -, claim typical of OMAL products.



**THE COMMUNICATION CAMPAIGN IN NUMBERS >** With this campaign, for the first time, a uniform communication plan was set up, aimed at a coherent and systematic target audience.

During the year:

- **10 out of 10 ADV** published in trade magazines were focused on the theme of the campaign.
- **3 out of 3 fairs** OMAL attended during the year had the campaign as the main subject of the communication (or presented references to the campaign). OMAL's trade fair presence stood out in the sector for its originality and emotional appeal.

• **19 out of 83 posts published on the company's Social Media** were connected to the campaign;

Recording a total of:

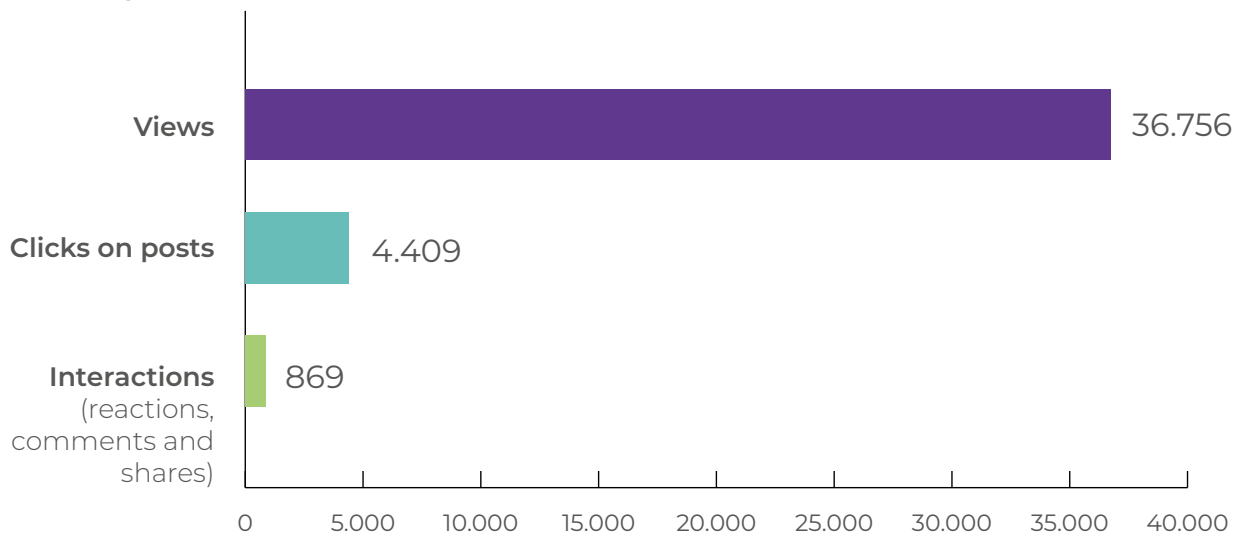

Data calculated only on the total number of posts related to the advertising campaign, published on the Facebook and LinkedIn company pages.

**COMMUNICATION ON SOCIAL MEDIA** > The objective of corporate communication was also to develop an editorial plan that would guarantee a constant presence on social media, an increasingly strategic communication channel to raise awareness of our company.

The purpose of these communication campaigns is not only to present adverts, but also and above all to tell the story of the OMAL world, ongoing activities and projects, reports of our business trips and/or fairs, and corporate events.

The story “**What’s on OMAL**” is laid out not only through traditional images, but also with videos that take a few seconds to showcase a PLUS of an OMAL department or of a product in a much more effective way.



## What’s on OMAL



## 6. ECONOMIC VALUE AND REPUTATION

We therefore have several post trends:

**OMAL Features&Benefits:** a series of graphics that illustrate the pluses, features and benefits of OMAL products.



**News and Events:** dedicated to events apparently far from the world of valves and actuators, but embedded in OMAL products.

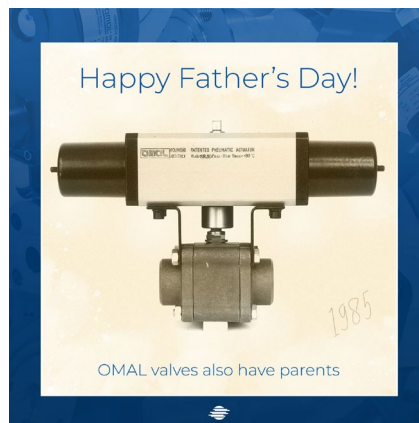
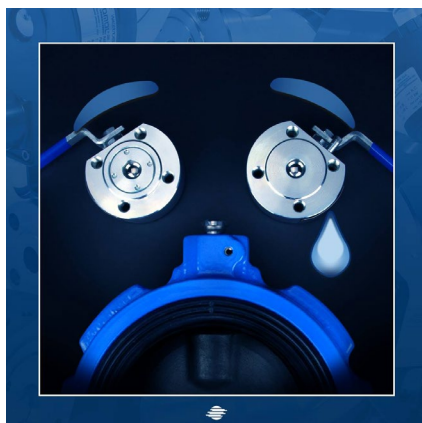

Participation in trade fairs or sales conferences.



OMAL's sensitivity and commitment to social issues.



OMAL's commitment to the environment.



Sharing of projects, initiatives and awards.





## 6.8 FUTURE PROSPECTS

Aware of living in a national and international context that is not easy to understand due to various factors linked mainly to the spread of the Coronavirus, but also to Brexit, relations between China and the USA or instability in the Middle East, it is currently not easy to predict what the future social, economic and political implications will be. After a general risk assessment, the 2020 Strategic Plan has been defined and will be based on market and organisational objectives.

At the heart of the competitive strategy is the desire to be closer to the US market with the opening of a company branch there in 2020, a warehouse and the definition of a marketing plan that foresees a gradual introduction of our products to the US market.

At the organizational level, new investments and activities are planned for:

- acquisition of new machinery;
- expansion of buildings and operating spaces;
- implementing a Safety Management System;
- guaranteeing maximum data security;
- defining ad hoc KPIs for all operations;
- simplifying internal processes and information flows;
- promptly monitoring consumption;
- defining milestones for the management of strategic projects;
- training staff to increase skills;
- designing new products;
- activating an e-commerce channel;
- making the website available in 7 new languages;
- defining the new advert and the coordinated image with videos/interviews for the launch of new products;
- participating in fairs;
- digitising controls in production and testing;
- exiting from strategic single-supplies;
- improving company filing;

Upcoming fairs:







# ANNEXES

# GRI CORRESPONDENCE TABLE

GRI Standards	Description	Page
<b>GENERAL SECTION</b>		
<b>Organisational profile</b>		
102-1	Name of the organisation	cover
102-2	Activities, brands, products and services	10-11, 60-66
102-3	Location of headquarters	10-11
102-4	Location of operations	122-123
102-5	Ownership and legal form	14
102-6	Markets served	122-123
102-7	Scale of the organisation	38, 117
102-8	Information on employees and other workers	38, 39
102-9	Supply chain	72-78
102-10	Significant changes to the organisation and its supply chain	23
102-11	Precautionary principle or approach	22
102-12	Adoption of codes of conduct (economic, social and environmental)	13, 75, 89-90
102-13	Membership of associations	16, 46-48, 130
<b>Strategy</b>		
102-14	Statement from senior decision-maker	9
102-15	Risks and opportunities	14, 23, 89-90, 145
<b>Ethics and integrity</b>		
102-16	Values, principles, standards and norms of behaviour	12, 41, 46-48, 53-54, 74-75, 87, 120-121
<b>Governance</b>		
102-18	Governance structure	14

<b>Stakeholder Engagement</b>		
102-40	List of stakeholder groups	30-32
102-41	Collective bargaining agreements	38-39
102-42	Identifying and selecting stakeholders	32-33
102-43	Approach to stakeholder engagement	30, 31
102-44	Key topics and concerns raised	23, 26-27
<b>Reporting practice</b>		
102-45	Entities included in the consolidated financial statements	30-32
102-46	Defining report content and topic boundaries	22
102-47	List of material topics	26-27
102-48	Restatements of information	na
102-49	Changes in reporting (material issues, reporting perimeter)	22
102-50	Reporting period	22
102-51	Date of the most recent report	22
102-52	Reporting cycle	22
102-53	Contact point for questions regarding the report	copertina
102-54	Claims of reporting in accordance with the GRI Standards	22
102-55	GRI content index	148-153
102-56	External assurance	na
<b>Management approach</b>		
103-1	Explanation of the material topic and its boundary	20, 26-29
103-2	The management approach and its components	22-27
103-3	Evaluation of the management approach	28-29

<b>GRI Standards</b>	<b>Description</b>	<b>Page</b>
<b>ECONOMIC PERFORMANCE</b>		
<b>Economic management</b>		
103-1	Explanation of the material topic and its boundary	12-15, 24-27
103-2	The management approach and its components	14-16, 22-27
103-3	Evaluation of the management approach	13
<b>201</b>	<b>Economic performance</b>	
201-1	Direct economic value generated and distributed	117-118
<b>203</b>	<b>Indirect economic impacts</b>	
203-1	Infrastructure investments and services supported	48
	Investments in research and development	119-120
<b>204</b>	<b>Procurement practices</b>	
204-1	Proportion of spending on local suppliers	78-80, 93-94
<b>205</b>	<b>Anti-corruption</b>	
205-1	Operations assessed for risks related to corruption	13

GRI Standars	Description	Page
<b>ENVIRONMENTAL PERFORMANCE</b>		
<b>Environmental management</b>		
103-1	Explanation of the material topic and its boundary	86
103-2	The management approach and its components	87-90
103-3	Evaluation of the management approach	88-89
<b>301 Materials</b>		
301-2	Recycled input materials used	91
<b>302 Energy</b>		
302-1	Energy consumption within the organisation	93-97
302-4	Reduction of energy consumption	93-95
302-5	Reductions in energy requirements of products and services	108
<b>303 Water and effluents</b>		
303-1	Interactions with water as a shared resource	98-100
303-5	Water consumption	98-99
<b>305 Emissions</b>		
305-1	Direct (Scope I) GHG emissions	102
305-2	Indirect (Scope II) GHG emissions	103
305-5	Reduction of GHG emissions	103-104
<b>306 Waste</b>		
306-2	Waste by type and disposal	101-102
<b>307 Environmental compliance</b>		
307-1	Non-compliance with environmental laws and regulations	89-90
<b>308 Supplier environmental assessment</b>		
308-1	New suppliers that were screened using environmental criteria	76-78

<b>GRI Standards</b>	<b>Description</b>	<b>Page</b>
<b>SOCIAL PERFORMANCE</b>		
<b>Social management</b>		
103-1	Explanation of the material topic and its boundary	21, 36-37, 41, 44-48
103-2	The management approach and its components	20-21, 24-26, 29-32
103-3	Evaluation of the management approach	46
<b>401 Employment</b>		
401-1	New employee hires and employee turnover	38-39
<b>403 Occupational health and safety</b>		
403-1	Occupational health and safety management system	44-45
403-2	Hazard identification, risk assessment, and incident investigation	44
<b>404 Training and education</b>		
404-1	Average hours of training per year per employee	42-43
404-2	Programmes for upgrading employee skills and transition assistance programmes	42-43
<b>412 Human rights assessment</b>		
412-1	Operations that have been subject to human rights reviews or impact assessments	75
<b>413 Local communities</b>		
413-1	Operations with local community engagement, impact assessments and development programmes	46-48
<b>414 Supplier social assessment</b>		
414-1	New suppliers that were screened using social criteria	74-75
<b>417 Marketing and labeling</b>		
417-1	Requirements for product and service information and labeling	60-65
<b>419 Socio-economic compliance</b>		
419-1	Non-compliance with laws and regulations in the social and economic area	13





# GLOSSARY

## AA1000

Regulations published by AccountAbility that provides organisations with the tools to manage sustainability.

## Environment

### (extracted from ISO 14001)

Surroundings in which an organisation operates, including air, water, land, natural resources, flora, fauna, humans and their interrelation.

## Other GHG emissions

GHG emission other than indirect GHG emissions from energy consumption, which is a consequence of the activities of an organisation, but which arises from GHG sources owned or controlled by other organisations.

## Carbon Footprint

Carbon Footprint (Source: Ministry of the Environment and Protection of the Land and Sea) The carbon footprint is a measurement that expresses total

GHG emissions directly or indirectly associated with a product, organisation or service in CO<sub>2</sub> equivalent.

In accordance with the Kyoto Protocol, the greenhouse gases to be included: carbon dioxide (CO<sub>2</sub>), methane (CH<sub>4</sub>), nitrous oxide (N<sub>2</sub>O), hydrofluorocarbons (HFCs) and sulphur hexafluoride (SF<sub>6</sub>) and perfluorocarbons (PFCs). The tCO<sub>2</sub>e (tonnes of CO<sub>2</sub> equivalent) allows the greenhouse effect produced by these gases to be expressed in reference to the greenhouse effect produced by CO<sub>2</sub>, considered to be 1 (for example, methane has a greenhouse potential of 25 times that of CO<sub>2</sub>, so one tonne of methane is measured as 25 tonnes of CO<sub>2</sub> equivalent).

The measurement of the carbon footprint of a product or process requires in particular the identification and quantification of the consumption of raw materials and energy in selected phases of the life cycle of the product or process.

## CO<sub>2</sub> eq (carbon dioxide equivalent):

Parameter used to compare the emissions of various greenhouse gases on the basis of the Global Warming Potential (GWP). The value of CO<sub>2</sub> equivalent of a gas is obtained by multiplying its overall weight by the relative GWP.

## Conflict minerals

Minerals extracted in conditions of armed conflict and violation of human rights that come from the Democratic Republic of Congo and neighbouring countries. Use in the USA is regulated by the Dodd-Frank Act.

## Direct energy consumption

Consumption relating to the use of primary energy sources (methane gas, fuel, etc.) within areas owned or controlled by the organisation. For example, the consumption of methane gas for the operation of heating systems installed at sites of the organisation.

## Indirect energy consumption

Consumption relating to the use of primary energy sources (coal, natural gas, fossil fuels, etc.) outside areas owned or controlled by the organisation. For example, the consumption of electricity purchased from an energy provider that uses primary energy sources at its sites to produce electricity.

## GHG emission

Total mass of a GHG released into the atmosphere over a specified period of time.

## Direct GHG emission

GHG emission from greenhouse gas sources owned or controlled by the organisation.

## Indirect GHG emission from energy consumption

GHG emission deriving from the production of electricity, heat or steam imported and consumed by the organisation.

## FSC

Forest Stewardship Council.

This mark identifies products containing wood from forests managed properly and responsibly according to strict environmental, social and economic standards. FSC is an international certification that allows organisations to guarantee on the market the origin of the wood or paper used for their products, thus demonstrating its active contribution to responsible forest management in a correct, transparent and controlled manner.

## Greenhouse gas (GHG)

Gaseous constituent of the atmosphere, both natural and of anthropogenic origin, which absorbs and emits radiation at specific wavelengths within the spectrum of infrared radiation emitted by the Earth's surface, atmosphere and clouds. GHGs include carbon dioxide (CO<sub>2</sub>), methane (CH<sub>4</sub>), nitrous oxide (N<sub>2</sub>O), hydrofluorocarbons (HFC), perfluorocarbons (PFC) and sulphur hexafluoride (SF<sub>6</sub>).

## Green Procurement

Integration of environmental considerations in product and service procurement procedures, taking into account environmental impacts in the course of their life cycle, from the extraction of raw materials to the disposal of waste. Environmental impact (extracted from EN ISO 14001:2004) any change to the environment, whether adverse or beneficial, wholly or partially resulting from an organisation's environmental aspects. ISO 9001 International standard that defines the requirements of an organisation's quality management system. This standard provides guidelines for improving effectiveness and efficiency in the creation of a product or in the provision of a service and for increasing customer satisfaction and loyalty.

## Environmental impact (extracted from ISO 14001)

Any change to the environment, whether

adverse or beneficial, wholly or partially resulting from an organisation's environmental aspects.

## Industria 4.0

Industry 4.0 stems from the fourth industrial revolution, the process that will lead to fully automated and interconnected production. New digital technologies will have a profound impact in four areas of development: the first concerns data usage, computing power and connectivity, and includes big data, open data, Internet of Things, machine-to-machine and cloud computing for information centralisation and storage. The second is analytics: once the data is collected, it is necessary to draw value. The third line of development is the interaction between man and machine, involving the increasingly widespread "touch" interfaces and augmented reality. Finally, there is the whole sector that deals with the transition from digital to "real" and that includes additive manufacturing, 3D printing, robotics, communications, machine-to-machine interactions and new technologies to store and use energy in a targeted way, streamlining costs and optimising performance.

## Internet of Things

The Internet of Things is a set of technologies that allow you to connect any type of device to the Internet. The purpose of this type of solution is basically to monitor, control and transfer information and then carry out subsequent actions. The meaning of IoT is best illustrated with examples: IoT is, for example, a refrigerator that orders milk when it "notices" that it is empty. IoT is a house that turns on the heating as soon as it notices you arrive. These are examples of IoT, or objects that, connected to the network, allow you to combine the real and virtual world. The term IoT ("Internet of Things") was first used by Kevin Ashton, a researcher at MIT, Massachusetts Institute of Technology, where the standard for RFID and other sensors was found.

## ISO 14001

International Standard that identifies the requirements of an "environmental

management system” capable of identifying and assessing the environmental aspects of the activities, products and services of an organisation for the purposes of the continuous improvement of environmental performance and of the requirements of the system itself. The standard can be used for the purposes of obtaining certification as a third party, and/or for a self-declaration or simply as a guideline to establish, implement and improve an environmental management system.

### **ISO 14064**

Voluntary rules published by the International Organization for Standardisation (ISO), which define the international best practices in the management, reporting and checking of data and information relating to GreenHouse Gases (GHG).

### **ISO 9001**

International standard that defines the requirements of an organisation’s quality management system. This standard provides guidelines for improving the effectiveness and efficiency in the creation of a product or the provision of a service and for increasing customer satisfaction and loyalty.

### **Employee**

Individual who, pursuant to national laws or practices, is recognized as an employee of the organisation that draws up the report.

### **LCA (Life Cycle Assessment)**

Method of analysis that evaluates the combined interactions that a product/component has with the environment and defines its direct or indirect impact considering its entire life cycle: from production to recycling and final disposal.

### **Materiality**

Materiality is understood to mean the importance that a given (economic, managerial, social or environmental) topic has for the company and its stakeholders (see Stakeholders). Material

topics are aspects that reflect the significant economic, social and environmental impact of the organisation or influence substantially the assessments and decisions of stakeholders.

### **Omni-channel**

Omni-channel is a multi-channel sales strategy that seeks to provide customers with a seamless shopping experience, whether they are shopping online from desktop or mobile, over the phone or in a physical store. The multi-channel approach assumes that there is integration between distribution, promotion and communication channels in the backend. The omni-channel marketing strategy allows the customer to carry out the purchasing process through different physical and digital channels that are related to one another in order to offer an integrated and dynamic shopping experience. In omni-channel marketing the approach changes, with the simultaneous use by the customer of online and offline channels and the integrated strategic, operational and organisational management of the channels by the company, which enhances the physical and interpersonal benefits of stores, to which a more motivated consumer will be attracted.

### **Environmental policy**

#### **(extracted from ISO 14001)**

Overall intentions and direction of an organization related to its environmental performance as formally expressed by top management. The environmental policy provides a reference framework for conducting activities and defining environmental objectives and environmental goals.

### **ReACH (Registration, evaluation, Authorisation and Restriction of Chemical substances):**

European Community Regulation on chemicals and their safe use.

## Stakeholder and multistakeholder

Stakeholders are groups or individuals who, within reason, are expected to have significant interest in the activities, products and/or services of the organisation, or whose actions may affect the ability of the organisation to implement its strategies successfully and achieve its objectives. According to the AA1000SES standard (developed by the English organisation, AccountAbility, and recognised as an international benchmark), an organisation can assign a priority to its stakeholders or groups of stakeholders on the basis of their individual relevance. Relevance is an attribute determined by the combined evaluation of the dependency, influence and urgency that each stakeholder has with regard to the organisation or of other aspects which characterise the relationship between the stakeholder and the organisation. The multi-stakeholder approach envisages that a given topic be addressed with the participation and collaboration of players representing different interests in relation to the topic itself and who, therefore, have different demands. These can be, for example, the different players who contribute to a production chain, representatives of institutions, companies and non-profit organisations, etc.

## Scope

This defines the operational boundaries in relation to direct and indirect GHG emissions.

### Scope 1

This includes the direct GHG emissions of an organisation.

### Scope 2

This includes GHG emissions resulting from the production of electricity, heat or steam imported and consumed by the organisation.

### Scope 3

Includes indirect emissions other than those of Scope 2.

## Sustainability and Sustainable Development

The most widely used definition of sustainable development is found in the “Brundtland Report” of the World Commission on Environment and Development (named after the Chairman in office, Gro Harlem Brundtland), developed in 1987. Sustainable development is a model of development that “meets the needs of the present without compromising the ability of future generations to meet their own needs.” Sustainability is therefore an approach (towards the company, as well as towards business) that aims to ensure the balance between present and future demands, balancing economic-financial, social and environmental needs.

## Supply Chain

Process of planning, implementing and controlling the efficient and effective movement and storage of raw materials, semi-finished and finished products and related information from the point of origin to the point of consumption, with the aim of satisfying the needs of customers.

## Well-to-wheel

Analysis that concerns the entire life cycle of energy.

















## OMAL S.p.A.



Ph. +39 030 8900145 · Fax +39 030 8900143 · [info@omal.it](mailto:info@omal.it) · [www.omal.com](http://www.omal.com)

### HEADQUARTERS

Via Ponte Nuovo, 11 - 25050 Rodengo Saiano (BS) ITALY

#### Coordinates:

Lat: 45° 35' 53" North; Lon: 10° 05' 21" East

### PRODUCTION SITE

Via Brognolo, 12 - 25050 Passirano (BS) ITALY

#### Coordinates:

Lat: 45° 35' 51" North; Lon: 10° 05' 18" East