

INTEGRATED REPORT

2017 / 2018



**ENDANGERED
WILDLIFE TRUST**
Protecting forever, together.





Spectacular Shot

Our cover image, taken by Dr Antoine Marchal, is of an African Wild Dog, nicknamed Fabian. Fabian and his pack made history when the EWT reintroduced Wild Dogs into the northern Kruger National Park in July 2017, after a prolonged decline of Wild Dogs in the area. Fabian's tracking collar allowed the EWT to closely follow the movements of these endangered animals as they recolonised the northern KNP with Wild Dogs. Read more about this work on page 25–30.

CONTENTS

Message from the Chairman.....	1
A word from the CEO.....	3
Who we are.....	5
Snapshot of this report.....	6
The EWT Strategy.....	7
The EWT's Outlook.....	9
Programmes.....	13
Looking forward.....	93
The voice of the EWT.....	95
Funding our work.....	99
Our passionate people.....	102
Governance.....	107
Awards and achievements.....	115
Who we work with.....	116
Our supporters.....	117
Board of Management.....	121
Contact us.....	123
Where we work.....	124



The Endangered Wildlife Trust is a signatory to the United Nations Global Compact (UNGC)



The Endangered Wildlife Trust is a member of the International Union for Conservation of Nature



MESSAGE FROM THE CHAIRMAN

Conservation activities are needed now more than ever. But a raft of exponentially increasing commercial, political, operational and criminal obstacles continue to challenge a coordinated and cohesive approach of giving Mother Nature the cooperation she deserves from humankind to protect our most valuable asset: the planet. It is time that the people of this planet develop a more active conservation culture and make this voice heard by political and commercial leaders.

The EWT has played an active role during the past year to engage with the appropriate authorities and remains committed to continuing to play a leadership role in ensuring continuous active dialogue with all parties remains a key priority. Consensus on policy and the establishment of the required measures and controls to uphold the policy is an imperative for conservation efforts to have maximum impact.

I am pleased to report that the EWT has continued its rapid utilisation and early adoption of technological capabilities, within the context of an innovating world, to harness new tech for conservation efforts. A notable example is our now formally constituted and accredited drone capabilities. We have, to-date only touched the tip of this iceberg and we can expect much innovation and practical fieldwork enhancements emanating from this field of expertise. This capability will be offered to other organisations to assist in all conservation efforts.

It would be a telling figure if it was possible to account for all of the financial contributions which the corporate and NGO sectors channel into conservation each year. I am of the opinion that it would be surprisingly significant. The catalytic effect of these contributions is manifest in the strong partnerships forged between numerous organisations like the EWT, which turn money into great conservation impact. The EWT holds strong our belief in the power of partnerships, and puts this into operation on the ground through our many projects in partnership with fellow NGOs, government and the private sector across the sub-continent. Conservation requires continuous collective engagement and affirmation to maximise its effectiveness.

To this end, the EWT has taken an initiative to develop a Johannesburg-based Conservation Campus to house its operations in the future. The intention of the design and future build out is to be able to accommodate an environment of enhanced partnership by catering for the accommodation needs of other conservation initiatives and organisations. An education and training component for skills development and job creation in the "Green Economy". We look forward to reporting on this exciting initiative more in the year that follows. There is heightened economic pressure with South African

growth forecasts being reduced on a regular basis, which creates extreme challenges for the NGO sector, as corporate funding and contributions from the public become increasingly constrained. I wish to express my appreciation to the staff and Board of Trustees of the EWT for their extraordinary efforts over the period under review to ensure that the Trust continues to operate on a sound financial footing. The thanks on behalf the organisation goes out to all of our many loyal sponsors who continue to stand by us year after year – you have been the cornerstone on which the Trust is built. I am grateful to welcome those individuals and organisations who have recently aligned with us. Your generosity and pledges of future financial support are a great comfort, knowing we have your backing to continue with projects so vital to our country.

A special word of thanks to my colleagues on the Board for their selfless contributions to ensure we continue to maintain the highest standards of corporate governance, sound operational management and performance measures.

To those who share our vision, which is to be discovered and understood by reading this integrated report, your passion and support is the fuel of a sustainable tomorrow.

#cooltoconserve



Dirk Ackerman
Chairman of the Board



A WORD FROM THE CEO

From the CEO's Desk: Reflections on 2017/8

The illegal wildlife trade is nothing new, and has appeared among some of humanity's worst traits for centuries. In 2017 and 2018, this issue featured more strongly in the rhetoric of politicians, global media, and the public, as we began to face the very real possibility of losing a number of species if serious action is not taken.

Human beings have been trading for around 300,000 years. Evidence from Middle Stone Age sites in southern Kenya suggests that hominins were exchanging goods with others, as weapons uncovered at these sites are made of materials not locally found. The ancient Grecians had Hermes as their god of trade and the Roman god Mercurius was their god of merchants. Given the human propensity for breaking laws as soon as they are established, one can assume that human beings have also been trading illegally for as long as there have been laws to regulate trade. So why the increasing fuss around Illegal Wildlife Trade? It is not a new issue and rather, is one that conservationists have been grappling with for decades.

So what has changed? On the upside, many countries and cultures that previously engaged in enormous volumes of wildlife trade have decreased their consumptive use of wildlife. In several countries, there is a strong awareness that many wildlife species cannot sustain large volumes of trade; that the trade is often cruel and unethical; and that better alternatives for their uses (fashion, medicinals, and so on) are available for less money. In some cultures, the use and trade in wildlife has even become stigmatised. On the downside, the consumption of wildlife and their products has increased in many parts of the world, due to increasing wealth, popular beliefs, financial speculation and 'investment', and ease of access to illicit markets. Coupled with the decline in many species and the associated increasing value of their body parts; the free flow of illicit goods via established black markets; the ease of access for buyers and sellers to social networks and the "Dark Web"; the escalation in corruption globally, and its impact on law enforcement; and the dynamic nature of illicit trade flows, it is little wonder that several species now face a very real extinction risk. Or may already have succumbed. South Africa has, although not many people know this, already lost three cycad species to illegal trade in the past decade and several others face a similar future.

Around 100 elephants and three rhinos are poached every day across our continent. One need only do the maths to estimate how long populations of around 415,000 elephants and 29,000 rhinos will persist. Much has been said about various solutions and those that are attached to their favourite solution will

go to great lengths to slate alternative options. But before we can propose conservation-oriented solutions, we need to consider a few contributing factors, most of which have nothing whatsoever to do with the conservation sector or even what we do or say.

1. There are more than 7.6 billion people on the planet. This is roughly double the number of people alive in 1970. There are too many sensitivities around talking about the human population. One has to tread carefully and politicians, religious leaders, and social activists shy away from risking their futures to ever suggest that there are too many of us. Sociologists believe that there are not in fact too many humans, and many technocentrists believe that with enough clever technology, billions more of us could still eat, drink, and live meaningful lives. This is simply not rational. With more and more people, there is less quality education for all, fewer jobs, less space for housing, and less materials for building. Less food, less water, less cheap mass transport solutions, and simply put: less space. There is more competition for resources, more urbanisation, more pressure on the planet, and more demand for finite resources that simply cannot sustain the energy demands of an exploding human race. Human beings have been successful in reducing infant mortality by over 15% in the last decade, and extending human lives by almost double in the last two centuries. This domination of human life over other species has come at a great cost to almost all other forms of life on the planet, most of which are in sharp decline. There are too many of us and this has to be addressed if the conservation of any other lifeform is to be successful.

2. We are selfish. Human beings need to justify the existence and persistence of almost every other lifeform on Earth in terms of what it can do for us. We have coined phrases like "if it pays it stays" and we need to motivate our conservation actions or expenditures in terms of why it is important for human life, wellbeing and prosperity. In 2017, the donations made by Americans to charities supporting animal or environmental causes was only 3% of total giving, and in the UK this jumped to only 8%. We only like to support ourselves and what our money can do for our species. It is this same selfish gene that drives the illicit wildlife trade by either the consumer, the trader or the poacher. It is the same selfish gene that drives many of the users of wildlife products, from fashion to claims of increased virility, strength and power.

3. Education is often cited as the solution. Billions in donor funding is poured into environmental education under the belief that if we teach children to conserve our wildlife, they

will change the fate of doomed species in the future. Despite decades of environmental education taking place in the classrooms of private and public schools, from urban centres to rural outposts, the future of our wildlife has never been more bleak. We forget that children become adult humans. They become wealthy and desire more, or they become poorer and have fewer choices. For the rural poor, it is possibly better to invest in education programmes that focus on science, maths and literacy. To equip young people to become employed, economically active, and have options. Evidence has shown that when people are gainfully employed, they make better life decisions, they have smaller family sizes, and they invest and participate in charitable and social causes. Teach our kids but teach them the skills and tools to become future leaders. Get them employed, help them to break the cycle.

4. After human population, the next taboo for conservationists is corruption. We live in a world where almost everyone is either engaged in, or confronted by, corruption on a daily basis. Corruption spreads, and like a virus, it adapts, infects and destroys systems. It leads to social decay and moral depression. It erodes border controls, and feeds off greed. It is ignited by the selfish-gene and resists simple remedies. And yet it is the single biggest factor in the fight to stamp out the illicit wildlife trade that thrives in a system of corrupt rangers, game ranchers, border control agents, policeman, judges and magistrates, politicians, retailers, consumers and many other who are "hiding in plain sight". An entire chain of corrupt individuals and actions can render the very good work done by several good people holding the very same positions in society, useless. In this numbers game, the work of several good people can unravel with the action of just one corrupt individual. It takes a chain of people ALL doing the right thing to make a law effective and a system work. And the conservation sector is just one link in this chain.

But the links CAN be fixed and the chain CAN work, when we form cross-sectoral partnerships that work to address the weak links. The EWT has long recognised that we have to address all the weaknesses in the system, even if we only do this one baby step at a time. The EWT has embraced the concept of Population, Health and the Environment (PHE) to address human population and sustainable family sizes. We work with the Department of Health and our partners working on human health and sexual rights. We support several projects that address the broader educational standards in schools in the communities in which we work; and we work with partners who address literacy levels, adult education, and skills development for unemployed people. We work with law

enforcement agencies to enhance skills for fighting crime and we support those champions in the criminal justice system to work collaboratively, effectively and with increased knowledge. The EWT's 2017/8 Integrated Report is filled with reports on how our passionate staff, friends, and partners have achieved positive gains with measurable impact, across a diversity of species, habitats and issues. We are continually expanding our partnerships to embrace all the challenges facing the future of wildlife on this continent. And we have done this well. The report highlights many exciting successes and remarkable achievements. The Trust delivers on our promises and we are a solid investment option for the generous sponsors who choose the EWT as their partner to deliver on their passion for protecting our African wildlife.

Despite 2017/8 being a year that challenged and tested us, the EWT has achieved some remarkable conservation gains. I am proud and blessed to work alongside some of the continent's most passionate, committed and talented people, both within the EWT staff as well as in our Trustee Body. I learn from you all every day and I am inspired by your energy and love for our Africa. To the partners and donors who choose the EWT – thank you.



Yolán Friedmann
Chief Executive Officer

A handwritten signature in black ink, appearing to read 'Yolán Friedmann', written over a light-colored background.

WHO WE ARE

The EWT is a non-governmental, non-profit, conservation organisation, founded in 1973 and operating throughout Southern and East Africa. We conserve threatened species and ecosystems by initiating research and conservation action programmes; implementing projects which mitigate threats facing species diversity; and supporting sustainable natural resource management.

The EWT communicates the principles of sustainable living through awareness programmes to the broadest possible constituency for the benefit of the region. We have developed a unique operational structure through which our mission and objectives are achieved – meeting our conservation goals through the work of specialist, thematic programmes, designed to maximise effectiveness in the field and enhance the development of skills and capacity.

These programmes form the backbone of the organisation and are essentially self-managed projects harnessing the talent and enthusiasm of a dynamic network of individuals

who specialise in an area of conservation importance and have developed unique expertise in response to the challenges they face. Programmes comprise multiple stakeholders and harness their diverse but relevant expertise to address environmental priorities. Stakeholders include national and provincial government, other NGOs, landowners, local communities, farm workers, conservancies, academic institutions and industry. The EWT also acts as a public watchdog, often taking government and industry to task for decision-making that does not meet sustainability criteria.

Our Vision

A healthy planet and an equitable world that values and sustains the diversity of all life.

Our Mission

The Endangered Wildlife Trust is dedicated to conserving threatened species and ecosystems in Southern Africa for the benefit of all people.



Malawi Cheetah reintroduction. Photo credit Olivia Sievert

SNAPSHOT OF THIS REPORT

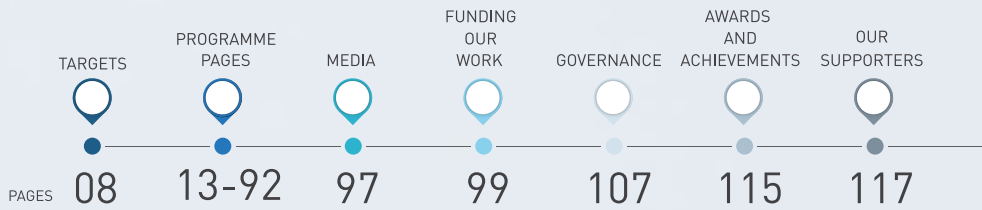

THE EWT STRATEGY

The EWT Strategy: impact-driven conservation

Our strategic approach

The EWT's conservation strategy has, for the past decade, centred around six Strategic Imperatives, which encompassed the broad spectrum of the programmatic work of the EWT. We convened a strategic planning workshop in March 2012 to update the strategy, leading to the development of the EWT Conservation Strategy 2012–2017, which set targets and measurable indicators for all of the EWT's programmes. For the first time, the Trust was able to measure conservation impact across the entire organisation.

In July 2017, the EWT's management convened another workshop to chart the direction of the organisation for the period leading up to the EWT's fiftieth birthday, in 2023. A team from IQ Business – including the CEO, Adam Craker – facilitated the workshop and we are grateful to them for their assistance in this important process. In the EWT Strategy 2018–2023 we have refined our Strategic Imperatives for the next five years, reducing the original six down to three key pillars of conservation impact: Saving Species, Saving Habitats, and Benefiting People. These three Strategic Imperatives are actioned through ten High-level Goals, supported by 11 Cross-Cutting Approaches.

Progress against our strategy

Following the strategy workshop, our 13 conservation programmes each developed a set of objectives to refine the scope of their work and provide a roadmap for achieving their desired conservation impact. For the period under review, we achieved anticipated progress in 78% of the 54 programme objectives that we planned for implementation during this reporting period. We achieved our greatest progress for objectives under Strategic Imperative 1 (83% on track), and performance was lowest in the work under Strategic Imperative 2 (71% on track). The slightly poorer performance against Strategic Imperative 2 can be attributed to unanticipated delays in securing protection for sites, largely as a result of protracted engagement with government agencies.

This is the fifth reporting year in which we have been able to monitor overall progress towards targets/objectives, allowing us to monitor trends in performance as an organisation. We have been increasingly successful in meeting our desired programmatic impact over the past five years.

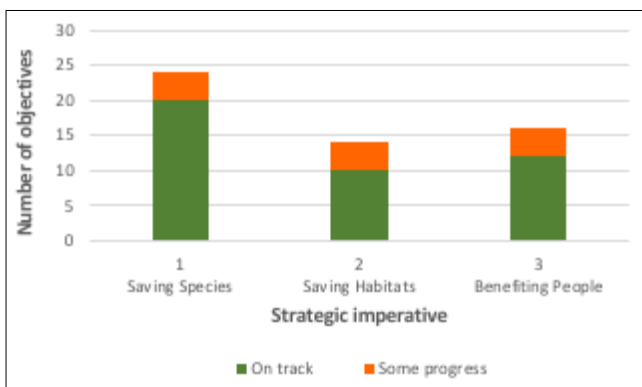

The number of planned programme objectives that were on track or made some progress in 2017/2018, for each of our three Strategic Imperatives.

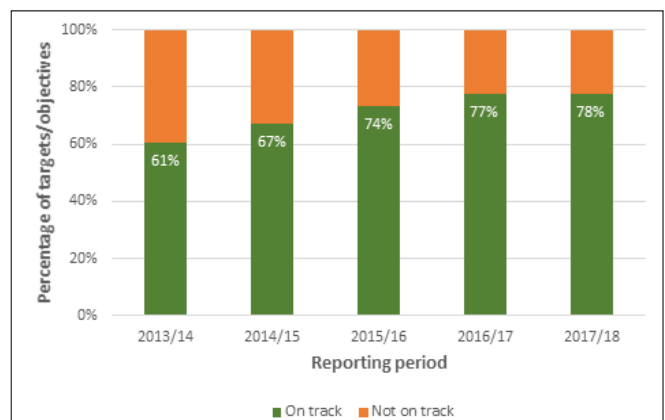

Annual progress towards achieving our programmatic targets/objectives between 2013 and 2018. Percentages indicate the number of planned targets/objectives deemed “on track” at the end of each reporting cycle.

EWT Strategic Imperatives: Some facts and figures from 2017/18

1

STRATEGIC IMPERATIVE 1: Take action to conserve threatened wildlife.

- Our KwaZulu-Natal aerial survey continues to show increasing populations of all three of South Africa's crane species in the province, with total counts of 2,981 Grey Crowned Cranes, 313 Wattled Cranes and 1,216 Blue Cranes. See page 15.
- This year, with a team of 52 people, we conducted a rapid survey (bioblitz) of the biodiversity of Rugezi Marsh, Rwanda, recording 123 bird species, 13 mammal species, 13 amphibian species and four reptile species in the process. See page 18.
- We significantly increased Wild Dog safe space by 70%, through reintroductions to Gorongosa (Mozambique), Maremani (Limpopo, South Africa) and northern Kruger National Park. We increased Cheetah safe space by 2%. See page 28.
- We have trained 122 individuals as part of our Poisoning Intervention and Prevention programme, within known vulture poisoning hotspots in the Lowveld, Mpumalanga, and northern Zululand, KwaZulu-Natal. See page 25.
- This year we placed 11 livestock guardian dogs in rural communities, and six with commercial farmers, and no livestock losses were recorded in the past year as a result of these placements. See page 30.
- We helped fund training of 11 detection rats to detect pangolins and the rosewood – two species rampant in the illegal wildlife trade market. See page 90.
- We celebrated International Vulture Awareness Day (IVAD) for the ninth time since we initiated this global event in 2009, on 2 September 2017. This year, 32 countries and 138 organisations registered their activities on the IVAD website. See page 75.
- We completed the publication of all 331 assessments for the Mammal Red List of South Africa, Lesotho and Swaziland. See page 34.

2

STRATEGIC IMPERATIVE 2: Uphold ecosystem integrity and conserve threatened habitats.

- We cleared alien invasive plants and rehabilitated 610 ha of wetland and coastal habitat in KwaZulu-Natal at Pickersgill's Reed Frog sites, employing 71 local community members. See page 60.
- We cleared 417 ha of *Mimosa pigra* – an invasive alien – from the Kafue Flats in Zambia. See page 16.
- We are currently negotiating Biodiversity Stewardship agreements for >100,000 ha of threatened grassland habitat and key catchments. See page 19.
- We surveyed 500 quadrants for species, cover and cover per species as part of riparian habitat condition assessments in the Karoo. See page 39.
- We purchased the 1,400 ha Medike Nature Reserve in the heart of the western Soutpansberg, in the Sand River gorge, a core site for catalysing our Soutpansberg Protected Area Project. See page 54.
- We launched an ambitious five-year project aimed at promoting and embedding sustainable land management in the Karoo agricultural landscape. See page 38.

3

STRATEGIC IMPERATIVE 3: Enable biodiversity-friendly businesses, enterprises and livelihoods.

- We initiated an innovative Wild Dog-based ecotourism model, taking more than 120 visitors in the Waterberg to view the last free-roaming Wild Dog pack in South Africa, during the 2018 denning season. See page 30.
- We delivered six training courses to our three toll concessionaire companies (Bakwena N1N14 Toll, TRAC N4 and N3 Toll Concession), supporting 75 staff to better monitor and prevent wildlife-vehicle collisions. See page 86.
- We initiated the Biodiversity Disclosure Project to enable businesses to disclose their biodiversity performance in a standardised and comparable manner. See page 45.
- Our innovative strategy led to Eskom proactively mitigating 334 power line spans (approximately 149 km) to reduce bird collisions and electrocutions throughout South Africa. See page 80.
- Our WESSA Eco-Schools programme presently benefits more than 10,200 learners and over 300 teachers, as well as countless parents and other community members. See page 70.
- We introduced our "Cranes in the Classroom" learning series to more than 15 schools in our project sites through South Africa, and rolled it out to over 300 learners from Grades 1–6. See page 14.
- We provided beekeeping training and skills development to more than 30 rural beekeepers in the southern Drakensberg through the Healthy Catchment Alliance. See page 50.
- We distributed 100,000 fodder seedlings to 449 beneficiaries within eight cooperatives in the Burera District of Rugezi Marsh, Rwanda, as part of a livelihood project. See page 18.
- Through our partnership with Pathfinder International, we have addressed the self-identified need of over 33,000 rural community members for access to improved reproductive healthcare and "Future Planning" in the Marico River catchment, North West Province. See page 51.

EWT OUTLOOK

OPPORTUNITIES

Expanding our reach

There are numerous opportunities for us to amplify our conservation work into new thematic areas and additional geographic sites. By working with different sectors – including the health, agricultural and energy sectors – we can enhance and replicate our programmes and projects, to unlock greater impacts across southern and East Africa.

Changing land tenure

We recognise that land reform, if undertaken in a legal and structured manner, will allow for new relationships between the EWT, individuals and communities, opening diverse conservation opportunities for species.

Leveraging external and internal partnerships

Increased cross-sectoral collaboration and knowledge exchange between scientific, civil society, government and community actors can vastly improve our likelihood of achieving sustainable conservation outcomes in the long term.

Harnessing best conservation practice

The updated EWT Strategy, and the organisation-wide adoption of the Open Standards for the Practice of Conservation (a set of best practices to help teams be systematic about planning – see page 34), will improve our ability to think critically about our work, paving the way for increasingly robust approaches that we constantly monitor, evaluate and adapt for effective impact.

GROWTH AREAS

Adopting the latest technology

By using state-of-the-art technology – from the latest forensic techniques, to interactive digital applications, to conservation monitoring equipment and the analytical platforms to interpret data, to systems that improve our operational performance – we will ensure that we remain relevant and effective in a rapidly changing world.

Underscoring the links between health, people and healthy ecosystems

We aim to ramp up our current work to integrate human population health and wellbeing considerations into our conservation programmes, working with health-sector partners to address unmet family planning needs among the communities in our priority conservation landscapes where we work.

Promoting community development

The EWT recognises the critical importance of sustainable socio-economic development and we will continue to establish and maintain partnerships to unlock opportunities through the green economy (and wildlife economy) to improve people's livelihoods wherever we work. Our recent land purchase in the Soutpansberg (see page 54) will provide one important hub from which to promote sustainable eco-businesses that benefit society.

Remaining relevant

The EWT is excited about ramping up its contributions to national and international targets. Our significant contributions towards achieving the Sustainable Development Goals, and the Aichi Targets of the Convention on Biological Diversity, underscore our relevance to both governments and corporates.

CHALLENGES

Addressing internal skills and capacity gaps

Careful attention is required to ensure that our internal capacity and skills are able to keep up with the EWT's broadening scope and expanding geographic area of operation. It is increasingly difficult to fund the back-end services that we require to ensure top-quality governance support and administrative backup, as many donors are hesitant to pay for this. Skills retention among our support service departments is also difficult as we compete for these skills with corporates who can offer better remuneration.

Making the case among diverse audiences

To meet our ambitious conservation targets we need to secure the buy-in and cooperation of a wide range of role-players – from business and government actors, to protected area managers and communities – and this will require skilful engagement and creative persuasion.

Addressing escalating threats

Operating in an environment where threats from infrastructure development, mining, agricultural expansion and human disturbance are continually intensifying, and where short-term political agendas may be counter to environmental sustainability, requires unrelenting energy, innovation and optimism. Rising levels of unemployment, poor education, and political instability, are exacerbated by a rapidly increasing human population – which is expected to double in sub-Saharan Africa by 2050 – making these socio-economic challenges very tough to address.

Increasing commodification of wildlife

The increasingly intensive production of wildlife for commercial purposes – examples include breeding Lions for their bones, and keeping rare colour variants in small camps – undermines the conservation of free-ranging wildlife and large natural wildlife areas and threatens to erode South Africa's reputation as a conservation leader.

Ensuring sustainability in a changing political and economic climate

South Africa's economic climate remains unsettled, as witnessed through the country's governance and declining economic outlook. This has increased competition for funds, reduced access to unrestricted income, and public support through donations is declining drastically. This puts pressure on us to look offshore but globally, South Africa is seen as uncertain and a risky place for investment. Leading up to elections in 2019, the policy environment is unlikely to send strong messages of stability, and this does not bode well for funding and investment. The Trust needs to be diligent in remaining relevant and securing funding against this harsh economic backdrop.

RISKS

National land reform political discourse

The discourse around South Africa's land reform policies is creating uncertainty and fear, frightening away investors, increasing emigration and threatening the Biodiversity Stewardship process. The EWT's Strategic Imperative 2 relies heavily on cooperation from current and future landowners. There is currently a reluctance by some landowners to engage on land-related issues, with land value decreasing rapidly, until issues around land expropriation without compensation and the state of current land claims are resolved.

The impact of declining funding streams

While the EWT deliberately maintains a mixed approach to funding – including through individual donations, trusts and corporates, the large financial contributions from major international donors have an important impact on our year-to-year income streams. While these projects are critical to our work, we need to maintain focus on all our funding streams in order to maintain a steady and increasing income year on year.

SUSTAINABLE DEVELOPMENT GOALS

In September 2015, 193 countries around the globe adopted a set of goals to end poverty, protect the planet, and ensure prosperity for all as part of a new sustainable development agenda. Each goal has specific targets to be achieved over the next 15 years. Our efforts to address specific goals are illustrated on the following programme pages, using the icons listed below.



**SUSTAINABLE
DEVELOPMENT**

GOALS



AICHI BIODIVERSITY TARGETS

In October 2010, the 10th meeting of the Conference of the Parties to the Convention on Biological Diversity (CBD) adopted a revised and updated Strategic Plan for Biodiversity, including the Aichi Biodiversity Targets for 2011–2020. As a signatory to the CBD, South Africa is committed to meeting these 20 targets, and the EWT plays a significant role in supporting this. Our efforts to address specific targets are illustrated on the following programme pages, using the icons listed below.



Awareness increased



Biodiversity values increased



Incentives reformed



Sustainable consumption and production



Habitat loss halved or reduced



Sustainable management of marine living resources



Sustainable agriculture, aquaculture and forestry



Pollution reduced



Invasive alien species prevented and controlled



Pressures on vulnerable ecosystems reduced



Protected areas increased and improved



Extinction prevented



Genetic diversity maintained



Ecosystems and essential services safeguarded



Ecosystems restored and resilience enhanced



Nagoya Protocol in force and operational



NBSAPs adopted as policy instrument



Traditional knowledge respected



Knowledge improved, shared and applied



Financial resources from all sources increased



AFRICAN CRANE

CONSERVATION PROGRAMME



A pair of Grey Crowned Cranes

Crane conservation takes flight

Africa's four crane species are all threatened and thus, they are ambassadors for the conservation of catchments containing wetland and grassland ecosystems that also provide humans with essential goods and services. Their iconic and charismatic nature appeals to the public and creates a doorway for collaborative conservation.

Working in partnership with the International Crane Foundation (ICF), the African Crane Conservation Programme's goal is to secure and improve the conservation status of Africa's four resident crane species by reducing threats to their wetland and grassland habitats.

We achieve this by working closely with local communities and key stakeholders to empower individuals, community groups

and organisations to manage catchments for the benefit of both people and cranes; and ensuring that conservation is mainstreamed into local decision-making and practices for sustainable conservation impacts.

The ACCP contributes to all three of the EWT Strategic Imperatives through a team of 22 staff and eight partner organisations working across East and Southern Africa. Our conservation action focusses on improving our understanding of cranes, the threats they face, and the threatened wetland systems on which they depend. We work closely with local communities and key stakeholders in finding solutions that benefit both cranes and people on the same land.



Wattled Crane

South Africa: bringing cranes to the classroom

If we cannot take children to cranes, then we bring cranes straight into their classrooms. Our “Cranes in the Classroom” learning series was developed by one of our partners in South Africa, the KwaZulu–Natal Crane Foundation and, thanks to their help, our team has been trained in the roll–out of the series. This learning series aims to encourage learners to use critical and creative thinking, work effectively as individuals and members of a team, communicate effectively, show responsibility towards the environment and the health of others, and demonstrate an understanding of their world as an integrated and complex system.

The lessons in the “Cranes in the Classroom” learning series support and supplement the South African education system, and the Curriculum and Assessment Policy Statement, ensuring that schools buy in and support it. In January 2018, we introduced the learning series to over 15 schools throughout South Africa, and rolled it out to over 300 learners from Grades 1–6. The programme focusses on conserving the three crane species found in South Africa, protecting our fresh water and wetland resources, guarding our vulnerable grasslands, and providing valuable life lessons.

South Africa: ecosystem goods and services – what is our environment telling us?

We embarked on a journey in July 2017 to develop an easy to use, citizen science based, Ecosystem Goods and Services Monitoring Toolkit. Ecosystem goods and services (EGS) are the benefits arising from Mother Nature – these include for example, water provisioning, the prevention of flooding, food, soil protection and more. The purpose of our EGS Monitoring Toolkit is to measure change in environmental goods and services derived from a farm or collective of farms. Understanding the delivery of ecosystem goods and services and working towards improving these, is essential to guiding management, restoration and protection of ecosystems. Through this project, we investigated solutions that capacitate local stakeholders, such as farmers, to assess the state of their environment.

This will enable local governance systems to take action in addressing environmental degradation within the area. The EGS Monitoring Toolkit focusses on monitoring services – including erosion prevention, water quality (purification), water security/ base flow, infiltration, and biodiversity – to determine changes in the quality of each service from a land unit over time. We used the toolkit at five sites across our Drakensberg project area this past year, including on both commercial farms and communal rangelands, training over 150 people in the process. We are building up a picture of the landscape’s ability to deliver these services, while we have seen a significant improvement in people’s understanding of how the environment supports life and economic development through the services supplied by our natural ecosystems – our ecological infrastructure.



Africa: aerial surveys and satellite tracking – a glimpse into the world of cranes

This year we completed three aerial surveys of cranes, including the 24th consecutive count of cranes in KwaZulu–Natal, and the first ever aerial surveys in both Rwanda and Angola.

We were fortunate to conduct the first-ever wildlife survey of the Zambezi River headwaters, the Buluzi Plain, in Angola. Our survey team discovered three new populations of Wattled Cranes (*Bugeranus carunculatus*) here, including two breeding grounds. Especially exciting, one of the breeding grounds is contiguous with the Liuwa Plains National Park of Zambia, where we have been working for several years – highlighting an excellent opportunity for a transboundary Ramsar “Wetland of International Importance” or extended protected area. We aim to follow up next year with targeted surveys, yielding numbers and distribution, of these newly discovered Wattled Crane breeding grounds.

In another first, we worked with colleagues from the Rwanda Wildlife Conservation Association to conduct an extensive coordinated aerial and ground count for Grey Crowned Cranes (*Balearica regulorum*) in Rwanda. The minimum count of 487 Grey Crowned Cranes is in line with expected estimates of 500 Grey Crowned Cranes left in Rwanda. The survey assisted in identifying key sites for conservation action, including current priority sites, and additional wetland areas we should consider in the future.

Our KwaZulu–Natal aerial survey continues to show increasing populations of all three of South Africa’s crane species in the province, with total counts of 2,981 Grey Crowned Cranes, 313 Wattled Cranes and 1,216 Blue Cranes (*Anthropoides paradiseus*). In South Africa, we fitted five satellite trackers to

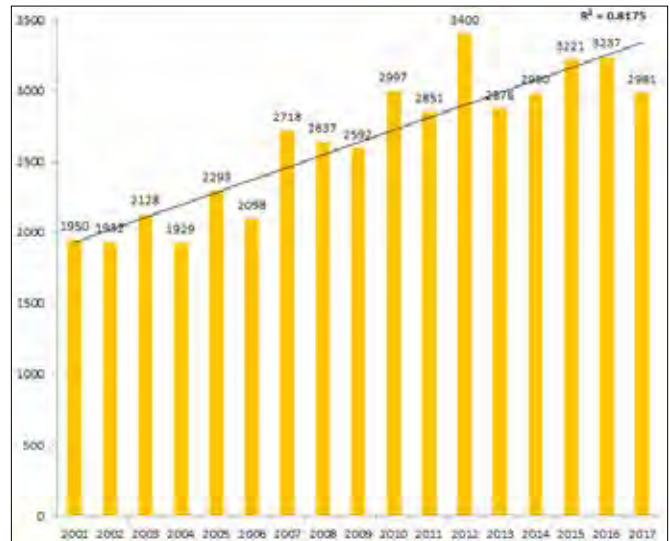

Numbers of Grey Crowned Cranes counted during the aerial survey over the past 16 years.

Wattled Cranes, in partnership with the KZN Crane Foundation and the University of KwaZulu–Natal. For the first time we can document accurately the movements of breeding Wattled Cranes and determine their home range sizes. We also documented the seasonal migration of non-breeding Wattled Cranes between the central KwaZulu–Natal Midlands in November to the southern Drakensberg region of Cedarville and Matatiele, returning the following April. This migration takes just two days with an overnight stop usually around Swartberg.



Wattled Crane

Zambia: establishing a crane population estimate for Liuwa Plains National Park

Between July 2017 and May 2018, we conducted nine surveys (eight ground and one aerial) for Wattled and Grey Crowned Cranes in the Liuwa Plains National Park and surrounding Game Management Area, together with African Parks and the Zambian Carnivore Programme. Our results clearly showed that crane numbers are highest during the wet summer months and lowest in the winter dry season. In May 2018, at the end of the wet season, we counted 730 Wattled Cranes in our aerial survey – the most recorded – including 90 breeding pairs and 52 in families. We recorded the highest Grey Crowned Crane numbers in October 2017, counting 544 individuals. Both species are faring well in this area and their populations appear to be stable. We concluded the area has a globally significant population of both species and, excitingly, holds around 9% of the global population of Wattled Cranes.

We also identified disturbance caused by the fishing communities as a key threat to cranes; these fishers have legal access to the pans throughout the park during the fishing season. Their presence prompts cranes to leave the area with their chicks to forage in the surrounding landscape, where they are more exposed to predators, while suitable food is more limited. This threat could be easily managed through timing of the allocation of permits to the fishing community. A second impact on populations comes through the loss of eggs caused by large herds of antelopes such as wildebeest and zebras that move into the pans for water. Our research and conservation work is now feeding back into conservation management decisions of the park, through the incorporation of our data into the management and land use planning process, and will provide key conservation support to the two crane species and their habitats.



ACCP team members monitoring nests



Zambia: securing the Kafue Flats

The Kafue Flats, a rich mosaic of lush floodplain grasslands in Central Zambia, is one of the important areas in sub-Saharan Africa for the conservation of Wattled Cranes. However, the spread of the invasive alien plant, *Mimosa pigra*, on the Kafue Flats has had severe consequences for biodiversity, taking away valuable habitat for the Wattled Cranes and other wildlife that depend on these floodplain grasslands.

This year we launched a project aimed at removing up to 90% of the estimated 3,000 ha *Mimosa* infestation in Lochinvar National Park, on the Flats and its surrounds. This large-scale project involves a highly intensive control effort with substantial community involvement. Our project also ensures that the

Zambian Department of National Parks and Wildlife has the capacity and commitment to the long-term monitoring and small-scale *Mimosa* eradication efforts needed to retain project gains. We employed 150 field workers from the surrounding local communities to physically remove the *Mimosa*. Starting in November 2017, we had cleared 417 ha of *Mimosa* by mid-January 2018. We envisage that this strategy will contain *Mimosa* and prevent it from spreading further into uninvaded parts of the floodplain. In future, our integrated *Mimosa* eradication plan will introduce chemical and biological control methods, and a permit has already been issued to import the biological control agent for *Mimosa*.





Building our team and ensuring conservation impact in East Africa

In February and March 2018, members of the African Crane Conservation Programme and Erica Cochrane, Conservation Measures Manager of the International Crane Foundation, met in Uganda and Rwanda for a nine-day retreat. The retreat focused on team building and improving the effectiveness of our work in East Africa through a combination of conservation planning and new crane and ecosystem monitoring techniques. We devoted roughly half of the retreat to learning concepts behind the Open Standards for the Practice of Conservation, a set of best practices for instigating evidence-based conservation and adaptive management, and developing stronger strategic plans. The other half of the retreat was devoted to learning new crane and ecosystem monitoring techniques to track the impacts of our interventions on crane status and wetland health over time.



South Western Uganda: an extension of the Crane Custodian programme

Crane Custodians are essentially local community champions who increase awareness of cranes and their habitats amongst their own communities, and actively reduce threats to cranes where possible. We piloted this approach in southwestern Uganda over the last few years. At this early stage, it seems that crane pairs that are protected by Crane Custodians breed better. Certainly, we realised improved breeding success during the 2017/18 breeding season, where all pairs that were raising chicks under the surveillance of Crane Custodians, fledged two chicks.

At our strategic workshop in February/March 2018, we strengthened the process towards our goal of increasing Grey Crowned Crane numbers in each project area, while increasing our local team's understanding of and buy-in into the strategy. We now have a clear understanding of the impacts or outcomes we hope to achieve through Crane Custodians and the activities required to reach that goal. To this end, we increased our Crane Custodians in the Kabale Wetlands region of southwestern Uganda to nine. They underwent training in identifying cranes, reducing the threat of disturbance to cranes, community outreach programmes, crane monitoring, engaging local leadership in crane conservation activities, and ensuring enhanced crane breeding success. Through this strategy, we intend to reduce direct threats to cranes and their wetland habitats and to increase the sense of ownership and stewardship of communities to cranes.



Rwanda: Rugezi Marsh bioblitz and community livelihood development

Our project at the Rugezi Marsh, a 7,000 ha Ramsar Wetland Site of international importance, entered its seventh year of operation. With more than 300,000 people in its catchment, we need to work with local communities to enhance livelihoods that either reduce threats, or add to the value placed on the marsh. This year, with a team of 52 people, we conducted a rapid survey (bioblitz) of Rugezi's biodiversity, recording 123 bird species, 13 mammal species, 13 amphibian species and four reptile species in the process. We hope that this information – including seven species from the aforementioned classes classified as threatened on the IUCN Red List – will form the baseline of a strategy aimed at securing the marsh as a protected area in the country.

We continued with two livelihood projects, both of which are underpinned by conservation agreements signed by the local community and local authorities. These are negotiated voluntary agreements with relevant partners, which outline the benefits these communities will receive in return for conservation action. First, we have worked with local beekeeping cooperatives over the last 3–4 years, facilitating this livelihood, as beekeepers previously started illegal wild fires in the marsh to smoke bees out of traditional hives. In February 2018, we initiated fodder production as a second livelihood option, informed by an acute lack of pastures/fodder, which limited opportunities for livestock production in the fringes of Rugezi Marsh. This livelihood project supports community groups involved in livestock production. Until now, they have been relying on Rugezi Marsh for fodder – either through direct grazing or through grass harvesting – despite its zero-grazing policy. Our project aims to build the capacity of community members in fodder production to reduce pressure on the marsh. To-date, we have selected and interacted with 549 beneficiaries from eight cooperatives in Burera District to explain to them the operations and benefits of the fodder project, distributing 100,000 seedlings to 449 beneficiaries.



Western Kenya: networks and improving livelihoods

At a strategic level, we helped establish a Kenya Crane Conservation Forum. This is a multi-stakeholder platform that brings together over 40 stakeholders from the private sector, government agencies, civil society organisations, journalists, institutions of higher learning and local communities, for networking, sharing information, and advocacy towards collective action that reduces threats to and promotes crane and wetland conservation in Kenya.

In western Kenya, we have improved livelihoods in a number of ways, including distributing 20 dairy goats to families around Kingwal and Saiwa wetlands, and in order to scale up, the first kids produced will be given to other local community members. We have maintained the indigenous tree nursery at Kipsaina, and have distributed over 10,000 indigenous tree seedlings to restore riverine habitats. With time, excess trees will be felled and used for local community projects, such as for the production of chairs and tables in local schools. Two water springs were protected in Kingwal and Tulon, providing a source of clean water for the first time ever to local communities, and reducing cases of waterborne diseases since this project was established. In return for these benefits, local communities have committed to monitoring cranes, protecting them during the breeding season, and mitigating threats, where relevant and possible.



**ENDANGERED
WILDLIFE TRUST**
Protecting forever, together.

In
partnership
with





20 dairy goats

distributed to families in
Western Kenya



417 ha

Mimosa pigra
cleared from the
Kafue Flats in
Zambia



730

Wattled Cranes &
554

Grey Crowned Cranes
counted in Liuwa
Plains National Park
and surrounds in Zambia



Grey Crowned Crane
numbers in South
Africa have increased
by over **40%** in the past
15 years – the only
increasing population
of Grey Crowned
Cranes in Africa



Over 100,000 ha

of grasslands and wetlands legally
protected from unsustainable
development for the next 30 years

What our stakeholders are saying

“Ever since I was given these goats to take care of, my life is not the same again. Goat milk has improved the health of my kids and they don’t catch the common cold and flu as had been before. The Conservation Agreement training was also a nice exposure for me as it has helped me to engage other farmers and tell them the importance of being a crane custodian and conserving the wetlands.” – Evaline Namarome, a beneficiary of dairy goat livelihood project and one of our model farmers.

AFRICAN CRANE CONSERVATION PROGRAMME TEAM



Kerryn Morrison
ICF/EWT Senior Manager:
Africa



Tanya Smith
Southern Africa Regional
Manager



Cynthia Chigangaidze
Senior Administrator



Matthew Becker
Programme Officer



Janine Rennie
Southern Drakensberg
Region Field Officer



Steven Segang
Highveld Community
Projects Officer



Thabo Madlala
Field Officer



Griffin Shanungu
Zambia Country Coordinator



Adalbert Aine-omucunguzi
East African Regional
Manager



Jimmy Muheebwa
Uganda Projects Coordinator



Rudolf Makhanu
Kenya Country Coordinator



Maurice Wanjala
Kipsaina Crane and Wetlands
Conservation Group, Kenya



Olivier Ngabonziza
Project Assistant, Rugezi
Marsh, Rwanda



Daniel Munana
Rwanda Field Coordinator



Rukundo Emmanuel
Project Assistant, Akanyaru,
Rwanda



Joyeuse Imigambi
Project Assistant, Nyabaronga
Wetland, Rwanda



Kelvin Steven Floyd
Zambian Research Associate



Osiman Mabhachi
Community Project Specialist

Sustainable Development Goals



Aichi Biodiversity Targets



A legend for these icons can be found on pages 9–10.



To learn more about livelihood promotion for the protection of cranes in Rwanda, and more, visit www.youtube.com/user/EWTSouthAfrica

BIRDS OF PREY

PROGRAMME



Bateleur

Protecting African icons

The Birds of Prey Programme is committed to protecting threatened birds of prey and safeguarding the spaces they require to thrive. We protect the irreplaceable ecosystem services they provide and synergistically safeguard their habitats, which support other wildlife, and people. In South Africa, we action smart conservation interventions to preserve the remarkable diversity of raptors, one of the most globally threatened groups of animals. We undertake strategic research to guide applied, hands-on, conservation projects for a wide range of threatened birds of prey; identify and reduce the impact of key conservation threats; protect and recover populations; and secure and create important raptor safe spaces. We achieve this through a combination of practical effectiveness, partnerships, education and awareness, legislative support and robust science.

Over the year under review, we developed a revised programme strategy. This includes three overarching projects: Saving our Scavengers (SOS) – with a particular focus on Africa’s vultures; Saving Our African Raptors (SOAR) – aimed at conserving threatened habitat specialists, migratory birds of prey and African eagles; and lastly, the Raptor Safe Space Project – geared to protecting core raptor habitat.

We work across South Africa in synergy with several other EWT programmes, and collaboratively with key partners and specialist groups involved in each area. These include conservation NGOs, national and provincial nature conservation departments, universities and volunteers.

Saving our Scavengers

Over the last decade, the rapid population decline of vultures across Africa led the IUCN to uplist seven of 11 of the continent's vulture species to Critically Endangered and Endangered. These icons of the savannahs have been extirpated across large portions of their range. The most pervasive threat to vultures is through poisoning, while other significant threats include collisions and electrocutions with electrical infrastructure, loss of breeding and foraging habitat, and drowning in farm dams.

Through our Saving our Scavengers Project, which dates back to 1973 in its various guises, we have maintained our vulture monitoring and tagging programmes across South Africa, including our Platberg Karoo, Kalahari Raptor and Lowveld-Kruger projects. We surveyed and monitored the breeding of over 509 active vulture pairs (23 more pairs than the previous year), colour tagging 230 nestlings, 39 juveniles and 44 adults, and recording over 587 re-sightings of tagged individuals.

Over the last year, we resolved more than ten conflict incidents with farmers, safe-proofing seven farm dams and reservoirs to prevent unnecessary vulture drownings. We played a leading role in drafting and actioning the Multi-species Action Plan to Conserve African-Eurasian Vultures, an important conservation tool for Africa's highly threatened vulture species. We also played a pivotal role in revising the Bearded Vulture Biodiversity

Management Plan, as part of the Bearded Vulture Task Force. With its core in the Kruger to Canyons (K2C) Biosphere, we are excited to have taken a central role in the K2C Hooded Vulture Project. Led by our vulture specialist, Dr Lindy Thompson, we will continue to monitor the Lowveld population of this Critically Endangered species, and to develop effective conservation action plans to help the species recover in its last South African stronghold. The programme has played advisory roles for two researchers from the University of Cape Town.

Through analysis of our valuable population monitoring, GPS-tracking and breeding datasets, collected over the last two decades, we have established that vulture populations, in particular White-backed Vultures (*Gyps africanus*) in the northeastern regions of the country, have undergone the most concerning declines. This information is fundamental to understanding vulture population trends across South Africa.

This project would not be possible without our key sponsors, the Charl van der Merwe Trust and Rand Merchant Bank, as well as our partners from Ezemvelo KwaZulu-Natal Wildlife (EKZN Wildlife) and South African National Parks (SANParks). We are able to cover a lot of conservation ground using our Lowveld project vehicle sponsored by the Ford Wildlife Foundation, for which we are extremely grateful.



Saving Our African Raptors (SOAR)

Knowing, doing, sharing

We developed our SOAR Project to improve our understanding of threatened birds of prey, and to improve the actions and strategies we use to conserve them. This includes their habitat requirements, as well as threats to them, within the dynamic African landscape. We will translate our SOAR research into conservation action that safeguards and promotes core ecosystems for birds of prey (see our Raptor Safe Space Project), as well as guiding the techniques used to rehabilitate, restore and expand suitable habitat. SOAR took shape this year through two main channels: focusing on the conservation and research of threatened eagles, and of sensitive habitat specialists, owls.

Conserving Africa's threatened eagles

The decline of Martial Eagles (*Polemaetus bellicosus*) through South Africa is poorly understood, and echoes a decline in many raptor species across the continent. In South Africa, only an estimated 800 breeding pairs remain. Alarmingly, researchers at the University of Cape Town (UCT) suggest that the species has declined by up to 60% over the last 20 years, including in the Kruger National Park, where the species may have declined by as much as 54%. Working with the FitzPatrick Institute of Ornithology (UCT), we are critically examining the role of protected areas for Martial Eagle conservation. The eagle's poor breeding productivity in the Kruger, from 2013 onwards, relates to both a lower than average number of pairs trying to breed, and low breeding success amongst those pairs. We have installed eight time-lapse cameras at active nests, to understand breeding failure, which we will recover in November 2018. Concurrently, the project continues to investigate individual eagles' movements and survival in Kruger, using GPS tracking and colour ringing.

In June 2018, in partnership with Eskom, we launched the Karoo Martial Eagle project. Here over a third of the breeding population nests on Eskom structures that may have helped facilitate the species' range expansion. This finding is at odds with the generally held belief that Martial Eagles are increasingly confined to large protected areas, and has significant implications for our thinking around their conservation management. The long-term status or sustainability of the Karoo pylon-nesting population is currently unknown, though this significant population may help to bolster other populations that would otherwise be declining. We are critically examining the status and dynamics of this population, including their survival, breeding and foraging behaviours. We will examine changes in this population compared to over a decade ago (from 2002–2006). This year we have established three main breeding study sites along 1,200 km of Eskom transmission lines traversing the southwestern Karoo, using data from as far back as the late 1990s to assist us identify 49 nests, including 30 we will monitor closely.



Distance travelled:
13,500 KM

Area monitored:
4,000 KM²



2

Nestlings



7

Direct interactions
with landowners



Safeguarding habitat specialists

The SOAR Project focuses on applied research and monitoring to improve our understanding of habitat-specialist species and enhance the conservation activities we apply to protect them and their core foraging and breeding habitats. Through the protection of flagship, indicator raptor species, we aim to preserve the sensitive, often highly threatened, ecosystems in which they live.

The protection of pristine Lowveld riparian habitat for Pel's Fishing-owl (*Scotopelia peli*) remains a priority of ours – we have monitored populations along the Olifants River since 2009. This riparian habitat is home to several other threatened raptors, including a large breeding population of Hooded Vultures (*Necrosyrtes monachus*). This year, we implemented research on Pel's Fishing-owls along the Olifants and Blyde rivers to assess the overall health of this highly threatened riparian habitat on which the species depends. Significantly, since 2017, we have discovered 17 new occupied territories. We are also trialling exciting new bio-acoustic monitoring devices, which essentially 'eavesdrop' on the river, and monitor the presence of Pel's Fishing-owls, as well as other species such as African Fish Eagle (*Haliaeetus vocifer*) and African Wood Owl (*Strix woodfordii*). The collection of both feather and pellet samples continues, and we have well in excess of 150 feathers to use for isotope analysis, whilst the pellet samples will allow great insight into the species' prey base. The project is garnering excellent support among local landowners, including awareness of the challenges the owls face. We continue to coordinate the long-term Balule Pel's Fishing-owl survey along the Olifants River, with a current population of around ten pairs, whilst the additional opportunity to record baseline data on the breeding activities of both White-backed and Hooded Vultures is proving extremely valuable.

Our African Grass Owl Project on the Highveld coal belts of Gauteng and Mpumalanga monitored 14 breeding pairs over the last year. We recorded a significantly poorer breeding season than in 2017, with only seven (compared to 12) successful breeding attempts, and two nestlings (compared to 22) colour-ringed. We attribute this partly to uncontrolled fires (with over 45% of our study sites burning to the ground), and livestock disturbance, which displaced Grass Owls (*Tyto capensis*) from their core breeding and foraging territories. These territories are very small, average around 0.45 km² in size, and restricted to relatively undisturbed wetland/grass patches. As suitable habitat is limited, and takes up to three years to regenerate



Black Harrier nestling



White-backed Vulture

after burning, we are extremely concerned about the long-term sustainability of our study population. In response, we have initiated the first rehabilitation trials in Gauteng, at two sites, to recover suitable habitat, and counter the rapid fragmentation and loss of Grass Owl habitat on mines, farms and communal land. We are working with several specialists specifically to restore grass patches of the preferred *Imperata cylindrica* grass.

Key sponsors, include the Charl van der Merwe Trust, the Anglo American: Inyosi Coal, Kriel Colliery, Eskom, Ford Wildlife Foundation and Rand Merchant Bank.



White-headed Vulture fitted with wing tags

Raptor Safe Space Project

Creating safe spaces for threatened birds of prey

The overarching goal of this project is to safeguard, expand and promote core threatened raptor breeding and foraging habitat – ultimately to create raptor safe spaces and corridors linking these. We aim to mitigate, and where possible, remove major anthropogenic threats within these landscapes, including unsafe energy and agricultural infrastructure, roadkill hotspots, poisoning, and human wildlife conflict. We work towards improving land use practices and human based-values/appreciation of birds of prey through education and awareness campaigns.

Wind energy

A significant emerging threat for several threatened raptors, in particular Cape Vultures (*Gyps coprotheres*), Martial Eagles, Verreaux's Eagles (*Aquila verreauxii*) and Black Harriers (*Circus maurus*), is their susceptibility to colliding with wind turbines on wind energy facilities (WEFs). This is particularly important given a significant node of WEF development in South Africa, which is predicted to have a cumulative impact on raptors. Indeed, the last five years have shown concerning numbers of mortalities on wind farms, particularly in the Western and Eastern Cape (13 fatalities in just two years on three operational wind farms). We aim to develop site- and species-specific predictive risk models that will allow us to build real time behavioural profiles. This information is fundamental to making baseline decisions about where to build WEFs, and the strategic placement of turbines, with a focus on facilities close to raptor safe spaces.

This year, we initiated two projects to address these concerns in two collision-prone species. The first investigated mitigation options for the Endangered Cape Vulture on an operational WEF in the Eastern Cape. The second is examining fine-scale spatial use of Martial Eagles in Sutherland, Western Cape, within a proposed WEF. From this, we will develop a suite of recommendations and guidelines for the WEF to ensure that no turbine-related Martial Eagles fatalities occur on the site.

The persistent threat of poisoning

Our second focus is on the single largest threat to scavenging birds of prey, in particular vultures, namely poisoning. This can be through direct poisoning and in association with elephant and rhino poaching, harvesting for trade in vulture parts for traditional medicine and beliefs, or indirect, secondary poisoning linked to the poisoning of problem carnivores, where vultures become the unintended victims. Our work boldly implements both reactive and proactive conservation interventions to reduce the impact of poisoning on birds of prey. Without compromise, our project aims to remove poisons from the landscape in core areas for birds of prey. We capacitate key stakeholders, conservation and law officials to respond to, and manage, poisoning events more effectively, support law enforcement, legislation and the judiciary to improve prosecution success rates linked to the illegal poisoning of wildlife, which will ultimately reduce the use of illegal wildlife activities.

Over the year under review, we trained 122 individuals as part of our Poisoning Intervention and Prevention programme, within known vulture poisoning hotspots in the Lowveld, Mpumalanga, and northern Zululand, KwaZulu-Natal. We also distributed ten Poisoning Response Kits across strategic sites in KwaZulu-Natal. The kits are equipped to deal with scavengers at a poisoning incident, and contain items essential for the collection of evidence left behind by the perpetrators.

Key sponsors, including the Charl van der Merwe Trust, Eskom, Ford Wildlife Foundation, the Mohammed bin Zayed Species Conservation Fund, Rand Merchant Bank, WindLab and Cennergi make our SOAR Project possible. Key partnerships with Avisense Consulting, SANParks, EKZN Wildlife, WildLife ACT and the University of Cape Town have allowed us to achieve far greater impact.



Distance travelled:

15,680 KM

Area monitored:

79,870 KM²



250

Direct interactions with landowners



122

People trained



Martial Eagle

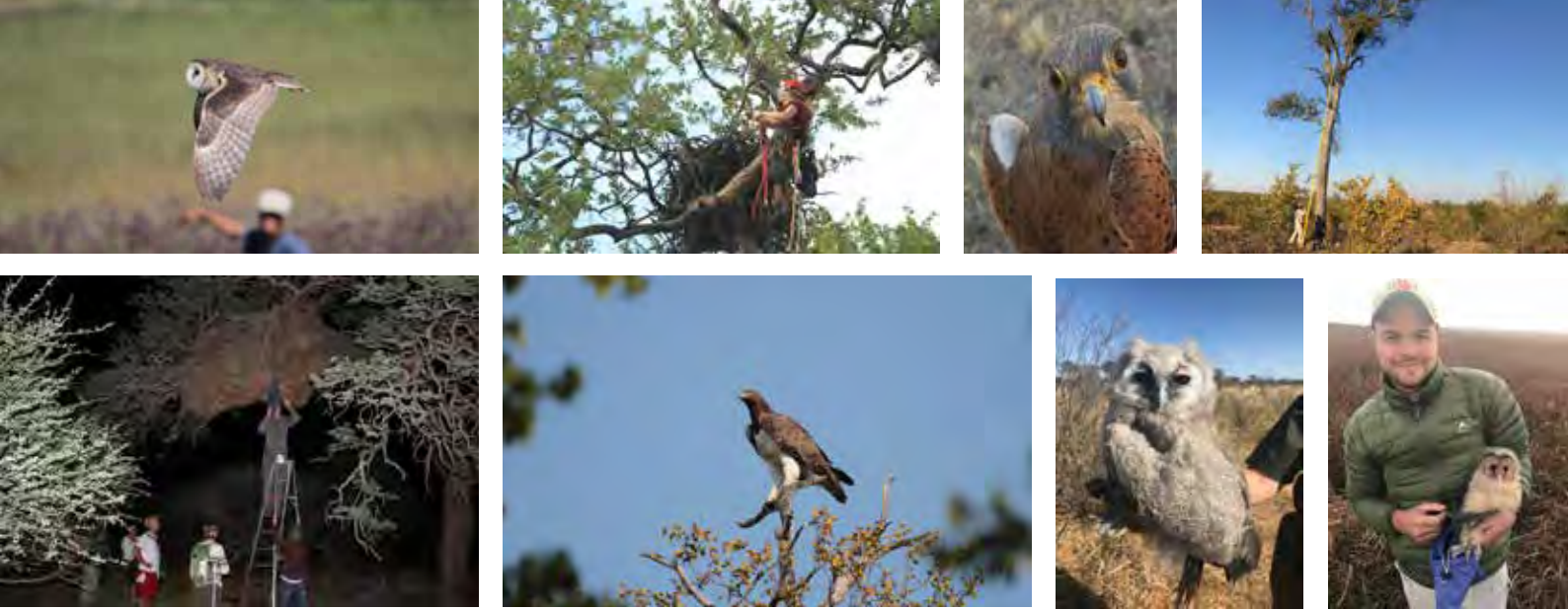

Raptor emergency fund

Every individual counts. On a regular basis, we receive news of injured and poisoned birds of prey, which require rapid action to save them. Birds are collected at the scene and taken to the nearest rehabilitation centres, where they are treated, until they are fit enough for rerelease into the wild. We have established an emergency fund that supports our work, and the rehabilitation centres and individuals/volunteers in cases

where long-term recovery is required. Since its inception in September 2017, we have raised over R25,000, using these funds for the recovery and release of over 20 birds of prey, including eight White-backed vultures, two Cape Vultures, four Secretarybirds (*Sagittarius serpentarius*), two Verreaux's Eagles and 14 owls. We thank all those that donated towards this important cause.

BIRDS OF PREY PROGRAMME TEAM



Dr Gareth Tate
Programme Manager



Rebecca Mabuza
Administrator



Tselane Rachuene
Field Officer: Anglo African Grass Owl Project



Ronelle Visagie
Project Coordinator: Platberg Karoo Raptor Project



John Davies
Project Coordinator: Raptor Conservation and Research



Dr Lindy Thompson
Project Coordinator: Vulture Conservation and Research

Sustainable Development Goals



Aichi Biodiversity Targets



A legend for these icons can be found on pages 9-10.



To see how we create safe space for raptors, addressing land use and human-wildlife conflict, and more, visit www.youtube.com/user/EWTSouthAfrica

CARNIVORE CONSERVATION PROGRAMME

Growing packs and spots

One of the EWT's longest running programmes, the Carnivore Conservation Programme focuses on protecting southern Africa's most threatened carnivores. We implement large-scale, collaborative, field-based projects to increase the range, numbers and status of Africa's threatened carnivores – one of the most charismatic yet threatened groups of animals.

We achieve this by re-establishing, maintaining and expanding safe space for carnivores; actively reducing threats to carnivore survival and persistence; ensuring positive changes in human-based values towards carnivores; and supporting legislation to protect carnivores. Ultimately, our goal is to reverse the global trend of carnivore species decline by actively increasing carnivore populations in southern Africa.

Historic Wild Dog reintroduction to Gorongosa National Park, Mozambique. Photo credit Brett Kuxhausen

Protecting Kruger's Wild Dogs against diseases

In collaboration with South African National Parks (SANParks) and the State Veterinary Department, we continued our ambitious project – a first of its kind for Wild Dogs (*Lycaon pictus*) – to collar and vaccinate Wild Dogs against the canine distemper virus and rabies in the Kruger National Park (KNP). The project also looks to understand the prevalence of disease within this Wild Dog population, and to determine their immune responses to vaccinations.

We have successfully collared every Wild Dog pack in the park. We targeted every pack for vaccination, a complex procedure that requires an initial vaccine, a booster vaccine 6–8 weeks later, and an annual top-up vaccine. To-date, we have sampled 77 individuals of which 71 were vaccinated from 23 packs, of which 60 individuals have received their booster vaccinations to date. Our monitoring indicates that the populations contained 250 individual adults and yearlings in 24 packs, prior to the 2018 denning season – the largest it has been for the past five years and in no small part thanks to the vaccination project. We are

proud to report the project has achieved its goal of protecting 30–40% of the Wild Dogs in Kruger against disease.



Wild Dog pups



13 Wild Dog
38 Cheetah
 Completed relocations



Accounting for the
 safe relocation of:
73 Wild Dogs
50 Cheetahs



Increasing safe space
 for Wild Dogs by:
4,400 km²



and Cheetahs by
198 km²



Optimising safe space for Cheetahs and Wild Dogs: growth, growth and more growth

In South Africa, Cheetahs (*Acinonyx jubatus*) and Wild Dogs require hands-on management of their populations to maximise conservation impacts for both species. Two of our oldest and most successful projects have been dedicated to the increase in their safe space, numbers and genetic diversity through proactive reintroductions and translocations of both species from one protected area to another. This year we achieved incredible success on a national, regional and global scale – completing 13 Wild Dog and 38 Cheetah relocations, accounting for the safe relocation of 73 Wild Dogs and 50 Cheetahs, increasing safe space for Wild Dogs by 4,400 km² and Cheetahs by 198 km². These relocations include some notable highlights:

Wild Dogs

We reintroduced 14 Wild Dogs into Gorongosa National Park in Mozambique, a critical move in restoring predators to this

ecosystem, where they had disappeared during Mozambique’s 16-year civil war. This being the first ever Wild Dog reintroduction in Mozambique’s history, the park represents an additional 4,000 km² of safe space for these carnivores. We sourced this founder population from reserves in South Africa. Two females became pregnant within three months with the hope of a new generation for Gorongosa.

Since 1995, there has been a prolonged decline of Wild Dogs in the northern KNP. After many years of effort, we finally augmented this northern population through the reintroduction of a pack of eight Wild Dogs into the Shingwedzi area. The pack has since denned and had two pups, highlighting the success of this reintroduction. This pack has also enabled cross border collaboration with the Greater Limpopo Carnivore Program, where the pack has spent time in Mozambique’s Limpopo National Park.

We increased safe space for Wild Dogs in South Africa by an additional 400 km², through their reintroduction to Maremani Game Reserve in Limpopo Province.

Six new packs were established to ensure that inbreeding is avoided and that genetic diversity is increased. This includes three packs within KwaZulu-Natal and Gorongosa, northern KNP and Maremani.

Cheetahs

We reintroduced Cheetahs into six new reserves, including Marakele National Park, Mapesu, Mabote, Roam and Rietpoort Private Game Reserves. The Roam reintroduction brings wild Cheetahs back into the Central Karoo region after a 130-year absence.

Collaborating with African Parks, the seven Cheetahs we previously relocated to Liwonde National Park in Malawi have adapted well to their new environment, with two females giving birth to three cubs each – the first wild Cheetahs born in Malawi since 1989, constituting a massive success for the species. We relocated a further three Cheetahs from South Africa to Malawi in 2017, bringing with them new genetics to prevent inbreeding. Incredibly, the Liwonde Cheetah population has expanded to 15 individuals in just one year.

Hluhluwe-iMfolozi Park is one of the larger Cheetah metapopulation reserves, yet in 2015 only three Cheetah lived here, a far cry from the approximately 40 Cheetah assumed to be resident in 2011. Working with Wildlife ACT, we released a further seven Cheetahs into the Park, of which six now survive.

Overall, we now have 250 Wild Dogs in 26 packs and 340 Cheetahs under our population management. Wild Dog numbers remain stable, whilst Cheetah numbers have increased by 8%.



Wild Dogs arriving in Gorongosa National Park, Mozambique. Photo credit James Byrne



First Cheetah born in Malawi in 30 years. Photo credit Olivia Sievert

Results of safe space, number and inbreeding from the Cheetah Metapopulation project.

	Cheetah Metapopulation June 2011	Cheetah Metapopulation July 2018	Trend
Number of metapopulation reserves	43	53	↑
Number of metapopulation Cheetah	217	340	↑
Total area occupied by metapopulation (total safe space, km ²)	8,261	12,160	↑
Percentage of reserves inbreeding	42%	17%	↓
Percentage of surplus metapopulation Cheetah sold to captivity	28%	0%	↓
Percentage of relocated Cheetah lost to immobilisation complications	23%	11%	↓

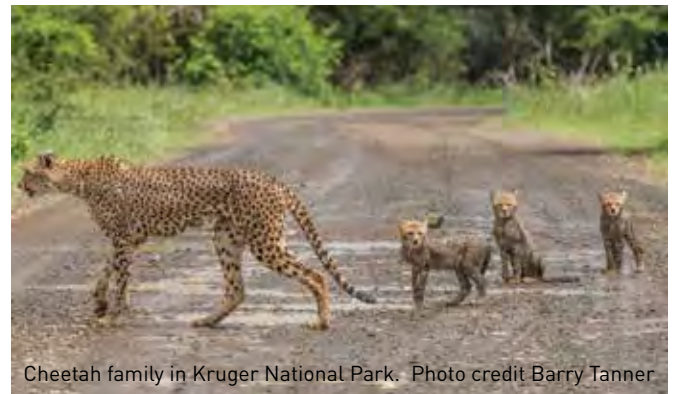

Cheetah family in Kruger National Park. Photo credit Barry Tanner



Addressing snaring

Snaring continues to threaten carnivores, both inside and outside protected areas. Six snares were reported on Wild Dogs in the KNP this year, of which we were able to remove five from living animals, with the other individual succumbing to its horrific injuries. Elsewhere a further seven Wild Dogs were reported with snares, including the first Wild Dog snare mortality in Hluhluwe-iMfolozi Park's history.

At least two Cheetahs were also snared, of which one died from the snare, while the other was left with severely damaged teeth while trying to escape the snare, leaving its prospects of recovery poor. The increasing loss of carnivores to snares is a grave concern, with reports of Leopards and Lions in the KNP being snared, as well as a number of Leopards in the communal areas of the Waterberg and Soutpansberg. We intend to tackle this issue moving forwards.



Man's best friend defending livestock on rural and commercial farms

On South African farmlands, conflict between people and carnivores is rife. This arises mainly when carnivores predate on livestock, leading to retaliatory killing of predators by farmers. To demonstrate, we uncovered seven Leopards that had been poisoned within the last two years in rural communities north of the Waterberg. One of our key approaches that works for farmers and predators alike is the use of livestock guarding dogs – a non-lethal control method. These dogs live with the livestock and protect them from predation, reducing losses, making farming more profitable and removing the need for farmers to kill carnivores.

We are building on the success of our conservation work in the Waterberg by increasing its scope to include rural farming communities. Here unselective methods, such as poisons and snares, are used to persecute 'problem' predators. This is the first time that we are placing livestock guarding dogs with rural farmers, and highlights the programme's approach to working in new spaces to save carnivore populations. This year we placed 11 livestock guardian dogs in rural communities, and six with commercial farmers, and recorded a 100% reduction in stock losses. Not one loss was incurred on the farms we worked with this year, a notable success! Through this work, we believe that we can save all carnivores that live in the Waterberg, Soutpansberg and Magaliesberg by creating corridors of safe habitat between reserves.



Protecting the last free roaming Wild Dog pack in South Africa

Despite the major threats Wild Dogs face, especially outside protected areas, a single free-ranging Wild Dog pack still manages to survive in the Waterberg. Given the importance of preserving the genetics of South Africa's last free-roaming Wild Dogs, our goal is to safeguard this last surviving pack. The consortium of landowners in the area practice varied land uses ranging from fully protected reserves and livestock farming to commercial hunting and intensive game breeding. Even though they hold no conservation worth, the commercial value of rare antelope colour morphs was, until recently, extremely high, while disease free herbivores are bred here too. Predictably, predation on these species by naturally occurring carnivores is generally not tolerated, and retaliatory killings are common practice. This has undoubtedly contributed to the decline of the free-roaming population of Wild Dogs in the Waterberg, from about 80 in 1998, to just one pack of five in 2017.

Protecting these Wild Dogs is a challenge under these circumstances, and we are therefore developing an innovative eco-tourism model. The underlying enabling condition for the pack to survive is that farmers' livelihoods are not substantially affected by the Wild Dogs. To this end, we have engaged with all landowners in the area and fitted tracking collars to the pack to provide an early warning system of the pack's whereabouts, and potential hot spots for conflict. We are also distributing tourist revenue generated through Wild Dog tracking excursions back to landowners according to the space-use of the pack. As a result, the whole Waterberg Community has come out to support this pack and the project has received a lot of positive publicity. The Wild Dogs are benefiting too, as the pack of 12 has denned on a small farm owned by landowners who have bought into the idea and will give this pack a chance to raise their pups.

Photo credit Dr Antoine Marchal

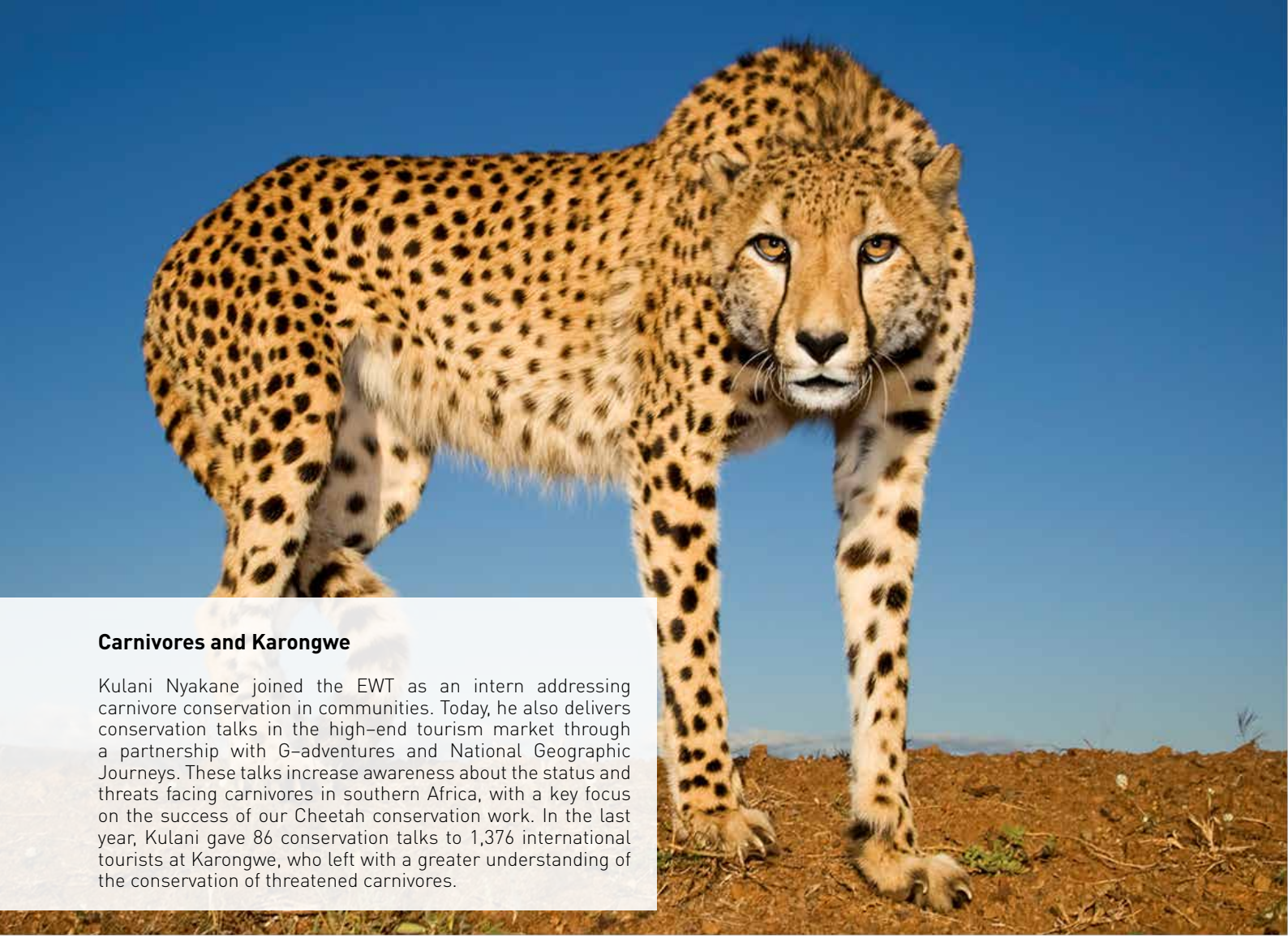

Carnivores and Karongwe

Kulani Nyakane joined the EWT as an intern addressing carnivore conservation in communities. Today, he also delivers conservation talks in the high-end tourism market through a partnership with G-adventures and National Geographic Journeys. These talks increase awareness about the status and threats facing carnivores in southern Africa, with a key focus on the success of our Cheetah conservation work. In the last year, Kulani gave 86 conservation talks to 1,376 international tourists at Karongwe, who left with a greater understanding of the conservation of threatened carnivores.

Legal teeth

We continue to play an active role in supporting a robust legal framework for carnivores. With the national government providing less and less funding for the effective protection of endangered species, our role is vitally important in providing a voice for species that cannot speak for themselves. Right now, we are trying to keep Wild Dogs in Tembe Elephant Park, working to balance conflicting perceptions about whether this is a suitable site for Wild Dogs. We firmly believe that the park can play a vital role in national Wild Dog conservation.

We are also working with the EWT's Wildlife in Trade Programme, using applications under the Promotion of Access to Information Act, to determine if organisations in the Lowveld have gone through the correct legal channels with respect to Cheetah and Wild Dog management. We need to ensure that we are not losing wild Cheetahs and Wild Dogs to captive facilities, and that all activities related to these species follow the correct legal framework.

For two years, we have urged the North West Parks and Tourism Board to swap Cheetahs between the Pilanesberg National Park and other Cheetah reserves to retain genetic integrity of the populations. and the North West provincial government has finally agreed to relocate surplus Cheetah and to introduce new genetics into the reserve. We have also relocated three

male Cheetahs to Marakele National Park and Dinokeng Game Reserve, while two male Cheetahs were sourced from Shamwari Private Game Reserve for relocation to Pilanesberg. They will bring with them much-needed new blood into the Pilanesberg Cheetah population.

We continue to refine the national Cheetah and Wild Dog Biodiversity Management Plan and will organise a stakeholder workshop in 2018 to determine timeframes and responsible organisations for finalising the plan.



Relevant research

Through our collaboration with SANParks and the State Veterinary Department, we have gained incredibly valuable insight into the prevalence of disease in Wild Dogs in KNP. Our results show that Wild Dogs in the KNP have low baseline immunities towards rabies and the canine distemper virus, and that another outbreak could severely compromise the population. This highlights the importance of continuing our vaccination project. On the other hand, despite the high prevalence of exposure to TB in the KNP, there is only one record of a Wild Dog succumbing to this disease in the park. This shows that the KNP Wild Dog population can handle TB well, and that it is not a large threat by itself to Wild Dog population persistence. We have been working with Dr

Courtney Marneweck, Dr Antoine Marchal and Prof Dan Parker from the University of Mpumalanga on the Kruger Wild Dog work. Courtney is assisting the programme with our long-term dataset on Wild Dogs to determine factors driving population dynamics, space use and the historical decline of Wild Dogs in the KNP. She submitted a paper, working with members of the Wild Dog Advisory Group of South Africa, on factors affecting success in artificial bonding of Wild Dogs. Antoine has assisted with our northern KNP project. We continue to work with Dr Laura Tensen from the University of Johannesburg on the genetic health of Wild Dogs within the KNP, the metapopulation and free-roaming packs.



Looking for female Wild Dogs in KwaZulu-Natal

CARNIVORE CONSERVATION PROGRAMME TEAM



David Marneweck
Programme Manager



Derek van der Merwe
Limpopo Regional Coordinator



Vincent van der Merwe
Eastern Cape Regional Coordinator



Grant Beverley
Lowveld Regional Coordinator



Cole du Plessis
KZN Regional Coordinator



Kulani Nyakane
Lowveld Carnivore Cons. Community Intern



Joseph Hlako
Waterberg Community Conflict Mitigation Intern

Sustainable Development Goals



Aichi Biodiversity Targets



A legend for these icons can be found on pages 9–10.



To watch a Cheetah relocation in action, and more, visit www.youtube.com/user/EWTSouthAfrica

CONSERVATION

SCIENCE UNIT



Evidence-based conservation

The Conservation Science Unit is the EWT's scientific hub. We provide scientific support across the organisation's programmes and projects, to ensure that our work is scientifically sound and evidence-based. We manage the organisation's central Biodiversity DataBank and build capacity among staff, and our partners, to analyse, interpret and publish the results of our conservation research, making it accessible to diverse audiences. We also run special projects, such as the Mammal Red List Revision, which do not fall within the scope of other programmes.

The CSU contributes to the EWT's crosscutting approaches for achieving the organisation's goals, in particular crosscutting approaches 2 (skills and capacity development) and 4 (robust science and evidence).

Open Standards for the Practice of Conservation

To ensure that our conservation actions are impact-driven, efficient and effective, the EWT has embarked on a journey to integrate the Open Standards for the Practice of Conservation into all of the EWT's programmes and departments. The Open Standards help teams to be systematic about planning, implementing, and monitoring their conservation initiatives, by measuring, adapting and improving their work for the benefit of biodiversity. "Miradi" – a Swahili word meaning "project" – is a user-friendly software programme that assists conservation practitioners through the Open Standards process. The CSU has provided technical support for the Open Standards process, including detailed training sessions, presentations and practical workshops involving all staff to ensure that they understand how their individual efforts contribute to the success of their projects, as well as EWT's broader conservation vision.



THE RED LIST OF MAMMALS OF SOUTH AFRICA, SWAZILAND AND LESOTHO

The South African Mammal Red List 2016 was made possible by many institutions and researchers who contributed towards the assessments or provided data.

Sector	% of contribution to assessments (N = 331)	% of data Contribution (N = 460,93)
Governmental institutions	18.2	52.3
Research institutions	55.5	34.6
Non-governmental organisations	17.1	4.0
Private sector	9.2	2.8
Citizen science	0	6.2

All 331 Mammal Red List assessments are freely available at <https://www.ewt.org.za/reddata/reddata.html> or by scanning the following QR code:



It's a wrap – the Mammal Red List

We launched the Mammal Red List of South Africa, Lesotho and Swaziland at the end of 2017. This Red List provides an up-to-date assessment of the state of our mammals, of which 57 (17%) are deemed to be threatened with extinction and 34 (10%) are Near Threatened. Overall, 331 species, subspecies or subpopulations were assessed, compared to 295 in the 2004 assessment, where 19% of taxa were threatened and 13% were Near Threatened.

Do you know which South African mammal species are threatened?

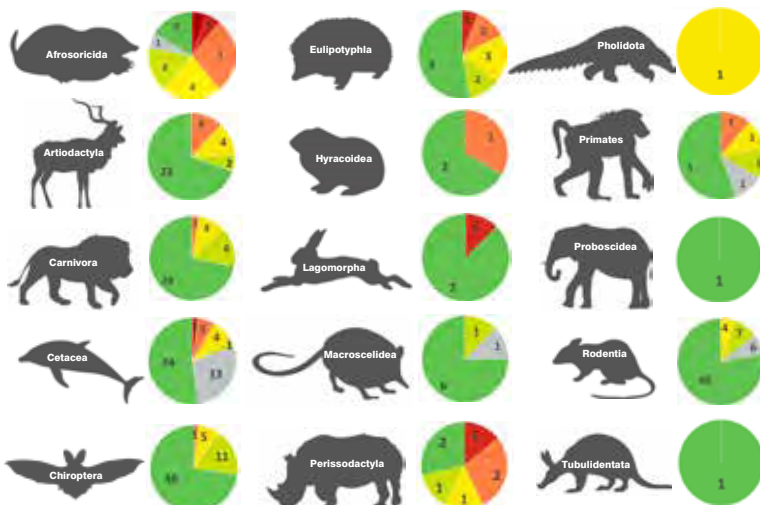

Key to Red List status categories

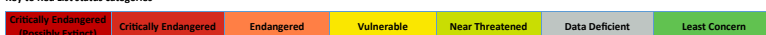

While the latest update appears to list proportionately fewer threatened species, most of these changes were non-genuine due to improved knowledge on their distribution, abundance and taxonomy. However, of the genuine changes detected thus far, 19 (66%) are uplistings (more threatened). This indicates that no net conservation gains have been made over the past decade. The assessments are freely available on the EWT's website.

We have also handed the South African National Biodiversity Institute (SANBI) a database of some 460,000 mammal-occurrence records, representing data compiled from at least 58 different institutions, plus private individuals and published literature. This database will inform future Red List revisions and other conservation assessments, including an ongoing project on assessing the protection levels of South Africa's mammals.

Biodiversity DataBank

Our progress towards the establishment of the EWT's Biodiversity DataBank took a leap forward this past year with mentorship provided by one of our partners at the International Crane Foundation, in the establishment and maintenance of SQL databases. We currently house 194 biodiversity datasets, 141 of which are still active.

To assist programmes to make field data collection and data management simpler, we have developed customised data collection apps, through our NPO GIS licence from ESRI South Africa. Mobile apps have been trialled by the Carnivore Conservation Programme, for capturing data during darting and collaring of Wild Dogs, as well by the Drylands Conservation Programme, for collecting data on Riverine Rabbit observations.

We will expand the number of apps in use in the coming year. The CSU assisted the Drylands Conservation Programme to compile the first national database on Riverine Rabbit sightings, and to develop a standardised template for capturing these. Our work is a first step towards standardising data capture, and using a holistic dataset to plan further conservation interventions for this Critically Endangered species.

To guide conservation interventions and identify geographic gaps, on an organisation-wide scale, the unit developed a strategic priorities map, taking into account the distribution ranges of all threatened vertebrates and threatened ecosystems in South Africa.



Riverine Rabbit range in the Karoo



Areas of high biodiversity importance in South Africa



Mammal distribution records compiled for the Red List revision:

460,000



Number of EWT biodiversity datasets held by the CSU:

194, of which 141
are still in active use

Scientific publications

The EWT published 11 scientific papers this year. While this is fewer than in 2016, we also published three book chapters, a conference proceedings, and two technical reports, and we have a large number of papers in preparation. To reach a wider non-scientific audience, we published summaries of six of these in the EWT's bimonthly *Conservation Matters* magazine.

Our data making a difference

We received 35 requests for data over the past year, and were able to provide data in 18 cases, three for use in conservation planning, four in Environmental Impact Assessments, and 11 for research. We shared four additional datasets with partners under various student and researcher agreements. While a wide variety of data was requested from 12 of our programmes, data from the Birds of Prey Programme – in particular their ongoing datasets on vulture satellite tracking and poisoning mortalities – were most frequently requested.

Partnerships

Dr Lizanne Roxburgh continues to serve on the African–Eurasian Migratory Waterbird Agreement (AEWA) Technical Committee, as the representative for southern Africa. Over the past year, AEWA developed a new 10-year Plan of Action for Africa, to further promote and improve the management and protection of waterbirds on the continent, and finalised various technical reports in preparation for the next Meeting of Parties to be held in South Africa at the end of 2018.

The EWT is an associate node of the Global Biodiversity Information Facility (GBIF) and we are part of the African group of nodes, one of the most active regional groupings within GBIF. We continue to make our data freely available on the GBIF platform, including over 29,000 Cheetah and crane occurrence

records. These datasets have been downloaded 2,578 and 2,829 times, respectively, and both have received formal citations in scientific papers.

Dr Lizanne Roxburgh is a formal GBIF mentor and participated in training and mentoring of a group of participants in the African Biodiversity Challenge, which is a project run in association with GBIF that aims to mobilise priority biodiversity data in various African countries and build capacity in biodiversity data management and use.



CONSERVATION SCIENCE UNIT TEAM



Dr Lizanne Roxburgh
Senior Scientist



Samantha Page-Nicholson
Senior Science Officer



Claire Relton
Conservation Science Officer

Sustainable Development Goals



Aichi Biodiversity Targets



A legend for these icons can be found on pages 9–10.



To discover more about the Mammal Red List and its impact on conserving species in South Africa, and more, visit www.youtube.com/user/EWTSouthAfrica

DRYLANDS

CONSERVATION PROGRAMME

Conserving the Karoo

Our mission is to secure and protect the outstanding biodiversity of the Karoo drylands. We do so through innovative conservation approaches that are underpinned by science, inclusive of people, and driven by our determination to have an impact on the landscape and the species it sustains.

The conservation of Karoo drylands biodiversity is primarily vested with commercial and emerging farmers. With this in mind, our conservation strategies strive to integrate the needs of people with those of conservation, to enhance the impact and sustainability of our conservation actions. An essential part of this approach is to demonstrate the value of conservation to the communities where we work. Together with this “living working landscape” approach, we are taking action to secure landscapes and habitat for endangered and flagship drylands species. Research forms a cornerstone of our work and is directly translated into efficient and effective conservation actions.

The Drylands Conservation Programme is about discovery, creativity, adventure and pragmatic conservation action.



270,000 ha
of grazing land assessed during
farmer surveys

Sustainable land management

This year we launched an ambitious five-year project to promote and embed sustainable land management (SLM) in the Karoo agricultural landscape. It is imperative that we engage the land users in the drylands more directly in order to conserve at the landscape scale. SLM holds the key to developing resilience in the face of climate change and challenging economic times, in which there increasing pressures on natural resources and species. Farming for profit, while maintaining the ecological integrity of the environment will require increasingly creative and innovative management approaches. Farmers hold the key to conservation in the Nama Karoo. They are the custodians of large tracts of land that hold most of the Karoo's biodiversity. Who better to champion innovative approaches than the farmers themselves?

This year we have laid the foundation for the next three years of the SLM project. We have done this through the development of a "peer to peer" strategy to promote SLM with a number of emerging and commercial farmers who are interested in

implementing SLM practices on the landscape. At the heart of our approach is a farmer champion model that encourages farmers to explore SLM and what it means for their farming operations. We have targeted 30 commonage farmers around Loxton (covering 15,000 ha) and 5 emerging commercial farmers between Loxton and Beaufort West (covering 23,000 ha). We have also selected three champion farmers near Victoria West, Loxton and Nieuwoudtville, who will be our ambassadors for the project.

Our work will result in a scalable and replicable programme that will encourage sustainable land management in the Karoo and beyond and provide support to emerging landowners. Better planning and practices will result in better habitat for highly threatened arid zone species such as the Riverine Rabbit. This initiative is funded by the Global Environmental Facility (GEF) and supported by the United Nations Development Programme and the Department of Environmental Affairs.



40

Emerging farmers engaged in the period



30

Combined years of institutional agricultural knowledge providing inputs at our integrated farm planning course development session held in Beaufort West in May 2018



110

Confluences assessed

Innovation

The Riverine Rabbit (*Bunolagus monticularis*) and other species on which we focus, are mostly specialised and difficult to locate. Their secretive, solitary behavioural ecology makes them challenging to understand and conserve, requiring us to apply innovative conservation approaches.

In September, we collaborated with a team of thermal imagery experts from Liverpool John Moores University, to attempt to detect Riverine Rabbits using thermal cameras. To our great excitement, we were able to pick up images of rabbits, and we will shortly publish a research paper on the novel detection techniques we have developed.

Our work on innovative conservation approaches received a further boost when Programme Manager, Cobus Theron, obtained his Remote Aircraft Pilot's (drone) licence. Our programme will use these technologies for the benefit of conservation, including in combination with thermal imagery and other technological approaches.

Another innovative approach is the use of a scent detection dog to locate Riverine Rabbits. We took on the daunting task of training a dog without a live target, but using only scent samples from dead specimens – the hair of individuals run over on the road. Our work is exploring ways to train dogs to locate elusive Critically Endangered species where handling a live animal is simply not an option. Preliminary field trials have commenced and we are hoping to publish our results in 2019.

Rand Merchant Bank (RMB) and Zoologische Gesellschaft für Arten- und Populationsschutz (ZGAP) support the DCP in exploring innovative approaches in conservation.



500

Quadrants surveyed for species, cover and cover per species as part of riparian habitat condition assessments

Species and habitat conservation

In April 2018, we held a Riverine Rabbit strategy workshop to revise our approaches to effectively conserve this Critically Endangered species in its northern and southern strongholds. The outcome was a detailed and ambitious action plan aimed at downlisting the species to Endangered by 2023, through identification and protection of viable populations and habitat. After the workshop, we initiated an extensive mapping exercise, incorporating data on the rabbit and its habitat, including temporal analysis of rabbit distribution and habitat condition. This mapping helped us to identify priority conservation areas and corridors for Riverine Rabbits, as well as understanding habitat degradation patterns and trends.

We are constantly exploring new ways to secure critical habitat for conservation, and in the past year we received a rapid assessment grant from Rainforest Trust to investigate the viability of using conservation servitudes to secure habitat for Riverine Rabbits. Conservation servitudes are a novel application of the servitude concept, directly comparable to the American easement model, which is also used for conserving important habitats. We aim to use servitudes to secure sufficient habitat to meet our conservation targets, changing the way we approach conservation of habitat for Riverine Rabbits, and many other species too.

We presented two sites, situated in the Western Cape, to CapeNature for consideration and inclusion in the Biodiversity Stewardship Programme. Both sites would qualify as Nature Reserves. Once declared, these sites will contribute more than 31,000 ha towards the protected area network in the Western Cape. We also presented a training workshop, in collaboration with the Northern Cape Department of Environment and Nature Conservation, on the development of a strategy and benefits packages for the provincial Biodiversity Stewardship Programme. Several NGOs and officials from various provinces attended.

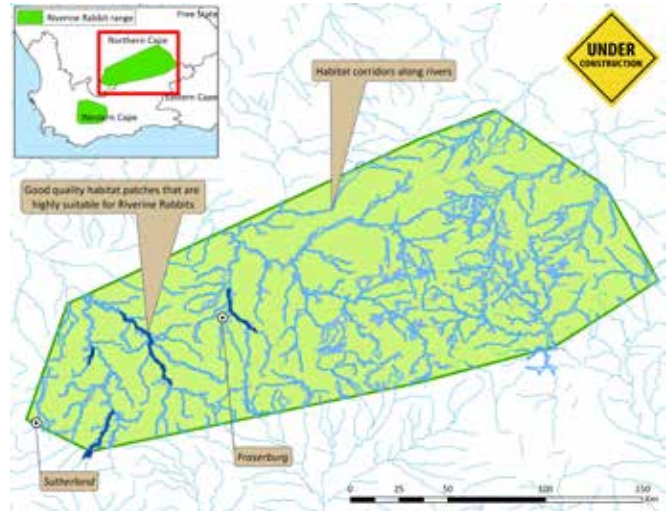

Identification of priority areas for Riverine Rabbit conservation



DCP and CSU teams get together for strategic planning

Social impact

Our presence in Loxton has yielded positive outcomes for the community living there, delivering considerable social impact. This work is founded on the premise that conservation interventions and societal wellbeing go hand in hand. Our initiatives in this period included:

- Completing the first year of the Clever Rabbit Project to improve learning skills of pupils with learning disabilities, with learning approaches incorporating environmental lessons.
- Various environmental education outreach events to highlight the need for habitat and species conservation.
- A sterilisation drive of domestic pets in Loxton and Carnarvon, conducted in collaboration with EnviroVet and the International Fund for Animal Welfare (IFAW). This work has direct conservation benefits, as uncontrolled domestic

animals are responsible for livestock and wildlife mortality on the periphery of Karoo towns.

- The planning and establishment of the Loxton e-learning centre, which will allow for new ways of learning about the environment and sustainable livelihoods. This project will support a number of our other project activities.
- Initiating a project to incorporate additional community involvement at our nursery through training and economic opportunities.

The Karoo drylands present an ever-expanding array of unique opportunities that demand creativity, innovation and the willingness to see conservation challenges from different perspectives. The merging of historical, contemporary and future influences on the landscape creates a challenging environment along with new conservation frontiers.



Pets (51 cats and 94 dogs) sterilised, dewormed, dipped and vaccinated in Loxton as a result of our collaboration with Envirovet, and the International Fund for Animal Welfare (IFAW)



Species specificity – Jessie’s ability to detect Riverine Rabbit scent, in the presence of Red Rock Rabbit and hare species scent



Domestic animals sterilised, dewormed, dipped and vaccinated in Carnarvon as result of collaboration between EWT EnviroVet and IFAW



Jessie the scent detection dog and her handler, Esther Matthew

What our stakeholders are saying

"The project has had a very positive impact on both the learners and the teachers at the school. I would hereby like to express my sincere appreciation to the people and the organisations involved in making this project a reality in Loxton. The Endangered Wildlife Trust, in particular, has a long history of positive involvement in the Loxton Community." – Mr Gordon Lottering, Principal, JJ Booyesen Primary School, Loxton, commenting on the Clever Rabbit Project.

800 Learners reached through environmental education

250 Learners at JJ Booyesen Primary School in Loxton assisted with learning support through the Clever Rabbit Project

13 Educators teaching in Loxton – all were trained to better assist learners with learning disabilities as part of the Clever Rabbit Project



DRYLANDS CONSERVATION PROGRAMME TEAM



Cobus Theron
Programme Manager



Bonnie Schumann
Senior Field Officer



Esther Matthew
Specialist Conservation Officer
Jessie, Scent Detection Dog



Insauf De Vries
Administration Officer



Johnny Arends
Handyman and Nursery Worker



Hester de Wee
Nursery Keeper

Sustainable Development Goals



Aichi Biodiversity Targets



A legend for these icons can be found on pages 9–10.



To learn how we use technology to find the elusive Riverine Rabbit, and more, visit www.youtube.com/user/EWTSouthAfrica

NATIONAL BIODIVERSITY AND BUSINESS NETWORK



Building the capacity of business as a positive force for nature

The world of risks and opportunities within which businesses operate is rapidly changing. Companies are facing increasing pressure from consumers who want to know that they are dealing with responsible corporate citizens, and the impact that companies have on biodiversity is a critical element of this. Companies are becoming increasingly aware of the important role that biodiversity plays in their value chains and there is a need to identify and manage the business risks and opportunities that result from their interactions with biodiversity to avoid negative impacts on their bottom line.

With a significant stake in the sustainability of biodiversity, business has the power and responsibility to act as a powerful lever for change. Recognising the importance of biodiversity to business, the EWT led the establishment of the National Biodiversity and Business Network (NBBN) in 2013, in collaboration with founding partners De Beers, the Department of Environmental Affairs (DEA), Hatch Africa, Nedbank, Pam Golding Properties, Pick n Pay, and Transnet. In 2016, Woolworths and Eskom joined the network.

The purpose of the NBBN is to build the capacity of business to act as a positive force for the conservation of biodiversity in South Africa. The goal of the NBBN is to support action to reduce businesses' impacts on biodiversity. The NBBN is thus a key contributor towards the EWT's strategic imperative of benefitting people.

Through our projects, we work with innovative business leaders to identify and manage the business risks and opportunities that result from their interactions with the natural world. We provide a platform for businesses to proactively engage with each other and discover solutions that lead to sustainable business growth and many exciting business opportunities such as new sources of revenue and the opportunity to reduce production costs.





Building the capacity of business through information sharing

The NBBN's information sharing and networking events aim to build the capacity of South African businesses and related sectors such as government, consulting, NGO and academia, to better integrate biodiversity into all levels of business. Over the past year, we presented two such events.

The first event, held in July 2017, was entitled Finance Sector Supplement to the Natural Capital Protocol, and was presented in partnership with the Natural Capital Protocol, Integrated Sustainability Services, and Nedbank. The Finance Sector Supplement to the Natural Capital Protocol aims to guide financial institutions on how to incorporate environmental impacts and dependencies into their lending, investment, and insurance practices. The workshop set out how natural capital builds, and goes beyond, environmental, social, and governance activities, helping to improve financial decision-making. It was part of a global series of events aimed to input into the development of the standardised guidance.

The NBBN presented its third annual National Biodiversity and Business Indaba in October 2017. Proudly sponsored by the DEA, Hatch, De Beers, Woolworths, Pick n Pay, Nedbank, Eskom, and Painted Wolf Wines, the event attracted over 100 delegates from various sectors, including forestry, mining, agriculture, finance, insurance, oil and gas, retail and consulting, as well as academia, the NGO sector, and government. Highlights of the event included an opening address from Ms Nosipho Ngcaba,

Director General of the DEA, and keynote addresses from Shameela Ebrahim, Senior Strategist at the Johannesburg Stock Exchange, and Deidre Herbst, Environmental Manager at Eskom. With a theme of "Biodiversity for Better Business", the indaba exceeded the expectations of delegates for a two-day programme filled with the latest developments and case studies relating to business and biodiversity in South Africa.





Biodiversity Disclosure Project

The NBBN is in the process of developing a Biodiversity Disclosure Project (BDP), which will be in place by 2020. It will support the private sector in integrating biodiversity into their strategies and activities, thereby helping businesses recognise, measure, value, and responsibly manage their direct and indirect dependencies and impacts on biodiversity. Eskom, South Africa's parastatal power utility company, proudly supports the development of the BDP.

The BDP will drive broad business action in the area of biodiversity mainstreaming in South Africa within the next three years. To achieve this goal, the BDP team (comprised of the EWT's Shelley Lizzio, Constant Hoogstad and Yolán Friedmann, and Dr Joel Houdet of Integrated Sustainability Services), in collaboration with stakeholders, will develop the following three tools: the Biodiversity Disclosure Project Platform, the Biodiversity Measurement Protocol, and the Mainstreaming Biodiversity into Business Toolkit.

Black Mountain Mining

Since 2015, the NBBN has been supporting the IUCN on the implementation of their partnership with Black Mountain Mining (BMM). The goal of the partnership is to support BMM with the implementation of the mitigation hierarchy for their Gamsberg Project in the Northern Cape. The NBBN works with the IUCN and the Gamsberg Project team, providing specialist advice on matters relating to biodiversity mainstreaming with the aim of reducing the company's impact on biodiversity and effectively offsetting their residual biodiversity impact.

In 2017/18 the NBBN has been focusing on assisting BMM with the implementation of the management actions listed in the Gamsberg Biodiversity Management Plan (BMP). This involved weekly teleconferences to track progress with the implementation of the BMP, as well as regular visits to site to provide face-to-face support. Furthermore, in May 2018 the NBBN and the IUCN presented at the 2018 International Association for Impact Assessment's international conference in Durban, South Africa on the partnership between BMM and IUCN.





Networking business partners

The NBBN distributes a monthly newsletter to its database of more than 600 members, keeping these members up to date with the latest biodiversity and business information from across South Africa and the world. We use regular emails to communicate our upcoming events with our members. Our newsletter presents an opportunity to showcase the sustainability work of our partners, present NBBN thought leadership pieces, and to share information on the new projects being developed by the NBBN, such as the BDP mentioned above.

The achievements of the NBBN would not be possible without the support of its partners. We would therefore like to take this opportunity to thank our partners, including Nedbank, Pick n Pay, Hatch, Anglo American, Transnet, the Department of Environmental Affairs, Eskom and Woolworths, for their continued support.

What our stakeholders are saying

“Transnet believes that the success of our business is highly dependent on healthy ecosystems, that is why biodiversity has emerged on the corporate agenda as both a risk and an opportunity that must be managed through more rigorous impact assessments, participatory planning, knowledge management, capacity building and environmental management systems to reduce direct and indirect pressures on biodiversity and promote sustainable use of resources.” – Mapaseka Lukhele, General Manager: Corporate Sustainability, Transnet

“Biodiversity loss remains one of our most significant areas of environmental business risk in terms of both impact and likelihood. Improving our biodiversity performance is important in order to protect our ongoing access to land but also to reduce financial, regulatory and reputational risks. In April this year, we launched our Group Sustainability Strategy, which includes a strong focus on biodiversity and associated goals to deliver Net Positive Impact through implementing the mitigation hierarchy and investing in biodiversity stewardship. Partnerships and collaboration are at the heart of this strategy and we have committed Anglo American’s support to the National Biodiversity and Business Network, taking over from where De Beers started and ensuring we cover all of our respective business units within South Africa”. – Warwick Mostert, Biodiversity Principle, Anglo American.

NATIONAL BIODIVERSITY & BUSINESS NETWORK TEAM



Shelley Lizzio
Programme Manager



Dr Joel Houdet
Consultant

Sustainable Development Goals



Aichi Biodiversity Targets



A legend for these icons can be found on pages 9–10.



To learn about our Biodiversity Disclosure Project, and more, visit www.youtube.com/user/EWTSouthAfrica

SOURCE TO SEA

PROGRAMME

Water works

In South Africa, nearly 71% of our major rivers are regarded as threatened. The main culprits include altering and fragmenting river flows; abstracting water for agriculture, sanitation and drinking; and releasing unprecedented amounts of pollutants into water bodies. In order to support the sustainability of freshwater ecosystems, and ensure resilience of the communities that rely on them, it is important to manage and conserve rivers that remain in relatively good condition. Our programme works at the coalface of conservation, and through a range of multi-sectoral partnerships. Together, we implement innovative and catalytic solutions to address direct threats to aquatic ecosystems and their root causes.



Bazaruto Dugongs and seagrass

The Bazaruto Archipelago is arguably Mozambique's most important marine conservation area, where seagrasses provide important nursery areas for juvenile fish, while supporting the livelihoods of artisanal fishers, and represent the primary feeding areas for the Endangered Dugong (*Dugong dugon*). The EWT has implemented marine conservation work here for the past seven years. Most recently, we developed a bottom-up approach to Dugong and seagrass conservation. In collaboration with the Bazaruto Archipelago National Park (BANP) and the University of Eduardo Mondlane (UEM), we trialled an effective, non-invasive fish monitoring programme for the park, with a focus on seagrass ecosystems.

Our project team developed a baseline database for seagrass specific fish, while training a student from UEM and rangers from the BANP in the technique. This past year, we conducted two Baited Remote Underwater Video (BRUV) surveys, and counted 4,186 individual fish, from 102 fish species, in 37 families. In Zenguelemo, an island with relatively high fishing effort, we recorded significantly lower average fish abundances than at Matutile (which is more difficult to access), or Santa Carolina (which is a no-take zone), where the fish community was more diverse too. Our findings emphasise the success of the "No Take" zone, and limiting fishing pressure, and reinforce

the importance of such management zones in seagrass habitats and their benefits to fisheries, conservation and tourism. We are pleased to report that the BANP finalised a long-term partnership African Parks (AP), with the two signing a Memorandum of Understanding on 6 December 2017.

This global project is executed by the Mohamed bin Zayed Species Conservation Fund with financing from the Global Environment Facility, implementation support by United Nations Environment Programme (UN Environment) and technical support from the Convention on the Conservation of Migratory Species of Wild Animals (CMS) Dugong MoU Secretariat, with co-funding from the Elizabeth Wakeman Henderson Charitable Foundation.





Jacana chick

Cape Critical Rivers

The Cape Critical Rivers team, through the Freshwater Research Centre, continued to engage landowners in the Kouebokkeveld on the sustainable use of the region's scarce water resources. The drought experienced in the area over the past year is unprecedented. Besides its economic impact on local agriculture, this drought devastated freshwater ecosystems downstream. There needs to be much greater awareness about the value of water to downstream human communities and ecosystems, and more efficient water management practices are essential if the effects of these devastating droughts – which are likely to increase under predicted climate change scenarios – are to be mitigated. We are therefore promoting better water awareness and governance among both commercial and emerging landowners, with an emphasis on the importance of environmental flows to show that more sustainable land and water management is critical for the long-term viability of farming in the region.

In Barrydale, efforts to restore environmental flows to the Huis River, and to rehabilitate habitat for the Critically Endangered Barrydale Redfin (*Pseudobarbus burchelli*), have finally paid off. Through the efforts of the Cape Critical Rivers team, the principle of environmental flows was incorporated into the Barrydale Bulk Water Supply Scheme. Effectively, at least a

kilometre of river that previously stopped flowing for much of the year as a result of abstractions for the town of Barrydale, now has a permanent flow to support this indigenous fish population.

This project is executed by the Cape Critical Rivers team, with support from the Elizabeth Wakeman Henderson Charitable Foundation.



Healthy Catchment Alliance: Amathole Freshwater Species Conservation Project

The aim of this project is to protect and manage key freshwater and rangeland ecosystems, while at the same time stimulating change in conservation perceptions and driving local, inclusive and sustainable economies in these areas. The mountains and valleys of the Amathole Catchment are heavily infested with Black Wattle trees (*Acacia mearnsii*) that extract excessive water and modify terrestrial and aquatic habitats by competing with indigenous plant species, exposing the soil to erosion and excluding sunlight.

The EWT has been working to rehabilitate the Tyhume River system, home to two Endangered fish species, the Border Barb (*Barbus trevelyani*), and Eastern Cape Rocky (*Sandelia bainsii*). Preliminary fish surveys indicate that populations of the Border Barb are on the increase, with the number of sampled individuals doubling between 2015 and 2017. This shows that the value of rehabilitant wattle stands in the riparian zone, with a positive impact on the river habitat, favourable to the survival of these indigenous fish.

We treated 11 km of river, totalling 1,830 ha, and 150 households received increased income from project-related salaries between 2015 and 2018, totalling R2.7 million. Sixty percent of the beneficiaries were youth, 60% women, while 2% live with disabilities. In addition to supplying daily necessities, these earnings helped to provide supplies for schoolchildren, seed funding for home industry, medication and feed for livestock, and materials for building and renovations.

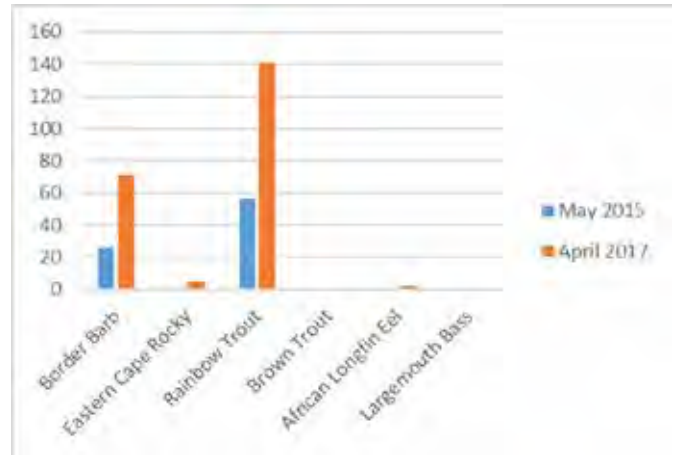

The populations of both the alien Rainbow Trout and the indigenous Border Barb increased in the last year in the Tyhume River



Conducting river health assessments

In South Africa, a challenge is balancing a development agenda that meets the needs of a growing population, with the conservation of ecological infrastructure. As such, catchment conservation often competes with other industries, while challenges such as poor land management, exacerbate the pressures on our natural resource base. In this context, beekeeping offers an ideal green economic enterprise, providing sustainable economic opportunities that support the healthy functioning of the environment. To date, we have trained 24 beekeepers in beekeeping, apiary management and financial management. Our project has retained 21 active beekeepers: eight in the Amathole catchment, two in the Mzimkhulu catchment and 11 in the Mzimvubu catchment

area. We will next negotiate conservation agreements with the beekeepers to implement sustainable environmental practices, and work with them to identify potential enterprise partners and business opportunities.

Governance plays a crucial role in the sustainable management of any catchment area. In the Amathole, we promoted a more inclusive form of governance through the Amathole Catchment Forum. Various national and local government departments, civil organizations, community structures, research and private sector institutions had their say in the development of the catchment forum's Terms of Reference that were finalised in the first quarter of the year.



Sustainable livelihoods in action



Before alien plant clearing



After alien plant clearing

What our stakeholders are saying

"This project has opened our eyes to a new way of thinking about our environment, the idea of keeping bees to make money never crossed my mind as I was afraid of the bees. Now I know if I respect them, they will respect me and I can supplement my livelihood with them and also help nature." Bongani Bavuma – Natural Resource Management contractor / beekeeper

"It is very interesting to learn about the different fish in our rivers, we didn't even know that there are fish in these rivers" Buhle Blom – NKonkobe Enterprise Development Agency Enviro student / EWT river monitoring volunteer

"What I like about the job is that we are preserving nature, we know what the state of the country is at the moment so we are trying to preserve as much water as we possibly can". Stella Baskiti-Jam – NRM alien clearing team member

This project is supported by the European Union, the Department of Environmental Affairs: Natural Resource Management Directorate and Rand Merchant Bank



Harvesting beetroot and spinach

Marico Catchment Conservation Project (A *Re Itireleng* – “Let’s Do It Ourselves”)

The upper reaches of the Groot Marico River fall in a region of South Africa that is a strategic water source area, a poverty priority area, and particularly vulnerable to climate change impacts. These waters support a high number of endemic invertebrate taxa, which, together with its free-flowing nature, has resulted in the Marico River and its catchment being listed as a National Freshwater Ecosystem Priority Area (NFEPA).

The EWT is working in the Marico River Catchment together with a consortium of organisations, including Mmutlwa wa Noko, Pathfinder International, WESSA, African Pride Nature Conservation Association, Koffiekraal Community Property Association, and Tikologo Permaculture Project. This trailblazing partnership – the first of its kind in South Africa – addresses eight of the 17 Sustainable Development Goals. The project is integrated, co-created with the affected communities, and centred on achieving long-term impact through Ecosystem-based Adaptation (EbA) to climate change.

Our goal is to protect the biodiversity and ecological integrity of the Marico River, while improving the lives of the people that live within the catchment. Over the past year, we worked with researchers from University of the Witwatersrand to assess the indigenous fish populations in the river, map out the distribution of the Marico Barb (*Enteromius motebensis*), and identify where invasive bass species (*Micropterus sp.*) present the greatest threat. We supported the local community to oppose ten unsustainable mining/prospecting applications in this groundwater source area, including four that were successfully opposed.

We developed and supported four climate-smart agribusinesses and green economy enterprises, with skills development and extension support for 25 local community champions. Through our partnership with Pathfinder International, we addressed the self-identified need of over 33,000 rural community members for access to improved reproductive healthcare and “Future Planning” (combined family planning, career development and life skills support).

This project is supported by the UNDP Coca-Cola New World Programme, the Leisure Charitable Trust, and the Elizabeth Wakeman Henderson Charitable Foundation.

Knysna Estuary Conservation Project

The Knysna Estuary is the most important estuarine system in South Africa, due to its biological diversity and habitats, zonal type, rarity and size. The estuary supports the largest population of Cape Dwarf-Eelgrass (*Zostera capensis*) in South Africa, a habitat that is vulnerable to extinction. This eelgrass habitat is essential for a number of rare and threatened species including the Endangered Knysna Seahorse (*Hippocampus capensis*) and the Critically Endangered Pulmonate/False Limpet (*Siphonaria compressa*). Here, the EWT works with local conservation organisation, the Knysna Basin Project, to support the ecological functioning of the Knysna Estuary and trial solutions to mitigate some of the threats.

Given that sediment and nutrient pollution are the primary threats to estuary health – exacerbated by the catastrophic fires in June 2017 – we began by investigating potential short-term mitigation interventions to supplement long-term goals. We have subsequently collected data at 19 storm water and river inlet points that allow us to prioritise interventions, and provide a baseline from which to measure their effectiveness.

After significant rainfall events, sediment hotspots include the Ashmead channel and Salt River while significant ammonia levels were recorded at the Waste Water Treatment Facility, Bongani and Salt Rivers. Our work was used to prioritise the placement of two biohaven floating islands. These have been used internationally with success to reduce sediment and nutrient loads entering a water body. We will measure the effectiveness of these islands as a short- to mid-term solution to this issue, and make recommendations the local authorities.



Cumulative nitrogen data to date: blue arrow indicates the Salt River where the biohaven islands are installed. (Alice Harvey, University of Cape Town).



Cumulative Total Suspended Solids data: blue arrow indicates Salt River where the islands are installed. (Alice Harvey, University of Cape Town)

This project is supported by Nedbank and Ryobi.

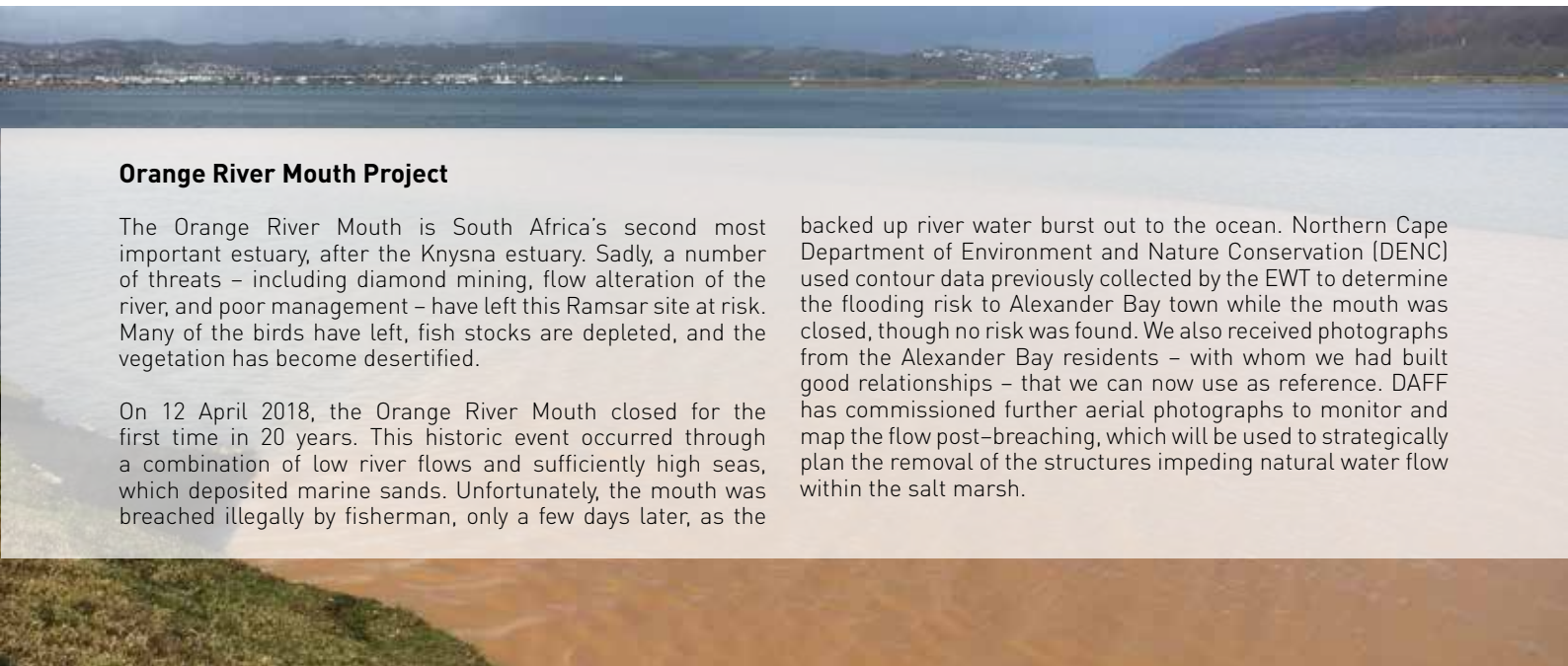

Orange River Mouth Project

The Orange River Mouth is South Africa's second most important estuary, after the Knysna estuary. Sadly, a number of threats – including diamond mining, flow alteration of the river, and poor management – have left this Ramsar site at risk. Many of the birds have left, fish stocks are depleted, and the vegetation has become desertified.

On 12 April 2018, the Orange River Mouth closed for the first time in 20 years. This historic event occurred through a combination of low river flows and sufficiently high seas, which deposited marine sands. Unfortunately, the mouth was breached illegally by fisherman, only a few days later, as the

backed up river water burst out to the ocean. Northern Cape Department of Environment and Nature Conservation (DENC) used contour data previously collected by the EWT to determine the flooding risk to Alexander Bay town while the mouth was closed, though no risk was found. We also received photographs from the Alexander Bay residents – with whom we had built good relationships – that we can now use as reference. DAFF has commissioned further aerial photographs to monitor and map the flow post-breaching, which will be used to strategically plan the removal of the structures impeding natural water flow within the salt marsh.

SOURCE TO SEA PROGRAMME TEAM



Bridget Jonker
Programme Manager



Grant Smith
Orange River Mouth Project
Field Officer



JP Le Roux
Marico Catchment Conservation
Project Coordinator



Nkosinathi Nama
Amathole Freshwater Species
Project Coordinator



Nicholas Armstrong
Eastern Cape Field
Operations Officer

Sustainable Development Goals



Aichi Biodiversity Targets



A legend for these icons can be found on pages 9–10.



To see the Healthy Catchment Alliance in action, and more, visit www.youtube.com/user/EWTSouthAfrica

SOUTPANSBERG

PROTECTED AREA



Creating a conservation haven in the magical Soutpansberg Mountains

South Africa's Soutpansberg Mountains contain some of the highest levels of endemic species and unique ecosystems in the world. Forming both core and buffer zones of the UNESCO Vhembe Biosphere Reserve, these mountains include six biomes, covering vegetation types that are found only in the Limpopo Province, or the Soutpansberg Mountains themselves. These mountains are also a strategic water source area (SWSA), part of the eight per cent of our land area that provides more than half of our surface water. They are thus an important water factory, given that South Africa is one of the 30 driest nations on earth and faces the increasing risk of drought and climate change. Protecting regions like the Soutpansberg is vitally important, both for their water production, as well as to conserve their unique biodiversity. Even so, less than one per cent of the Soutpansberg currently receives formal protection, and there is a critical need to formally safeguard more of this unique area.

The EWT recently embarked on a long-term project to realise the dream of establishing the Soutpansberg Protected Area (SPA), spanning 23,000 ha. The goal of the SPA is to contribute towards the safeguarding of globally Endangered species through local conservation efforts, while also supporting the development of sustainable livelihoods in the western Soutpansberg Mountains, a centre of cultural heritage for many communities.



The EWT currently has three projects running in the SPA: the Protected Area Expansion Project, the Anti-Poaching Project, as well as the SPA Water Conservation Project. Additional work includes research and community outreach.

Medike Nature Reserve

Medike Nature Reserve is in the heart of the western Soutpansberg, in the Sand River gorge. It spans over 1,400 ha, and is a haven for biodiversity. The EWT bought this property in February 2018, with a very generous donation from the Roberts' Family Trust.

As part of developing a management protocol for Medike Nature Reserve, we are updating the species list. Our preliminary list already emphasises the remarkable diversity of species within the reserve, which boasts at least 58 types of butterfly, 14 scorpions, 16 amphibians, 61 reptiles, 58 mammals, 228 birds and 236 different tree species.

On 4 December 2017, the Reserve recorded its first Schwarz's White-collared Monkey (*Cercopithecus albogularis subsp. Schwarzii*), an Endangered Samango Monkey subspecies occurring in the fragmented Mistbelt Forests of the Soutpansberg. This underscores Medike's importance as a wildlife corridor between wildlife populations east and west of the Sand River gorge. By securing this land parcel, the EWT is improving landscape connectivity, as well as the genetic viability of wildlife populations within the western Soutpansberg.

We formulated an Integrated Waste Management Plan for Medike, which included a litter clean-up campaign on our reserve, in which we reclaimed approximately one tonne of recyclable material. This was taken to a local recycling depot, benefiting previously unemployed women. To fulfil our reserve's energy requirements, we installed a solar energy system, which is in line with the EWT's 'off the grid' policy and, shows our commitment to 'walk the talk'. Our decision also meant that no overhead high voltage power line infrastructure was constructed, a potential threat to the Endangered Cape Vulture colony, of approximately 215 breeding pairs can be found less than three kilometres away.

The SPA is collaborating with the EWT's Wildlife and Transport Programme to gather baseline information on the ecological impact of the railway line that runs through Medike. The SPA anti-poaching unit (APU) successfully completed a road and rail ecology training course, which upskilled our field rangers, allowing them to assist with the railway impact study. The APU now collects wildlife mortality data on Medike's 3.7 km section of railway line, which appears to impact reptiles the most, as they represent three quarters of all recorded mortalities.

Protected area expansion programme

The EWT has been driving the Limpopo Province's Biodiversity Stewardship Programme in the western Soutpansberg, in collaboration with the Limpopo Department of Economic Development, Environment and Tourism (LEDET), and we reviewed and signed a Collaborative Project Agreement to improve landscape connectivity through Protected Area expansion. We identified and visited a number of potential biodiversity stewardship sites, together with LEDET's Protected Area Management officials. Consequently, the EWT engaged with several private landowners who own important properties in and around the proposed SPA. Our approach has paid off, as nine landowners have committed to become part of the Biodiversity Stewardship Programme, covering a surface area of 22,007 ha. Their foresight will help protect a number of highly threatened and locally endemic species.

Key threats to the unique biodiversity of the western Soutpansberg include:

- Illegal killing of wildlife for the local bushmeat and pelt industry, for example for skins of wildlife such as Leopard (*Panthera pardus*). Leopards here have shown a 66% decline in population density over the past eight years, mostly due to illegal snaring.
- Illegal killing of wildlife for export trade. Examples include the scales of Temminck's Ground Pangolin (*Smutsia temminckii*) and the horn of the Southern White Rhinoceros (*Ceratotherium simum simum*).
- Illegal and unsustainable harvesting of medicinal plants such as the Endangered Pepperbark Tree (*Warburgia salutaris*), as well as the uncontrolled collection of firewood (66% of which is for local households) in the area.
- Ongoing illegal sand mining in some parts of the Sand River for local house construction.
- Illegal fish poaching.
- Illegal clearing of indigenous forests for macadamia nut and avocado production, and to enlarge cattle grazing areas around the proposed SPA.
- Spreading of invasive alien plants, especially in the riparian zones along the banks of rivers, threatening freshwater biology, water quality, and the region's water security.

Anti-poaching Project

This year, our SPA team recruited, trained and deployed its first anti-poaching unit. The SPA Field Rangers have subsequently removed 94 snares, 15 fishing nets, seven fish traps and confiscated 70 kg of illegally harvested medicinal plants. In less than six months, the number of incursions into Medike declined by over 95%. We attribute this success to frequent day and night patrols, laying ambushes, and observation point work undertaken by our team. As part of the EWT's ongoing commitment to protecting wildlife, while at the same time assisting neighbouring communities to minimise livestock losses, we volunteered our ranger services to sweep the neighbouring communal land for snares. Our anti-poaching unit will continue to assist the reserve's neighbouring communities in creating a snare-free buffer zone. Fostering good neighbourly relationships in this way has led to members of the adjacent communities stopping their illegal sand mining activities in the river upstream from the reserve.



SPA Water Conservation Project

Supported by the WWF Nedbank Green Trust, the objective of the Water Conservation Project is to improve hydrological functioning through the removal of invasive alien plants. These plants pose a direct threat to biodiversity, as well as other ecosystem services such as the provision of water. Our project will also explore and catalyse priority biodiversity-friendly economic initiatives with local communities in the area, with a special focus on newly approved and potential land-reform property owners. Activities will include working with local communities to develop sustainable livelihood options that build resilience in the western Soutpansberg and support its ongoing ecological integrity, by providing jobs and income through social enterprise development.

The project kicked off in April 2018, with the appointment of Cath Vise as coordinator. Still in its early stages, and following invasive alien plant surveys across the western Soutpansberg, we have identified seven sites for invasive alien tree removal. We have mapped five of these sites in more detail, covering an area of 34 ha, which we will target for alien removal. We recruited our Water Ranger team, led by Elias Sithole. The team will eradicate alien plants in the SPA's river systems and carrying out rehabilitation work, to enhance the restoration of wetlands to their natural state. The dominant species that the Water Rangers will be working to clear include stands of Eucalyptus sp. as well as Acacia mearnsii. The SPA field rangers removed 5,542 invasive plants from Medike and worked on removing invasive alien plants from the Morning Sun Nature Reserve river system within the western Soutpansberg, removing over 200 invasive Black Wattle trees.

Our enterprise development work will target the Kutama Tribal Area, and we will be working with the Tribal Authority in an area directly downstream of some of our habitat restoration sites. These communities will benefit from both enterprise development initiatives, and from better water resources, as a result of our water conservation efforts.

What our stakeholders are saying

"Elias, of the EWT's Water Rangers, came to work with our team on the Morning Sun Nature Reserve, undertaking the eradication of black wattle in our river system. We found Elias to be knowledgeable on invasive species removal, friendly, efficient and a pleasure to work with. He showed us better ways of applying herbicide, in particular to avoid any contamination of the river system. We are very grateful to him and the EWT for his assistance and guidance in removing invasive plants" – JJ Joubert, Manager, Morning Sun Nature Reserve, Soutpansberg.

The SPA appreciates the support of the following major donors: The generosity of the Roberts Family Trust not only enabled the EWT to purchase Medike, but has also allowed the EWT to catalyse the vision that is the SPA. This has leveraged further support from major donors including Rainforest Trust, WWF Nedbank Green Trust and Phumelela Gaming.

The SPA received a Nissan NP300 Hardbody 2.5 TDi Double Cab Hi-rider on loan from NISSAN S.A. (Pty) Ltd. The vehicle has opened up a tremendous number of opportunities that will allow us to support local communities while protecting our natural environment.



OVER 1 TONNE

of recyclable material recovered from Medike Mountain Reserve and taken to a local recycling depot

9

LANDOWNERS with over 22,000 ha of land, committed to participating in Biodiversity Stewardship

5,542 invasive plants removed from Medike

1 PROPERTY (1,400 ha) purchased and owned by the EWT

Mozambique Spitting Cobra, Medike Nature Reserve

Community outreach

As part of our commitment to empower the next generation to live a sustainable lifestyle, the EWT's Field Rangers, in collaboration with the WESSA's Eco-Schools programme, made three visits to schools in the neighbouring tribal area, and conducted environmental education sessions in the form of picture building games, focusing on communities neighbouring protected areas. Our rangers shared with children the professional work they do to conserve Africa's wilderness in order to inspire and develop the next generation of rangers.

The SPA team constructed a 1.5 km tree identification trail, marking indigenous trees with tree tags stating the tree number,

scientific name and common names in English, Afrikaans and Tshivenda or Sepedi. This trail has been established as part of the SPA outreach programme to the neighbouring tribal area. The 2018 High School Cycle Tour, from Beitbridge (Musina) to Stanford Lake College (Tzaneen) cycled through the EWT's reserve, using Medike's Pioneer Cottage as a rest stop. Twenty-three cyclists, representing schools from Louis Trichardt, Polokwane, Mokopane, Tzaneen and Phalaborwa, participated in this leg of the race. The region's cycle community was extremely grateful to the EWT for making our scenic reserve available for such a positive event.

SOUTPANSBERG PROTECTED AREA TEAM



Oldrich van Schalkwyk
Programme Manager



Catherine Vise
Water Conservation Project Coordinator



Elias Elvis Sithole
SPA Water Ranger



Khathutshelo Mukhumeni
Field Ranger



Kgotatso Lekhoane
Field Ranger



Johanna (John) Mohlolo
Field Ranger



Tharollo Mthisi
Field Ranger

Sustainable Development Goals



Aichi Biodiversity Targets



A legend for these icons can be found on pages 9-10.



To discover how removing alien invasive plants makes a massive conservation impact, and more, visit www.youtube.com/user/EWTSouthAfrica

THREATENED AMPHIBIAN PROGRAMME



Kloof Frog with eggs. Photo credit Richard Boon

For frogs' sake

The EWT, through its Threatened Amphibian Programme, is the only NGO in South Africa to include frogs as a conservation focus. Using threatened frog species as flagships for the conservation of important freshwater and terrestrial habitats, we implement species and habitat monitoring, initiate habitat protection strategies at important amphibian areas, improve management of important amphibian habitat, use research to support conservation action, and promote social change to galvanise behavioural change towards frogs and recognition of the importance of their habitats.

We aim to:

1. Elevate the conservation importance of frogs and their freshwater and associated terrestrial habitats within southern Africa.
2. Bridge the gap between research and on-the-ground conservation action by supporting and implementing relevant research projects.

3. Implement conservation actions that align with global amphibian conservation goals.
4. Drive social change to promote behaviour that supports sustainable natural resource use to the benefit of amphibians and their habitats.

At a global scale, our work contributes directly to putting into action the objectives outlined in the Amphibian Conservation Action Plan (ACAP, 2007), which is a high-level, cross-disciplinary strategy to address amphibian conservation needs. The ACAP is the most ambitious programme ever developed to combat the extinction of species and offers practical, large-scale, creative, innovative and realistic actions that are required to halt the present tide of extinctions of amphibians.

Monitoring

Amphibians around the world are experiencing dramatic population declines, mostly as a result of habitat loss, but also due to insidious threats such as climate change and disease. In the absence of long-term monitoring, it is impossible to detect trends in population dynamics, and identify the causes of these. If we know what is causing population declines, we can intervene with the appropriate conservation measures to address threats and halt – or reverse – declines. Through our projects, we are currently actively monitoring four threatened species.

We now have five years of monitoring data for the Endangered Kloof Frog (*Hyperolius marmoratus*) from Vernon Crookes Nature Reserve, in KwaZulu-Natal, and three years of data from Crowned Eagle Conservancy in Gillitts, KZN, as well as three reserves in the Eastern Cape (Silaka, Hluleka and Dwesa-Cebe Nature Reserves). We use egg clutch counts to monitor the breeding activity of this species, which lays distinctive egg clumps that they attach to leaves, branches or rocks above the water.

Our monitoring shows that the Kloof Frog is most active between September and February, and that breeding productivity is strongly linked to rainfall. It has also been promising to see that, at our monitoring sites, breeding strongly recovered after the 2015/16 drought with an average of only 25 eggs per egg mass to pre-drought levels in the past year (45 eggs per mass). We have used Passive Acoustic Monitoring to record the breeding calls of male frogs of the Endangered Pickersgill's Reed Frog (*Hyperolius pickersgilli*) at three sites along the KZN coast over the past three years, and trialled this method for the first time in 2018 for the Endangered Long-toed Tree Frog (*Letropelis xenodactylus*) in the KwaZulu-Natal Midlands, in collaboration with Ezemvelo KZN Wildlife.





Pickersgill's Reed Frog Forum



Taking part in the Bioblitz

Mitigating threats

In June 2017, the government promulgated a Biodiversity Management Plan for Species (BMP-S) for the Endangered Pickersgill's Reed Frog. This is the first such plan to be published for a threatened South African frog.

A BMP-S is an action plan outlining conservation actions needed to address the key threats facing a severely threatened species, and is provided for through the National Environmental Management: Biodiversity Act, 2004 (Act No. 10 of 2004) (NEMBA).

The EWT and Ezemvelo KZN Wildlife worked together to initiate and write the BMP-S, and are actively implementing the interventions laid out in the plan, including strengthening partnerships, improving understanding of the species, and discovering new subpopulations, all of which helped us to down-list the species from Critically Endangered to Endangered in 2016. The objectives of this plan are being actively incorporated into municipal planning frameworks, including Spatial Develop Frameworks (SDFs) and Environmental Management Frameworks (EMFs).

The first Pickersgill's Reed Frog Forum was held on 20 April 2018. The forum was established as part of meeting the

objectives of the BMP-S, and for partners to report on progress towards implementation of the plan. This was jointly organised with Ezemvelo, which is the Lead Agent, with the EWT as the Lead Implementing Agent. Seventeen delegates representing ten organisations attended, including from industry, ex situ facilities, consulting and the private sector.

We contributed expert knowledge towards the National Biodiversity Assessment coordinated by SANBI (for publication in 2019) to understand the levels of protection for South African amphibian species. Of the 130 species assessed, nearly a third of South African amphibians (28%) fall outside of being 'Well Protected', while 8% of species are classes as 'Not Protected'. The situation is worse for species endemic to South Africa (84 species), of which 44% are not 'Well Protected' (Table below).

We used this exercise to determine the Red List Index (RLI) for South African frogs to examine the changes in species' conservation status between Red List assessments from 2004, 2009 and 2015. The analysis showed a small decline in the RLI over time, with an overall 1% reduction in RLI since 1990, due almost entirely to habitat loss and degradation.

South African amphibians and their protection levels according to IUCN Red List criteria. Total species numbers (and percentages) are given together with species which are endemic or nearly endemic (> 90% are inside South Africa, Lesotho and Swaziland) to the region.

Category	CR	EN	VU	NT	LC	DD	Endemic	Total (%)
Well Protected	0	1	0	6	81	5	47 (56%)	93 (72%)
Moderately Protected	0	1	0	3	6	0	10 (12%)	10 (8%)
Poorly Protected	3	5	0	1	6	1	16 (19%)	16 (12%)
Not Protected	3	2	1	2	0	3	11 (13%)	11 (8%)
Total	6	9	1	12	93	9	84	130

CR – Critically Endangered, EN – Endangered, VU – Vulnerable, NT – Near Threatened, LC – Least Concern, DD – Data Deficient



Site Guides conducting MiniSASS at Adam's Mission



Site Guide KZN Frog Route logo



Searching for Amathole Toads on Elandsberg Mountain, Hogsback

Habitat rehabilitation and management

This year, we cleared alien invasive plants and rehabilitated 610 ha of wetland and coastal habitat at four Pickersgill's Reed Frog sites in the greater Durban area, namely Widenham, Isipingo, Adam's Mission and Mount Moreland, in the process creating employment for 71 local community members.

We entered into Conservation Agreements with local community committees to promote sustainable green livelihoods options, for example wetland-friendly gardening at sites at which Pickersgill's Reed Frog occurs to reduce direct impacts on wetland habitat.

We conducted Ecological Goods and Services (EGS) assessments across 90 ha of wetland habitat in the ILembe District Municipality and eThekweni to assess wetland health, improve our understanding of threats facing these sites, in the process provided training and employment to 16 local community members. With support from ICLEI, we developed an alien plant management plan in collaboration with the relevant municipal department from ILembe, one of whom we have assisted in setting up a local business to manage an alien clearing project that we will implement in the next financial year.

Through the support of Rainforest Trust, we were able to employ two new programme staff members from the Adam's Mission community as Biodiversity Protection Officers. These officers will conduct ongoing EGS assessments of the wetland and riparian habitat at this site, support habitat protection efforts and report on emerging threats. They will engage with the community living in the vicinity of the wetland to understand attitudes to biodiversity, especially frogs, learn more about local natural resource use practices and improve our understanding of the threats facing the system, for example waste management.



Site meeting at Isipingo wetland box gardens



Isipingo schools engagement at Themela Primary – wetland assessment survey

Habitat protection

The first protected area for the Critically Endangered Amathole Toad

Supported by Rainforest Trust, and in collaboration with Eastern Cape Parks and Tourism (ECPTA), Glenara Farm near Hogsback was approved for Nature Reserve category through the Biodiversity Stewardship process, in March 2018. This represents the only formally protected area where the Amathole Toad (*Vandijkophrynus amatolicus*) is known to occur. This is a huge achievement in the conservation of this highly localised species. The site will now be known as the Elansberg Nature Reserve.

Community conservation for the Endangered Pickersgill's Reed Frog and Kloof Frog

We have been working extensively in Adam's Mission area south of Durban, with the support of Rainforest Trust, to establish a good working relationship with the local traditional leaders to manage and protect the extensive coastal wetland and swamp forest that occurs here. This habitat supports two Endangered frog species the Pickersgill's Reed Frog and Kloof Frog, as well as a rich diversity of plants and birds. In June 2018, two local Indunas of the Makhanya Tribal Authority signed a 'Biodiversity Agreement' towards protection and management of 78 ha of wetland and swamp forest in the Adam's Mission area – a first step in conserving this threatened habitat and the species it supports.



Biodiversity Stewardship survey



Adam's Mission Nature Site Guides

Awareness

Through a social change strategy, our programme has established projects that support amphibian conservation through social interventions as part of wetland management along the KZN coast. These interventions include direct employment through alien plant eradication and wetland rehabilitation activities, establishment of ecotourism opportunities, and the use of conservation agreements to address food security using conservation-friendly agriculture, while minimising direct impacts on wetlands. Exploring the effectiveness of these interventions using both formal and informal approaches, forms the basis of understanding the role that conservation programmes can have in initiating positive social change.

In February 2018, we coordinated the fourth consecutive Leap Day for Frogs, which is an annual campaign that celebrates South African frog diversity, highlights their plight and

encourages the public to take a leap of action for frogs by becoming involved in some kind of frog-related activity. The total number of people participating in Leap Day for Frogs 2018 was over 6,000 countrywide, represented by 30 organisations, schools, individuals, and companies. We devised a social media marketing campaign with Artifact Advertising, which ran in the weeks preceding Leap Day for Frogs; the main theme for this year was 'Dress in Green' for frogs through civvies days at schools and businesses.

During the last week of February, our staff spoke to over 400 people at various Leap Day activities. We once again partnered with Kloof Conservancy at Tanglewood Nature Reserve in Kloof for a Back-to-Nature Frog Evening of educational activities and frog searching, with 212 people attending, raising over R5,000 for the programme.



Monthly social media posts reaching over
20,000 people



11

educational
regional frog posters
developed, covering all
provinces

Our educational
video on frog
calls has been
viewed over

**131,000
times**





The Endangered Kloof Frog

What our stakeholders are saying

We helped set up a small enterprise 'ILembe Environmental Services' with Xolile Mahlobo from Nyoni in the ILembe district who we employed as a Biodiversity Officer through the ICLEI project. She had this to say about the opportunity:

"Thank you for the opportunity, this project means a lot to me, it is breaking locked doors as I have been unemployed for three years. This is a great opportunity and an achievement as well. To my family it also means a lot as because I am the first woman in my age to receive this amazing opportunity at my home as well to my community. There is a big change that is going to take place especial financially, now I am going to take a full responsibility of myself as well as for my family, the hope about the life is now coming back to me, the family is feeling so proud to have me and they thank you a lot Endangered Wildlife Trust. I see this change of life not only to me and my family but also to my community at large as because new job opportunities will come as well as the development in their community will take place. I thank you, EWT and I promise that I will do my best to make this project to be very successful."



Amathole Toad. Photo credit Werner Conradie



Tree Frog snoozing in a nest

THREATENED AMPHIBIAN PROGRAMME TEAM



Dr Jeanne Tarrant
Programme Manager



Cherise Acker
NRM Operations
Field Officer



Jiba Magwaza
Assistant Field Officer



Nonkululeko Nzama
Biodiversity Protection Officer



Njabulo Gcabashe
Biodiversity Protection Officer

Sustainable Development Goals



Aichi Biodiversity Targets



A legend for these icons can be found on pages 9-10.



To learn how we encourage communities to protect amphibians and their habitats, and more, visit www.youtube.com/user/EWTSouthAfrica

THREATENED GRASSLAND SPECIES PROGRAMME



Healthy grasslands: vital for food and water security

Grassland species and habitats are widely threatened by mining, agriculture and urban development. The Threatened Grassland Species Programme implements conservation action, research, capacity building and partnerships towards ensuring the resilience of grassland species, their habitats and the vital ecosystem services these provide to society.

Through conservation action for priority grassland species the Threatened Grassland Species Programme, maintains

resilience of ecosystem services provided by grasslands to ensure food and water security for society. These services include water supply and quality, soil fertility, clean air and carbon sequestration.

We inspire and empower landowners to take ownership of conservation-friendly land management on their properties using threatened, endemic and specialist grassland species as flagships.

Using sport to benefit wildlife

The EWT's Samson Phakathi has interacted for many years with a wide range of stakeholders to promote sustainable grassland management and discourage illegal harvesting of wildlife such as the Endangered Oribi antelope (*Ourebia ourebi*). Given that much of the illegal hunting activity is driven by the competitive nature of people, Samson has discovered the power of sport as an alternative to hunting with dogs, as well as a mechanism for increasing awareness. His Mpophomeni Angling Club has continued with great success, while his football team played a match to raise money for a mobile phone to be used for reporting poaching incidents. Recently, Samson and community members in Howick took up mountain biking. As a lead up to an inaugural community-based cycling event in an impoverished part of Pietermaritzburg, Samson engaged with the local community about the illegality of hunting without permits. The community borders the Baynesfield Estate, where poaching with dogs is rife. The Mpophomeni Cycling Club, which has 43 members, took part in several MTB cycle races across the KwaZulu-Natal Midlands. These include amongst others, the PSG Absolute Hilton Challenge, the SAPPI Karkloof Classic Trail Festival and the Howick Highlander MTB. This cycling initiative is in the process of being formalised, and a club constitution has been developed, which highlights, amongst other things, the need to use sport to promote healthy lifestyles and highlight environmental issues.

Samson continues to collaborate with Mark Lederle, a strong supporter of community engagement as a means of addressing sensitive environmental issues like poaching. To this effect, they have been working together under the Queen Elizabeth Park Honorary Officer Group (QEPHO) to develop strategies to address poaching with dogs within the Greater Pietermaritzburg area.

Supported by NCT Forestry Co-operative Limited and Farmers Agri-Care, and special thanks to Blue Security. We extend our thanks to SACAN, the KZN Hunting Shooting and Conservation Association, Ezemvelo KZN Wildlife, Project Rhino KZN, Conservation Outcomes, WESSA and FreeMe, with whom we have an ongoing partnership towards combating illegal hunting in KwaZulu-Natal.



Oribi





Unbuttoning the truth about secretive Sungazers

Sungazer lizards (*Smaug giganteus*) have been Fraser Gilchrist's passion for many years. Fraser is a reptile enthusiast who coordinates the European Studbook for Sungazers and. He sourced and delivered iButton devices to our team for research into the climatic requirements of Sungazers. These devices now record temperature and humidity conditions on an ongoing basis. We deployed the data loggers on eight farms in the Harrismith, Roadside (Vrede), Edenville, Welkom, Arlington and Reitz areas in the Free State, and the Volksrust area in Mpumalanga. We identified five of these seven areas as being vitally important for the long-term conservation of Sungazers, which are endemic to South Africa. Data from these devices will help us to understand the environmental conditions that Sungazers require for survival. The EWT is grateful to Fraser for his assistance in this research, and his ongoing passion for Sungazer conservation.

Fraser can be contacted on info@saveoursungazers.com and manages the website www.saveoursungazers.com.

KwaZulu-Natal Cycad Conservation Project

Cycads are the oldest living seed plants and have survived three mass extinction events in the earth's history but they are facing a growing threat of extinction. Cycads are now the most threatened group of organisms. South Africa is one of the world centres of cycad diversity, with 39 species. It is also one of the global hotspots for threatened cycads: 68% of South Africa's cycads are threatened with extinction compared to the global average of 62%, and 31% from South Africa are classified as Critically Endangered, compared to the global average of 17%. South Africa also has three of the four species classified as Extinct in the Wild, two of which have become Extinct in the Wild in the period between 2003 and 2010.

During our work to conserve KwaZulu-Natal's threatened cycads during 2017, we identified a number of issues. Upon visiting a stronghold of the cycad (*Encephalartos natalensis*) in northern KwaZulu-Natal in early 2018, we were fortunate to discover a stronghold of the Critically Endangered Ngotshe Cycad (*E. aemulans*), and we are now able to initiate conservation actions to protect this population. Properties in the surrounding area have reportedly lost their cycad populations due to poaching for domestic trade, as well as for traditional medicine. We partnered with the EWT's Wildlife in Trade Programme to conduct law enforcement capacity building with regard to cycads, and the team held a successful series of workshops with the South African Police Service (SAPS) and other provincial authorities on cycad removal and trade.

Given that cycads are extremely popular in many residential estates in South Africa, our team has embarked on a campaign to raise awareness with estate residents. The demand for cycads – which may have been illegally removed – for domestic use is often due to the ignorance of buyers around the legislation and procedures for purchasing cycads, known as the 'innocent buyer' concept. We will continue to devote attention to promoting the legislation governing cycad trade, and the permitting procedures.

Supported by the Carter Cycad Foundation Trust.





Protecting the lesser known parts of the Drakensberg

We launched our Eastern Great Escarpment Project in mid-June 2017, focused on developing private protected areas through the Biodiversity Stewardship mechanism. Located in northwestern KwaZulu-Natal, adjacent to the existing Ncandu Nature Reserve and the Ncandu Private Forest and Grassland Reserve, our focus area is characterised by the Endangered Eastern Mistbelt Forest vegetation type, of which only 15.5% is protected, as well as the Vulnerable Northern KwaZulu-Natal Moist Grasslands, of which only 1% is formally protected.

Landowners from this area, whose combined properties cover more than 13,000 ha of high quality grassland, have indicated their intent to join the stewardship process. In addition, a 1,230 ha section of this part of the escarpment has been proposed as a Nature Reserve, and the proclamation process is proceeding under the guidance of the provincial authority, Ezemvelo KZN Wildlife, and the KZN Biodiversity Stewardship Forum. We identified key stakeholder communities and their needs in terms of capacity building and support, and threats to the region including applications for shale gas exploration and invasive alien tree hotspots, that we aim to target for clearing in the future. Samson Phakathi has employed his exceptional community engagement facilitation skills to make contact with tribal authorities and reach out to the local people along the escarpment with regard to sustainable management of their land.

Supported by the Whitley Fund for Nature and Rand Merchant Bank.



Custodianship (as described in the EWT's National Guidelines for Custodianship in South Africa) is the recognition of voluntary commitment to the conservation of intact habitat and threatened species. Custodians, usually private landowners, are behind a significant amount of biodiversity conservation in the matrix of land outside of protected areas. Custodians are our champions on the ground, who spread the word about the need to conserve our natural resources. We are incredibly grateful to these passionate individuals and they deserve recognition for their significant contribution to conservation.

Biodiversity Stewardship is a national programme for the formal proclamation of privately-protected areas. These properties remain under the ownership of the private landowner, but are formally recognised as protected areas (usually Protected Environments or Nature Reserves, the latter being the higher category, but with both signed into the property title deeds). These are always associated with a negotiated management plan, which, in the case of Protected Environments, strategically governs continued production on the land while still protecting priority areas and species, and for Nature Reserves, these management decisions are more strongly focused on habitat and species protection.





900

Learners reached by our programme this year in Welkom, Odendaalsrus, Harrismith, QwaQwa, Dundee and Lüneburg on the subject of the poaching of grassland species. The team interacts Dundee and Lüneburg on the subject of the poaching of grassland species. The team interacts regularly with policemen and representatives from government departments to assist with capacity building with regard to grassland species poaching.



5

Suspects who appeared in court in the Free State for being in the possession of a Sungazer. The EWT team provided more information regarding Sungazers at the court case, and was pleased that this sets a precedent for the authorities to treat poaching cases seriously

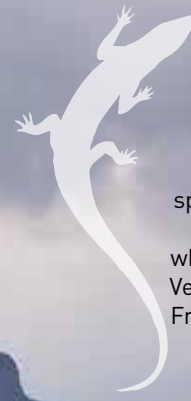

55

Sungazer burrows spotted by the Sungazer Working Group team who walked 15 km in the Verkykerskop area of the Free State on Valentine's Day 2018

What our stakeholders are saying

“Thank you both for the final report and for all your efforts and hard work, please pass on our thanks to the whole team.” – Nida Al-Fulaij, Grants Manager, People’s Trust for Endangered Species

“Congratulations on the approval of the new Nature Reserve and on securing additional funding! It was encouraging to read of the letters of intent from 11 landowners encompassing more than 9,300 ha. The map you provide is really helpful to see how this all fits together to form a corridor. Congratulations again on a successful six months. I found your reporting style strong, telling the reader the required information clearly and succinctly, thank you.” – Danni Parks, Deputy Director, Whitley Fund for Nature

“An extremely important component of our Touching Lives Programme, over the last five years, has been N3TC’s corporate membership of, and project partnership with, the EWT. The Highland Grassland Conservation Project, conserving Sungazers, their habitat and associated biodiversity, is central to the partnership. N3TC wishes nothing but the best for this Project and the organisations and individuals who protect and give voice to these iconic reptiles.” – Con Roux, N3 Toll Concession



Sharing our work with the next generation



Doing field work near a Sungazer burrow



Searching for Sungazers



Searching for Sungazers

THREATENED GRASSLAND SPECIES PROGRAMME TEAM



Catherine Hughes
Programme Manager



Mauritz De Bruin
Field Officer



Bradley Gibbons
Highland Grassland
Field Officer



Simon Phakathi
Assistant Field Officer

Sustainable Development Goals



Aichi Biodiversity Targets



A legend for these icons can be found on pages 9–10.



To find out why protecting our grasslands is vital for food and water security, and more, visit www.youtube.com/user/EWTSouthAfrica

URBAN CONSERVATION

PROGRAMME



Bringing our cities to life

Our purpose is to encourage urban residents to rediscover their link to nature, and to conserve and reduce threats to biodiversity and the remaining green spaces in urban areas, for the benefit of people and wildlife, now and into perpetuity.

Many urban people have forgotten that no matter where we live, we are completely reliant on the natural environment and the vital services it provides for our survival. Studies have shown that people who live in or near green areas have better physical and mental health. We aim to reconnect people with the natural environment and help them to see that they are part of the larger ecosystem, and that it is their responsibility to protect it. We want to show people the direct link between a healthy environment, healthy people and a healthy economy, to ensure that current and future generations are fully able to experience all the benefits and wonder of wildlife and the natural environment – both in cities and outside of them.

Training the guardians of our future

Our Guardians of the Future Project includes the implementation of the WESSA Eco-Schools Programme (hereafter Eco-Schools), as well as our own education and awareness raising campaigns in other schools and communities in urban and peri-urban areas. Capacity building in green enterprises, and sustainable socio-economic development, are vital components of building our army of guardians. The Eco-Schools Programme is an extensive and hands-on, internationally recognised, environmental education programme that focuses on improving environmental management within schools. The programme promotes environmental learning and provides opportunities for students and educators to improve and empower their schools and communities at large. With generous support from Bakwena N1/N4 Toll Concessionaire, we have supported ten Eco-Schools in Hammanskraal since 2013, and we implement the programme in two schools in Alexandra. Presently, the programme benefits more than 10,200 learners and over 300 teachers, as well as countless parents and other community members.

Throughout the year, we hold teacher workshops, assist schools to implement action projects, celebrate environmental days such as Arbour Day, and ensure that they are documenting all activities and achievements in their portfolios of evidence. At the end of each year, WESSA assesses these portfolios to ensure that the programme is having a positive impact on the environmental management of the school, and that projects are implemented effectively. For schools to receive an award, these portfolios must demonstrate that relevant subject matter was integrated into the school curriculum through multiple lesson plans, that children were actively involved in all aspects of their project, and that the project yielded some tangible result, such as having a growing vegetable garden or working recycling system in place.

In the past year, we received a 100% pass rate with all 12 of our schools, three of which received a Green Flag for successfully completing three themes and showing consistent involvement over three years. This flag can be hoisted alongside their school flag, identifying them as an official Eco-School. Two schools obtained Gold awards for completing four themes and action projects, and one of our schools was awarded an internationally recognised symbol of excellence, the Eco-Schools Flag, for successfully completing five themes and action projects over as many years. Action projects included growing food gardens to contribute to school feeding schemes or for additional income for the schools; recycling initiatives, using EcoBricks to construct much needed infrastructure (such as benches and walls around their veggie gardens); and water and electricity saving activities.

One of our objectives is to implement a number of sustainable, capacity building initiatives that will create additional opportunities for schools and community members to generate income for themselves. One such initiative that we have introduced, in partnership with the Clothes to Good campaign, upskills entrepreneurs to sell donated second-hand clothes. Clothes to Good conducts short training sessions with participants, teaching basic sales and business management skills. One of the mothers of a learner in Phelang Learners with Special Educative Needs, was enlisted in the programme. Having to provide additional care for her disabled son, the initiative has assisted her to generate income – over 100% profit on her first batch of clothes – to ease her load. We aim to empower more women and youth in this and other communities, unlocking various small enterprise development (SED) opportunities.



A city lifeline: Modderfontein Reserve

Modderfontein Reserve not only protects indigenous fauna and flora, but also provides an attractive green space within the urban edge where visitors can come and enjoy natural beauty that is close to home. The reserve continues to be a popular spot for activities like walking, cycling, running, picnicking, fishing, and birding. The reserve's education and outreach component is growing from strength to strength. Within the last year, the reserve hosted 16 scout groups made up of 596 scouts, and five schools comprised of 49 learners.

With ongoing support from the Modderfontein Conservation Society (MCS), we conducted 24 interactive walks, 12 bird walks, and in collaboration with the Gauteng Northern Region's Bat Interest Group, organised a bat talk and walk at the Education Centre with a turnout of 83 enthusiastic citizen scientists. These events emphasise how important this green space is to urban residents, and how much biodiversity can be found in the middle of the city. Throughout the year, there have been magnificent sightings of our national bird, the Blue Crane (*Anthropoides paradiseus*), and several specials such as the African Harrier-hawk (*Polyboroides typus*), White Stork (*Ciconia ciconia*), European Roller (*Coracias garrulous*), Red-footed Falcon (*Falco vespertinus*), European Honey Buzzard (*Pernis apivorus*), Eurasian Hobby (*Falco subbuteo*), Lizard Buzzard (*Kaupifalco monogrammicus*), and African Fish Eagle (*Haliaeetus vocifer*). We even have records of Bush Pigs (*Potamochoerus larvatus*), caught on camera traps, while spraints show the presence of otters on the reserve too.

Due to the reserve's unique location and history, the EWT plays a vital role in ensuring that impacts of the burgeoning nearby development activities are minimised and remedied. In turn, the EWT is using the management lessons learned to develop a model for the effective management of reserves within urban contexts as ecologically, educationally, economically and socially sustainable entities.



Veld condition assessment

The Gauteng Biodiversity Stewardship Programme

Gauteng is South Africa's largest economic hub, and is developing rapidly. While much of the province has already been transformed for agriculture, industry, commerce, homes, recreation and associated infrastructure, there are large areas that remain intact. These areas are of high biodiversity value and essential in the provision of ecosystem services. The Gauteng Biodiversity Stewardship Programme (GBSP) was established in August 2015, to protect these areas, while still ensuring that, where necessary, they can still be utilised sustainably for agriculture, recreation and tourism activities. The GBSP is a partnership between the Gauteng Department of Agriculture and Rural Development (GDARD) and the EWT, and is funded by the WWF Nedbank Green Trust. The purpose of the programme is to capacitate the GDARD to implement Biodiversity Stewardship (BDS) in Gauteng (see page 66 for explanation of BDS). The objective of the programme is to

conserve vital ecological processes, habitats and threatened species in Gauteng, and contribute at least 5,000 ha to targets set out in the Gauteng Conservation Plan (C-Plan) version 3.3, GDARD's mandate, and the National Protected Area Expansion Strategy.

The GBSP team has built on the momentum achieved over the previous reporting period, moving steadily through the early stages of the declaration process for our first Nature Reserve site, and initiating the process at several other proposed Protected Environments. The capacity of the GDARD team members has been developed significantly, and their understanding of the legal and technical aspects of BDS is vastly improved. With increasing confidence in the programme, the GDARD has provided the BDS unit with an additional team member who has extensive protected area operations and

management experience. Our relationships with landowners, stakeholders, other NGOs, the media, as well as provincial and national authorities, continue to grow as the GBSP progresses. We have engaged extensively with all of our landowners throughout the process, ensuring that the GDARD gains their trust and respect, so that there remains a strong relationship between GDARD and the landowners after the closure of this project.

Over the past year, our declaration processes have advanced well. The GDARD has approved and signed the Proposal to Declare documents for five protected areas comprising 15,367 ha, of which 9,700 ha is untransformed. We presented the owners of all of these sites with the legal contracts and associated documents required for declaration, with one of these landowners signing his contract, allowing us to proceed with the declaration of his property as a Protected Environment. We are optimistic that, even if a number of our sites do not proceed, we will achieve our target of 5,000 ha. Should all of our engaged sites be declared, we will exceed our target by 300%.

A significant highlight for the GBSP team was being awarded the 2017 Mail and Guardian's Greening the Future Award in the Community Conservation and Resilience Category. We received welcome exposure for the project through this achievement, and the team was afforded well-deserved acknowledgement of their hard work within a difficult landscape.



Tree planting



Burning fire breaks

What our stakeholders are saying

"This WWF Nedbank Green Trust project, funded through the Nedbank Green Affinity Programme, complements Nedbank's brand identity as 'money experts who do good,' as it highlights different spheres of value that are essential to our lives and livelihoods," – Yvonne Verrall, Nedbank Marketing Manager: Green Affinity, Green Leadership and Sustainability.



URBAN CONSERVATION PROGRAMME TEAM



Emily Taylor

UCP & Gauteng Biodiversity Stewardship Project Coordinator



Zethu Sibiya

Eco-Schools Programme Intern



Boaz Tsebe

Modderfontein Reserve Manager



Shumani Makwarela

Modderfontein Reserve Field Officer

Sustainable Development Goals



Aichi Biodiversity Targets



A legend for these icons can be found on pages 9-10.



To discover how our work in schools impacts on teachers, learners, and communities, and more, visit www.youtube.com/user/EWTSouthAfrica

VULTURES

FOR AFRICA



Saving the most extinction-prone animals in the world

The Vultures for Africa Programme implements appropriate conservation actions for vultures, particularly species within southern and East Africa. This reflects the Convention on Migratory Species (CMS) recent Multi-species Action Plan for African–Eurasian Vultures (Vulture MsAP). A primary focus of this action is to work towards reducing the impact of wildlife poisoning on vultures and other wildlife through Africa, and to focus on innovative approaches to vulture conservation.

White-backed Vulture

Programme strategy and partnerships

In December 2017, the EWT signed a three-way partnership with the Hawk Conservancy Trust and the University of Reading to support our work focused on reducing the impact of wildlife poisoning on wildlife in southern and East Africa. This provided additional impetus to the EWT's current work, and places greater emphasis on filling knowledge gaps, and creating greater capacity with regard to the research and monitoring of vulture populations in the region.

One of the programme's most significant achievements was the completion of our contract with BirdLife International for the successful adoption of the CMS Vulture MsAP by all 128 range countries at the twelfth Conference of the Parties of the Convention on Migratory Species, held at Manila, Philippines in October 2017. Programme Manager, André Botha, was contracted as Overarching Coordinator for this project, which was completed within tight deadlines and successfully passed

scientific peer-review, prior to publication and its submission for adoption. The Vulture MsAP will provide a framework to guide vulture conservation action across three continents, focused on 15 species of Old World vultures, over the next 12 years.

We held our first two workshops, in partnership with the Socio-ecological Synthesis Centre (SESYNC) of the University of Maryland, in Annapolis, Maryland, USA in October 2017 and May 2018. These brought together a core team of vulture conservationists and scientists from a range of academic, governmental and non-governmental institutions in southern and East Africa to deliberate over new, innovative approaches and interventions with regard to the conservation of these endangered birds. A further two workshops are scheduled for October 2018 and March 2019.

Wildlife poisoning intervention

The programme presented 14 poisoning intervention training courses, through four countries in southern Africa, to 381 individuals.

Details of poisoning intervention training courses held in 2017/18

Country	Training events	Female	Male	African	Other	Total
Zambia	3	11	68	75	4	79
Malawi	3	1	94	90	5	95
Namibia	1	6	15	7	14	21
South Africa	7	69	117	123	63	186
Total	14	87	294	295	86	381

In November 2016, we conducted a three-day workshop, in the Maasai Mara National Park, Kenya, in which delegates were equipped to conduct poisoning intervention training. Following on, these trainees have since conducted training workshops themselves, reaching 233 individuals from 35 community environmental groups in Kenya. We are pleased with this excellent response to our train-the-trainer approach, and its ability to reach out to a wider audience in cost-effective way. In addition, in February 2018, the Kenya Wildlife Service (KWS) formally adopted a Response Protocol for Wildlife Poisoning Incidents in Kenya. This protocol will be used to train all relevant KWS staff to implement the organisation's wildlife poisoning prevention strategy. This is a direct outcome of our Maasai Mara workshop, and their approved document is based on the EWT's Wildlife Poisoning Response Protocol. We made good progress in discussions with relevant stakeholders and we plan to expand the focus of our poisoning intervention training in the coming 12 months to include Botswana, Zimbabwe and Tanzania, with an important focus on the development of in-country training capacity.

Wildlife poisoning incidents, unfortunately, continue to happen throughout Africa and these affect a wide range of species beyond vultures. The development of the African Wildlife Poisoning Database by the EWT's Conservation Science Unit, working with our programme, as well as the Peregrine Fund in East Africa, aims to collect and collate information of all known wildlife poisoning incidents on the continent. These data will be invaluable in guiding decisions about which areas we should target with regard to our poisoning intervention training.



Mbashene poisoning incident



Learners undergoing practical poisoning scene investigation training



Two White-backed Vultures with a Lappet-faced Vulture

Sadly, this year has been characterised by a number of large-scale wildlife poisoning incidents across Africa. Vultures continue to be the group of animals most severely affected by the inhumane, and often deliberate, use of a range of chemicals, which kill large numbers of these threatened birds.

- In March 2018, 76 Critically Endangered African White-backed Vultures (*Gyps africanus*) were killed near the Ruaha National Park in Tanzania after feeding on the carcasses of six lions poisoned by villagers in retaliation for the predation of livestock by the pride. This coincided with the killing of 40 vultures in the Maasai Mara region of Kenya in April 2018, when herdsman poisoned a carcass targeted to kill predatory lions, while in southwestern Zambia in December 2017, 168 vultures were killed after feeding on an elephant carcass killed in response to crop damage.
- Since 2011, when the first incident of this nature was detected in southern Africa in association with ivory poaching, more than 3,500 vultures have been poisoned in recorded incidents of this nature in the region (although it is likely that many more of these incidents are never detected or reported). The most recent example of so-called sentinel poisoning was confirmed in southern Mozambique, in February 2018, when 96 African White-backed Vultures and seven Critically Endangered Hooded Vultures (*Necrosyrtes monachus*) were killed at a poisoned elephant carcass in the Mbashene District after a poacher had laced an elephant carcass with the insecticide carbofuran.

African vultures – filling the knowledge gaps

Working in close coordination with our in-country and international partners, we were able to secure research and monitoring permits – focused on filling knowledge gaps with regard to vulture populations and movements in Zambia and Mozambique – two priority countries earmarked for such work by the Vulture MsAP.

Samples of wing-tagged and tracked vultures

Location	No. of tracked birds	Ringed/Wing-tagged	No of species
Gorongosa National Park, Mozambique	19	43	3
Chisamba, Zambia	3	4	2
Total	22	47	3

We assisted our Birds of Prey Programme to expand its sample of wing-tagged and tracked vultures in the Lowveld, fitting 21 vultures of three different species with rings and wing-tags, while five of these birds were also fitted with tracking devices. This included 11 vulture nestlings we tagged at the Hoedspruit Air Force Base and Timbavati Private Nature Reserve.



Mozambican students with a juvenile Bateleur



Poison kit training

Communication and awareness

We celebrated International Vulture Awareness Day (IVAD) for the ninth time since its inception in 2009, on 2 September 2017. This year, 32 countries and 138 organisations registered their activities on the IVAD website.

The EWT was selected to co-host the Raptor Research Foundation Annual Conference at Skukuza, in the Kruger National Park, in November 2018, after our conference proposal was approved at the 2017 Annual Conference in Salt Lake City, Utah, USA. This will be the first major international raptor conference held in southern Africa since 1996, and we expect 150–200 delegates to attend this event, which we will co-host with BirdLife South Africa.

Programme manager, André Botha, delivered 30 presentations to 2,043 people through the year. This included a plenary presentation at the Raptor Research Foundation Conference in Salt Lake City, in November 2017, as well as a presentation to the staff of the US Fish and Wildlife Service (USFWS) at their head office in Virginia, USA, in May 2018. The latter was broadcast via live internet link to all USFWS staff offices across the USA. Our work was featured in 239 printed and electronic media articles, as well as providing 14 interviews on national radio, and appearing in a single television interview. The programme manager was involved as author or co-author of 11 scientific peer-reviewed publications and presentations during the review period.

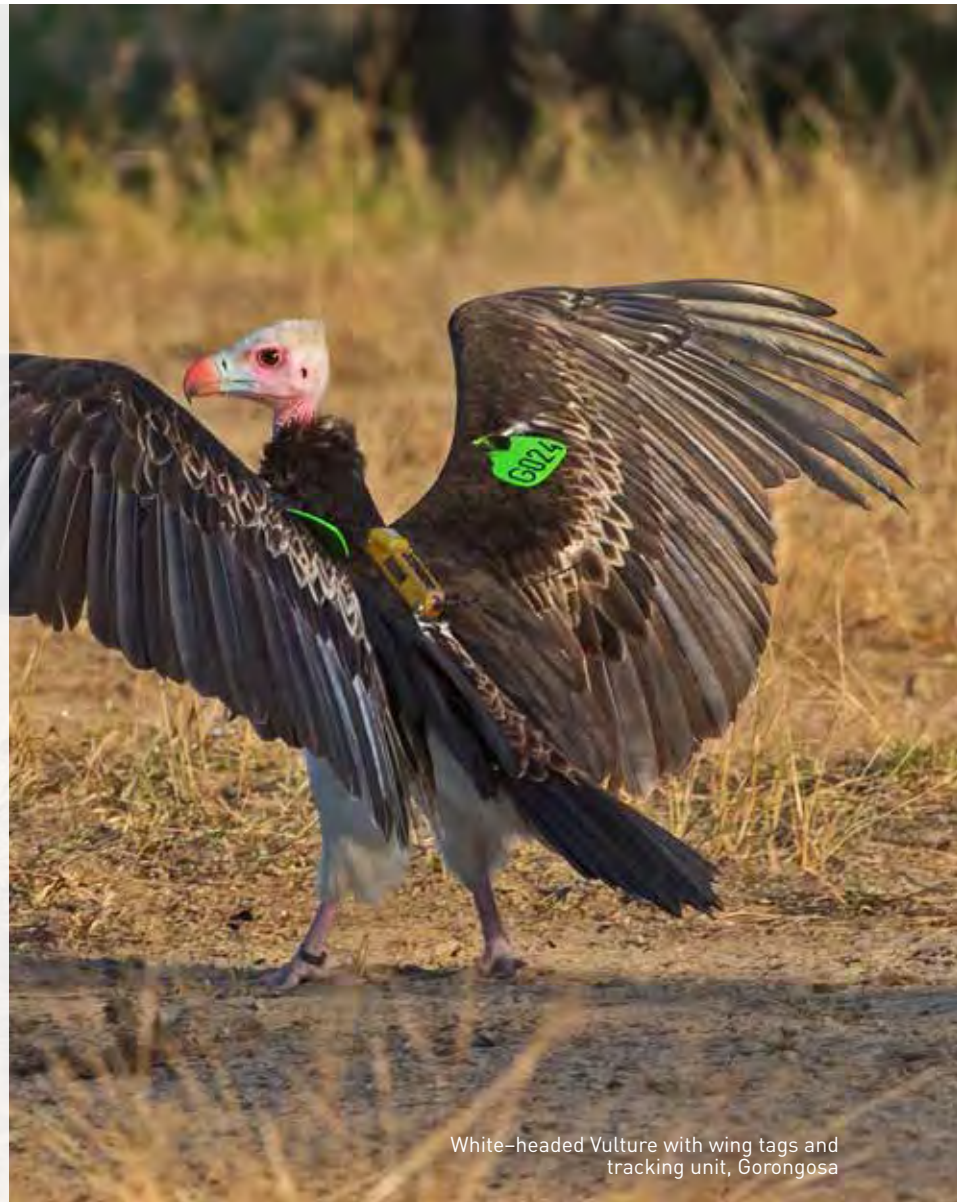

White-headed Vulture with wing tags and tracking unit, Gorongosa



Juvenile Cape Vulture

What our stakeholders are saying

“With support from the EWT we began our Stop Poisoning Now campaign in March 2017 and to date we have trained 233 individuals representing 35 different community environmental groups, conservancies, national reserves, conservation NGOs, policemen, and government institutions.” – Dr Darcy Ogada in a report on Poison Intervention Training activities and its impact in Kenya: Dr Matt Becker – from the Zambia Carnivore Project Annual Report

“Such a mammoth task would need experienced, engaging conservation leaders that had at the same time deep technical knowledge of the situation, be great communicators, and have good project management skills. We were therefore very happy to team up with André, who has led a team of people in which we were included in an admirable way.” – Dr José Tavares – Director, Vulture Conservation Foundation, a partner in the drafting of the CMS Vulture MsAP in a letter of support for the programme manager, André Botha.



Andre releases a Hooded Vulture after tagging

VULTURES FOR AFRICA TEAM



André Botha
Programme Manager



Rebecca Mabuza
Administrator

Sustainable Development Goals



Aichi Biodiversity Targets



A legend for these icons can be found on pages 9–10.



To watch us conduct an aerial survey of vultures in Gorongosa National Park, and more, visit www.youtube.com/user/EWTSouthAfrica

WILDLIFE & ENERGY

PROGRAMME

Powering change through conservation innovation

Energy infrastructure can have devastating effects on wildlife. The EWT's Wildlife and Energy Programme (WEP) aims to have a positive influence on the wildlife management policies of utilities, thereby reducing their impact on wildlife, improving quality of supply to customers, and ultimately phasing out problematic processes and hardware to substantially minimise wildlife interactions with electricity infrastructure in Africa.

Since its inception in 1996, the EWT's WEP has been implementing innovative measures to assist Eskom on a number of biodiversity-related issues. This year we expanded the scope of our efforts as well as our staff complement to ensure that our programme remains effective through innovative thinking and the application of new technology wherever appropriate. These innovative tools will reduce costs, streamline processes and enable us to conduct work previously thought impossible.





New tech: from concept to conservation

Birds regularly collide with overhead power line cables – which they often do not see– killing many in the process. We have shown that installing bird flight diverters to the earth wires of transmission lines can work to reduce collisions. These devices are installed to live lines by a highly-trained live-line team using a helicopter. This presents obvious logistical and financial challenges and can pose a major risk to human safety. We have therefore been working on a solution that will reduce these risks, while improving line-marking efficiency, through the use of unmanned vehicles, particularly remotely piloted aircraft systems, or 'RPAS'.

The industrial use of RPAS, known colloquially as drones, is growing at an unprecedented rate. Their application in the South African conservation sector remains novel, but this too is changing. In order to address the line-marking problem, WEP and Eskom Research, Testing and Development have been working on a system to attach bird flight diverters to power line cables without the use of a helicopter.

During the past year, we conceptualised a line-marking device that can be hoisted up to a power line using a drone. Using 3D modelling and printing, the device's different components are mostly custom-designed and manufactured to fit to the drone. Using PLA (polylactic acid), which is derived from renewable resources such as corn starch and sugar cane, they are environmentally friendly too. We have been continuously improving the device, making it more robust and lightweight as a payload. Real-world tests of the device are still pending due to the legal and administrative processes instituted by the South African Civil Aviation Authority. Once we have the necessary clearances to fly, we will present a proof of concept to Eskom.

3D modelling

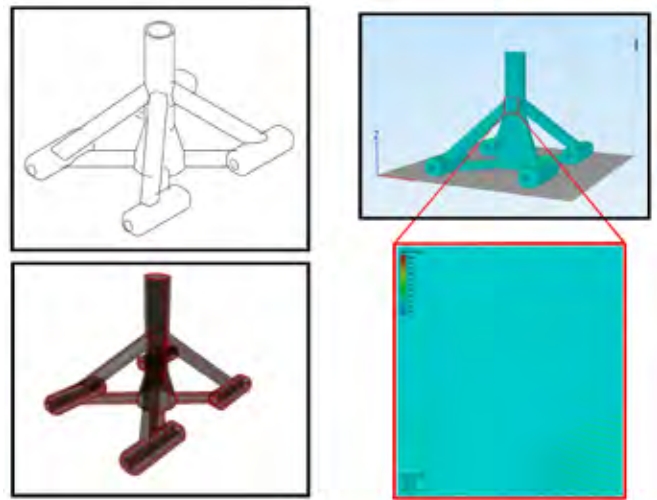

RPAS line-marking device



Blue Cranes in flight. Photo credit Wicus Leeuwner



Black Eagle nesting on a transmission structure in the Karoo

Flamingo returns from two-year stay in Madagascar

During 2016, we fitted satellite-tracking devices to 12 Lesser Flamingos in order to examine the flight behaviour of these threatened birds. The results were surprising, indicating long-distance nocturnal movements that had previously been unrecorded. On 9 June 2016, the EWT recorded the first cross-border movement of an individual Lesser Flamingo (*Phoeniconaias minor*) to Madagascar. Kucki, named by Eskom's Environmental Manager, Deidre Herbst, after Kucki Low, the first South African woman to obtain her commercial pilots license and South Africa's first female flight instructor in 1970, flew 1,020 km in a single flight in just under 24 hours.

Since then, Kucki remained in Madagascar where she moved up and down the coast, and even survived the onslaught of cyclone Dineo, which hit the coastline in 2017. Then, on 29 May 2018, Kucki finally made her return to mainland Africa, flying 927 km over the Mozambican Channel from Madagascar to Mozambique, and landing south of Beira. Curiously, her arrival to and departure from Madagascar occurred at the exact same point in the mouth of the Mangoky River. This remarkable journey has raised new questions about why flamingos undertake these movements and what environmental triggers contribute to them.

Lesser Flamingos



Research, research, research

To mitigate bird collisions in the Karoo we attached two types of line markers (bird flight diverters and bird flappers) to power lines to improve their visibility. We then monitored bird collision mortalities over a period of eight years (2008–2016) on a 109-km stretch of 400 kV transmission lines near the Hydra substation.

This year we completed the final analysis of our investigation and submitted the findings to Eskom Research and Development. Encouragingly, we found that marking the lines decreased mortalities for Blue Cranes (*Anthopoides paradiseus*) and other large birds, while the two types of marking devices performed similarly. For some species, such as the Endangered Ludwig's Bustard (*Neotis ludwigii*), the markers did not help to reduce mortalities. To address bustard power line collisions, we plan to investigate new mitigation solutions that cater for the visual acuity, flight speed, reaction time and the binocular overlap of bustards.



Ludwig's Bustard



Ludwig's Bustard

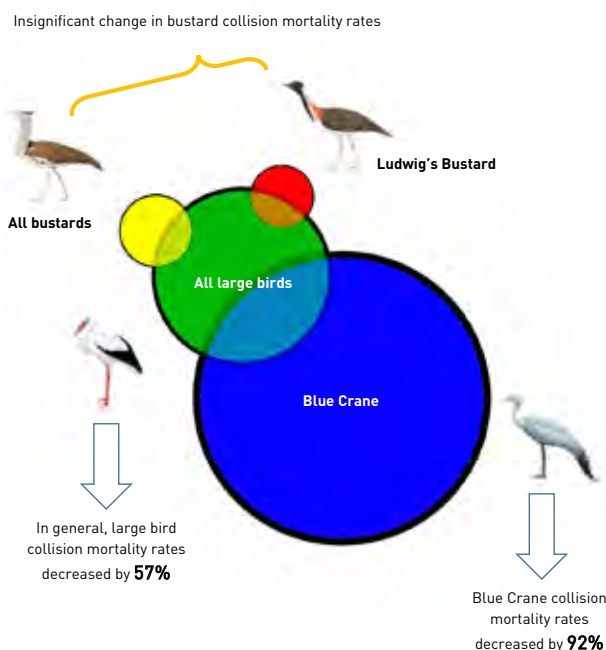

The effectiveness of line markers in reducing large bird collisions

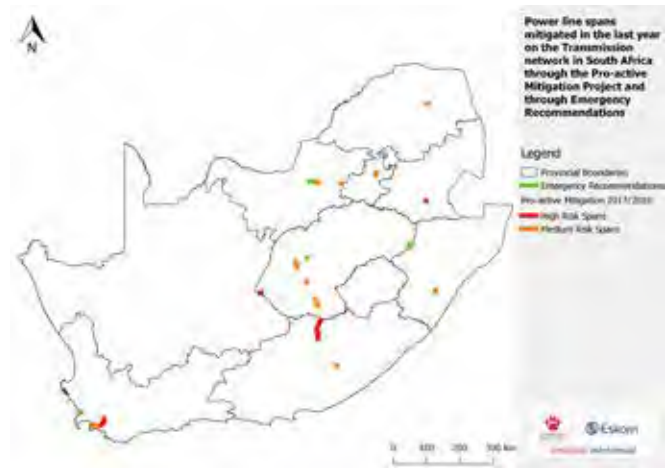

Priority maps for proactive mitigation



Eskom and the EWT's proactive campaign

The EWT embarked on an exciting project towards the end of 2016 to proactively identify transmission lines (lines above 132 kV) across South Africa that had a high risk of bird collisions. This detailed modelling and mapping exercise aims to reduce the number of threatened bird collisions through a systematic pro-active mitigation strategy. Each year, we send each Eskom transmission grid (ten across the country) a detailed mitigation plan detailing which high and medium risk spans require marking with bird flight diverters in their upcoming maintenance plan cycle.

Bird flight diverters make the line more visible to birds in flight, and reduce the risk of collision. These devices are extremely effective, especially for crane species. Through this innovative and one-of-a-kind mitigation strategy, some 334 power line spans (approximately 149 km) have been proactively mitigated during the last financial year throughout South Africa. In addition to this, 68 spans (~30 km) of power line were mitigated reactively after the EWT sent recommendations to mitigate spans on additional lines after bird collisions occurred. The EWT tracks these measures and maps them on a monthly basis, while Eskom receives a monthly score from the EWT that reflects the mitigation (both reactive and proactive) completed by the relevant Eskom grid.

Not just the birds

In the last year, the Eskom EWT Strategic Partnership broadened its focus to assist Eskom with all aspects of biodiversity. Eskom's numerous generation sites usually have large footprints and some even have declared nature reserves as part of the property. They include Ingula Pumped Storage Scheme, on the border of KwaZulu-Natal and the Free State, and Majuba Power Station in Mpumalanga. These nature reserves harbour highly threatened species such as the White-winged Flufftail (*Sarothrura ayresii*) and the Sungazer (*Smaug giganteus*).

The EWT has now generated game management plans for 12 of Eskom's coal-fired generation sites. These plans will assist Eskom staff in the management of their wildlife and infrastructure, dealing with human wildlife conflict, and managing fire, as well as ensuring the long-term protection of threatened species on the properties. In February 2018, we began assessing selected Eskom properties for suitability as safe release sites where threatened species, confiscated at airports and ports, can be re-established



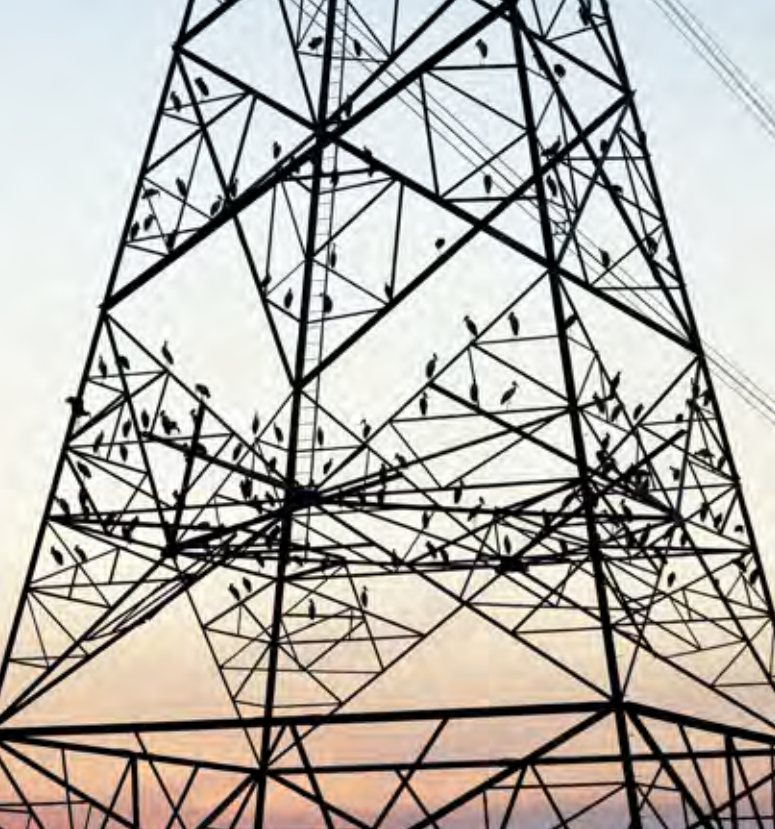

WEP training project spreads wings to Lesotho

Our training project, historically focusing on Wildlife and Power Line Interaction Training within the Eskom business, has conducted training in Lesotho for the first time. This training raises conservation knowledge that is essential to Eskom's everyday tasks, and the various possible interactions between electrical infrastructure and wildlife. It also increases reporting rates of wildlife and power line incidents, which enables us to understand these interactions better, highlight sensitive areas, and predict where collisions may take place in future. For these reasons, the Lesotho Energy Corporation (LEC) has been eager to roll out training to their staff, as both the Bearded Vulture (*Gypaetus barbatus*) and the Cape Vulture (*Gyps coprotheres*) range extensively through the Lesotho Highlands, with a high risk of interacting with electrical infrastructure.

Over the last year, the EWT undertook three training sessions in Lesotho to capacitate personnel to deal with wildlife interactions on their infrastructure. The LEC is now planning proactive mitigation measures on infrastructure in Lesotho – to reduce both collisions with power lines and electrocutions – to help conserve wildlife. More LEC personnel will now execute their duties with wildlife and power line interactions in mind, thereby helping to minimise the impacts of the LEC's activities on birds and other wildlife.

Biodiversity impact study at Sere Wind farm enters fourth year

The Sere Wind Farm is located on South Africa's West Coast, near the town of Lutzville. Here, the EWT has been monitoring wind turbine related wildlife mortalities for the last three years. As we enter the fourth year of monitoring at Sere, our data show a distinct decrease in turbine related mortalities. The confirmed direct impact of turbines on bats (0.4 bats/turbine/year) and birds (0.2 birds/turbine/year) is within the industry norm of 3–5 bats/turbine/year and 1.41 birds/turbine year. There is no apparent disturbance or displacement of birds and bats caused by the Sere Wind Energy Facility. Species abundance varied seasonally but overall presence was similar to the pre-construction survey. We are also building a species list for the property, with the help of camera traps. The photographs will be displayed at the Sere visitor's centre and for educational purposes at local schools. Bat-eared Foxes (*Otocyon megalotis*) are common on site. Unfortunately, they are often recorded as fatalities by our roadkill project, which has been active at Sere since 2015, constituting 80% of all mortalities. Although the focus is often on finding carcasses, other live wildlife recorded on the property included Endangered species such as Ludwig's Bustards and Black Harriers (*Circus maurus*).



ESKOM AND THE EWT ARE #POWERINGCHANGE

ENDANGERED WILDLIFE TRUST

Eskom

STRATEGIC PARTNERSHIP

Even the smallest action can create a surge of change. By choosing to get your daily fix in this reusable bamboo coffee mug, you're already making a significant contribution to reducing the amount of plastic polluting our environment. Be a #PoweringChange Champion, and let others know how they can join the campaign to lessen our impact on the Earth through the small steps we can all take.

Snap a photo of yourself with your **#PoweringChange** reusable mug, share this on Instagram, tagging **@ewt** and **@eskom**, and let everyone know why you're taking action and **#PoweringChange**

Eskom and the EWT are powering change to reduce plastic use

The term single-use plastics has gained global notoriety this year. Designed to be durable, versatile and waterproof, it is these traits that prevent them from degrading in the environment. This is why the EWT and Eskom have joined forces to encourage small shifts in daily behaviour. We have focused on the use of polystyrene cups at Eskom Generation sites, and have presented staff with alternatives such as bringing their own coffee mugs to work.



What our stakeholders are saying

“Wildlife and energy continue to form an interface that presents both risk and opportunities towards the conservation of habitats and species. The partnership between Eskom and the Endangered Wildlife Trust allows for more strategic implementation to ensure that Eskom’s activities have a reduced impact on wildlife. The work completed by the EWT’s Wildlife and Energy Programme continues to minimise Eskom’s impact on biodiversity and provides consolidated opportunities to further enhance biodiversity.” – Kishaylin Chetty, Eskom Senior Environmental Advisor

“Kudos to your team! I’m working with Lauren McGough (conducting research in South Africa but a Board member of the Falconry Fund) and she’s rehabbing an 11-month-old Martial Eagle she observed shocked on an ESKOM pole. She was duly impressed at both Eskom’s commitment to a rapid response to fix the pole and the EWT’s rapid response to identify how to fix the structure. I believe she used the words ‘fabulous organisation!’ Nice to hear!” – Lori Nielsen, Research Biologist.

“The monitoring of birds’ flight patterns by Eskom’s research department and the EWT are primarily to minimise the number of bird fatalities and ensure quality of supply to Eskom’s customers. In addition, it has resulted in the first ever recorded flight of a Lesser Flamingo across the Mozambican Channel, contributing to a greater understanding of the species. This is an inspirational outcome of our continued research.” – Deidre Herbst, Eskom Environmental Manager.



WILDLIFE & ENERGY PROGRAMME TEAM



Lourens Leeuwner
Programme Manager



Marianne Golding
Administrator



Amos Letsoalo
Senior Field Officer



Matt Pretorius
Senior Field Officer



Samantha Page-Nicholson
Senior Science Officer



Megan Murison
Programme Officer



Ronelle Visagie
Senior Field Officer



Lizet Tolken
Renewable Energy Field Officer



Oscar Mohale
Field & Research Assistant



Dalena de Wee
Renewable Energy Field Officer Intern



Jun-Ann Josephs
Renewable Energy Field Officer Intern



Meitjie van Wyk
Renewable Energy Field Officer Intern



Kgothatso Seeisa
Intern

Sustainable Development Goals



Aichi Biodiversity Targets



A legend for these icons can be found on pages 9-10.



To uncover the amazing journeys of Lesser Flamingos, and more, visit www.youtube.com/user/EWTSouthAfrica

WILDLIFE & TRANSPORT PROGRAMME



Our Roads in Parks Project achieved a

98%

change in driver behaviour in Pilanesberg National Park, significantly reducing collisions with wildlife

Reducing the impact of roads

The EWT's Wildlife and Transport Programme works to reduce the negative impacts of transport infrastructure on wildlife, and ultimately improve driver safety through a reduction in wildlife-vehicle-collisions.

Vehicle collisions kill ~45 people each day in on South African roads, with many of these collisions involving animals. Insurance claims suggest that approximately R82.5 million is paid each year against vehicle collisions with wild animals, though the costs of these collisions to wildlife are never calculated. So what are the consequences for animals? The EWT's Wildlife and Transport Programme is tackling this question and is working to find solutions to the problems associated with wildlife and transport infrastructure.

Wildlife and roads projects

Roads are critical for to economic development, and road construction is set to continue unabated through the foreseeable future. Unfortunately, roads have mostly negative consequences for biodiversity. Amongst other things they destroy and degrade habitats, fragment wildlife populations and their dynamics, increase mortality through collisions, and increase access to previously remote areas thereby increasing natural resource use. The science of road ecology – our understanding of impacts of roads on wildlife – is fairly well developed in North America, Europe and Australia, but is in its infancy in Africa.

Does size matter?

Working with Tshwane University of Technology, we are assessing drivers' attitudes towards snakes, and indeed, whether they are killed deliberately by motorists. Using three different sized fake (rubber) snakes, we determined that most drivers do alter their behaviour to snakes on the road, and in most cases, the bigger the snake, the more likely they are to alter their course to avoid a collision. However, about 20% of drivers deliberately changed their course to drive over the fake snake. Determining why some drivers elect to deliberately kill a snake is the next challenge in our project. Bridging the gap between biological and social sciences is an area in need of attention – we can only start to make a difference through understanding why people behave the way they do.



Highways in Ethiopia

Our programme offers support to other developing countries and our expertise has been sought by researchers, including in Ethiopia where we collaborate with the Ethiopian Biodiversity Institute in undertaking an assessment of roadkill rates for all vertebrates along the Ethio-Djibouti highway. This highway passes through five protected areas in eastern Ethiopia, and is home to several species of conservation significance, such as the Endangered Grevy's Zebra (*Equus grevyi*), and Near Threatened Striped Hyaena (*Hyaena hyaena*).

A total of 128 roadkill incidences were recorded consisting of 44 species from 25 families. Birds were the most frequently killed taxonomic group (56.8%) followed by mammals (38.6%), and reptiles (4.5%). Of the 128 roadkill and according to the IUCN Red List of Threatened Species, 81.8% were of Least Concern, 6.8% were Vulnerable and 5.7% Near Threatened. Diurnal species constituted the majority of roadkill detected (71.3%) with 19.8% being nocturnal and 2.8% being crepuscular. Most roadkill were encountered on roads adjacent to protected areas than roads >60 km from protected areas.



Driving social change

Citizen science represents a collaboration between professional conservationists and the general community in problem solving and data collection. The approach has facilitated analysis of ecological processes operating at broad spatial and temporal scales, far beyond the limit of traditional field studies.

Our Wildlife and Roads Citizen Science Project established the first national database for animal road mortalities and, to date, over 200 citizen scientists have reported almost 20,000 roadkill data points throughout southern Africa. This has allowed us to identify those species and habitats at most risk from roads. Information like this leads to roads being formally recognised as a threat to the survival of many species in the recently published national Red List of Mammals of South Africa, Swaziland and Lesotho. The data have also been used to inform our recent scientific paper that will guide future management decisions on mitigating the negative impacts of roads, and provide a platform from which to design future studies.

Who are our partners?

Working closely with stakeholders in the transport sector is integral to our work. Currently, we support three of South Africa's toll concession companies: Bakwena N1N14 Toll, TRAC N4 and N3 Toll Concession. Together, we address a reduction in wildlife-vehicle collisions, as well as the impact of these collisions on human safety. In 2017, almost 15,000 people were killed on South African roads. We are examining ways to quantify how many of these fatalities resulted from animal collisions, and balance the cost of vehicle damage, injury to, or loss of human life, against the cost of interventions that will significantly reduce collisions with animals. This will ultimately result in a reduction of roadkill, and an improvement of human safety on roads. In 2017/18, we delivered six training courses, supporting 75 staff in road ecology related matters.

Roads in parks

With high visitor numbers, wildlife–vehicle collisions commonly occur in South Africa’s 23 national parks. With tourism expected to grow significantly, there will inevitably be more vehicles in these protected areas, and more collisions. Social media has highlighted public concern for collisions inside protected areas, and we consequently launched our Roads in Parks Project in 2014. Starting in the Pilanesberg National Park, the main goal of our five–year project is to reduce the rates of roadkill in South Africa’s protected areas. This last year we investigated factors affecting the likelihood of collisions in Pilanesberg National Park. Through a series of controlled experiments, using dummy wildlife, we found that an interaction between driver speed and driver occupation (staff or visitors) was the best predictor for wildlife–vehicle collisions. Contrary to our predictions, when driving below the speed limit, visitors were almost three times more likely than staff to hit our dummy snake. Collision probabilities increased when speeding, becoming more similar between visitors and staff, although still significantly higher for visitors.

We also investigated the effectiveness of signage in modifying driver, using signs depicting either a Cheetah (*Acinonyx jubatus*) or a snake. Significantly, using signage improved wildlife safety, as 61% of drivers who passed a wildlife–warning sign changed their behaviour when they saw a dummy snake placed on the road, compared to 37% with no sign present. This reduced collisions with the snake, with 98% of drivers positively altering their behaviour. The distance from the sign to wildlife on the road played a role too, as a wildlife–warning sign depicting a snake, and placed 100 m (as opposed to 1,000 m) before the dummy snake, was most effective at reducing collisions. Our results suggest that drivers adapt their behaviour to signage that portrays smaller animals and that awareness retention is low. We have subsequently extended our research into the Kruger National Park, where it forms part of a B.Tech. degree (Tshwane University of Technology) and a Master’s degree (University of Venda). The outcomes of our research will assist SANParks with a traffic–monitoring plan, and ultimately reduce roadkill in our protected areas.

Carrying out roadkill surveys by driving a road over long distances is both costly and time consuming. To address this, our joint project with the University of Venda and GreenMatter aims to design a more cost–effective method of undertaking surveys. We will generate a roadkill risk model to determine which environmental and road–related factors contribute to roadkill. We will test this model in the Kruger National Park and we will hopefully be able to use it as a blueprint for other protected areas in the country.



Making a difference on roads in South Africa: tools that drive mitigation

We collaborate with a number of research institutions to support and facilitate projects that implement and assess the effectiveness of roadkill–mitigation–measures. Working together, this will ultimately lead to a reduction in animal road–mortalities. These include the Samango Monkey Roadkill Mitigation Project. This project addresses the high numbers of Samango Monkey (*Cercopithecus mitis*) road deaths along a particular stretch of road along the eastern Soutpansberg Mountains. This project aims to design and install permanent canopy bridges specifically suited for Samango Monkeys – a rare primate that inhabits highly fragmented high canopy forest habitat. Having completed a camera trap survey, and with two years of behavioural data about how Samango Monkeys cross their canopy–bridges, we are preparing guidelines for a “primate canopy overpass,” for conservation and management use. We continued with our awareness work in the Soutpansberg to make motorists aware of this threatened species.

Working in close partnership with the N3TC toll company, data collected by their patrollers has enabled us to identify species most at risk from roads. This has highlighted the plight of Servals (*Felis serval*), a small cat species. To date we have data from 94 Serval mortalities on the N3 Toll Route from 2014 to 2017, stretching the length of this highway. In conjunction with the EWT’s Carnivore Conservation Programme and the University of Venda, we have used the invaluable data collected by patrollers to determine the environmental and anthropogenic variables most related to Serval deaths, which was greater in areas with lower rainfall. This information provides an opportunity to determine where N3TC should target their mitigation efforts for Serval along the highway.

Travelling in new directions: impacts of linear infrastructure on wildlife

To date, our projects have focused primarily on the impacts of roads on wildlife. This new project will expand our outreach more widely across the transport sector (railways, marine shipping) and linear infrastructure (fencing).

In 2018, we expanded our road ecology training to incorporate rail ecology, the first training of its kind in the country. We delivered a three–day Road and Rail Ecology Training Course to field rangers and management of the EWT’s Medike Nature Reserve in the Soutpansberg Mountains. These mountains – part of the Vhembe Biosphere Reserve – are bisected by a railway, and with plans to upgrade the railway line and the surrounding substations, we are now gathering baseline data of rail mortalities here.

Marine wildlife is also impacted by collisions with shipping vessels. We have commissioned a study into the scope and extent of collisions between marine vessels (cargo ships, cruise liners, and recreational vehicles) and marine species, such as whales, sharks, dolphins, marine turtles, penguins and seals. We currently operate within South Africa, but our network is continent–wide. As the leading experts in this field, we work towards expanding our support and training to other African countries. In order to accelerate learning in the field of road ecology in Africa, and in conjunction with the EWT’s Wildlife and Energy Programme, we are facilitating an international conference for linear infrastructure (the African Conference for Linear Infrastructure and Ecology) to foster international collaboration and sharing of good practise, which will take place in March 2019.

What our stakeholders are saying

“The EWT is lucky to have champions like you who are committed to making a difference.” – Patience Gandiwa, International Conventions & Transfrontier Conservation Areas Department, Zimbabwe Parks and Wildlife Management Authority Headquarters.

“You have been working so hard and putting in lots of sincere efforts to help protect and conserve wildlife. It is indeed a proud moment for all of us who are directly or indirectly associated with you, to win a Science Oscar.” – Satish Kumar, Department of Wildlife Sciences, Aligarh Muslim University, India

We held two Roadkill Awareness Days in Pilanesberg National Park, where we engaged with visitors to the park and provided updates of the research being undertaken. We have given over 20 presentations to relevant stakeholders in the transport sector (e.g. South African Insurance Association, Road Safety Summit), public forums (e.g. Greater Mapungubwe Network, Vhembe Biosphere Reserve) and various events (e.g. SA Jagsters, Country Club Johannesburg).

We are currently mentoring four students on road ecology projects (two B.Tech. and two M.Sc.) and providing input into one Ph.D. – thus providing opportunities to expand their knowledge.

In 2017/18, six training courses were delivered to three toll concessionaire companies (Bakwena N1N14 Toll, TRAC N4 and N3 Toll Concession), supporting 75 staff.

Recognition

We are extremely proud to be the recipient of the TW Kambule–NSTF Award: Emerging Researcher at the National Science and Technology (NSTF) awards. Wendy Collinson scooped the prestigious award for her work in establishing and running the EWT’s Wildlife and Roads Project.

In 2017, we joined the IUCN’s Transport Working Group and Connectivity Conservation Specialist Group. We were invited to serve as committee members on the international Transportation Research Board (TRB) and the International Conference for Ecology and Transportation (ICOET). This enables us to partake in global discussions for the direction of road ecology.

We strive to undertake high-quality scientific studies and frequently publish scientific papers in international peer-reviewed journals. Through our partnerships with academic institutions, we ensure that our scientific understanding is innovative and contributes towards finding solutions to some of the challenges we face in conservation. In the last year, we published two scientific papers in peer-reviewed journals, with a further two under-review and five in preparation. We attended a number of national and international conferences representing the work undertaken by the EWT.

WILDLIFE & TRANSPORT PROGRAMME TEAM



Wendy Collinson-Jonker
Programme Manager



Innocent Buthelezi
Field Officer



Brilliant Mashao
Field Officer

Sustainable Development Goals



Aichi Biodiversity Targets



A legend for these icons can be found on pages 9–10.



To find out how we reduce wildlife and vehicle collisions in national parks, and more, visit www.youtube.com/user/EWTSouthAfrica

WILDLIFE IN TRADE

PROGRAMME



Reptiles are commonly victims of the illegal pet trade



Tackling illegal trade

The purpose of the Wildlife in Trade Programme (WITP) is to reduce trade-related threats that negatively impact the survival of wild animals and plants. We continuously explore innovative approaches and opportunities to achieve our purpose. We focus our initiatives across five thematic areas: prevention, detection, justice, governance and use.

The programme's primary focus is to save species and we do this through targeted interventions that lead to measurable reductions in the trade-related threats to species of concern. Our interventions build capacity to prevent wildlife crimes and to detect them when they do occur; they seek to ensure justice for wildlife crimes and that good governance for wildlife is achieved; and we actively work to ensure that legal trade is conducted responsibly and is ecologically sustainable.



Patrol optimisation

Observations made by rangers out on patrol, when properly analysed, provide valuable information about poaching trends, thus ensuring future patrols are deployed efficiently to areas under the greatest poaching threat. To ensure this information is properly analysed, we initiated a data collection and patrol optimisation project, which provided training highlighting what kind of information can and should be recorded by rangers (for example footprints, breaks in the fence line and evidence that people were sleeping in an area). With these observations properly recorded on a programme called CMore, developed by the Council for Scientific and Industrial Research (CSIR), the observation data could be analysed. When the observation data was analysed it allowed for more informed decision making as to where patrols should be deployed.

Over the course of the last year, we implemented anti-poaching data collection programmes in six important rhino reserves and conducted four wildlife crime analysis training interventions, training 28 analysts. Participants will now be able to analyse information collected by rangers and ensure that patrols are deployed in a way that will best protect rhinos.

This work was supported by funding received from the US Bureau of International Narcotics and Law Enforcement Affairs and MyPlanet Rhino Fund.



Oros



Kelly and Fly



Vito



Spike

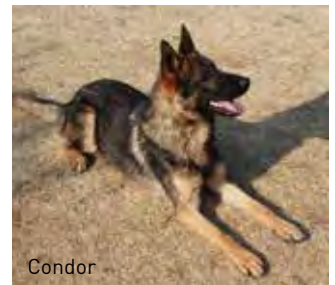

Condor

Conservation Canines

Conservation Canines are trained domestic working dogs that offer support to anti-poaching units and play a vital role in the protection of South Africa's wildlife. The WITP provides trained Conservation Canines to handlers on reserves across South Africa. The dogs remain the property of the EWT and we provide ongoing training support for the dogs and their handlers, as well as medical aid for the Conservation Canines. We provide three different types of Conservation Canines:

1. Tracking Conservation Canines that can follow human scent to allow the anti-poaching unit to follow poachers through the bush;
2. Detection Conservation Canines that have been trained to sniff out and indicate the presence of various items; our Conservation Canines mainly detect rhino horn, ivory, pangolin and ammunition.
3. Patrol Conservation Canines, who will support the Black Mambas, an all-female, unarmed anti-poaching unit based at Balule Private Game Reserve near Hoedspruit. These women walk patrols of up to 20 km per day, unarmed in big five country. The Patrol Conservation Canines will walk with them, providing an added layer of visible policing, and act as a first warning system for dangerous game in the area.

We currently have ten Conservation Canines actively working in the field with dedicated handlers, three in maintenance training, and three in tracker training. The last six will be deployed shortly. This year we carried out formal refresher training with all of our field-based dogs. We can report that all the Conservation Canines and their handlers performed very well, and we are confident that they are working effectively.

In one of the reserves to which we deployed a Conservation Canine, no rhinos were poached in more than 372 days, while their neighbours had all lost rhinos. Another reserve was losing more than ten rhinos a year before the deployment of a Conservation Canine. Tellingly, within three months of deployment, a major arrest was made, and the reserve has now gone nine months without poaching in our Conservation Canine's region of operation. The same Conservation Canine was directly involved in cases leading to nine arrests in 2018.

In June 2018, one of our Detection Conservation Canines on a reserve in the lowveld searched 64 staff housing rooms, 72 service provider vehicles at the reserve gate, and 47 staff private vehicles. In the same month two Detection Conservation Canines on a reserve on the Western Boundary of Kruger searched an average of 357 vehicles (tourists, staff and service providers) between them at three different gates. These two Conservation Canines found 100% of declared firearms and also searched four lodges in the same month.

A key challenge we face in implementing effective Conservation Canine support projects is a lack of suitably qualified handlers, either to handle dogs, or to assist with the ongoing training requirements of the dogs and handlers. We began addressing this by training two learner handlers – Shayen Seebran and Qolile Mathebula – to get their formally-recognised dog handling qualifications. Their training covered a wide range of course material, from basic kennel management and husbandry, to tracking and detection of various wildlife products like ammunition, ivory and rhino horn. Both learners excelled in their training and will be an asset to the conservation canine sector. Qolile is going to head up the canine unit of the Black Mambas.

The Conservation Canine Project is supported by funding received from US Fish and Wildlife Service, RoyalCanin, the Hans Hoheisen Charitable Trust, MyPlanet Rhino Fund, and funding from several generous individuals, corporations, foundations and trusts.



Annie



Saving rhinos

In addition to the two projects discussed above, the WITP has undertaken several other initiatives to reduce rhino poaching. One such initiative was the hosting of an Advanced Grade Five EMI Training Course. This course aims to provide the skills and knowledge required by first responders to a wildlife crime scene, including rhino crime scenes. The course consisted of four modules, presented both theoretically and practically. The modules were: arrests; search, seizure and pointing out; collection of evidence; and court testimony. We hosted 15 training courses over the last year, and trained 300 participants from the Kruger National Park and protected areas in the Northern Cape. This was part of larger project that commenced in September 2016, under which we hosted 78 training courses and trained 1,273 participants from eight of the nine provinces in South Africa (there are no national or provincial reserves in Gauteng with Grade 5 Environmental Management Inspectors). We recorded an overall increase an overall increase of 26% in knowledge over the duration of the course.

We have also been hard at work developing new and exciting initiatives to contribute to saving rhinos, these projects are:

Rhino horn trade analysis

Continuous analysis of trade trends of rhino horn is vital to ensure compliance with the legal framework. Through improved monitoring of legal domestic trade, illegal trade (both domestic and international) and historic trade in rhino horn, we will be able to ensure that key threats to rhino from trade – both current and emerging – are fully unpacked and reported, thereby facilitating informed decision making and proper accountability.

Dedicated community engagement projects

Communities living near protected areas have had little opportunity to participate in decision-making processes around rhino management and considering the socio-political and historical context as well as continued marginalisation of these communities, their attitude towards conservation is negatively impacted. The WITP has and will continue to undertake initiatives to bring enhanced community involvement within this sector. One such initiative that will contribute to enhanced community engagement is the Restorative Justice Project currently being undertaken by the WITP. This project has been included in the Rhino Action Plan developed by the Department of Environmental Affairs and over the last six months, the WITP has drafted a report on the applicability of restorative justice for rhino and other wildlife crimes. The next phase of the project will commence later this year.

We have also been active in policy reports, participating in the Non-Detriment Finding Report for Black and White Rhino as well as the Rhino Research Strategy-Report.

Our rhino work is supported by funding received from US Fish and Wildlife Service, US Bureau of International Narcotics and Law Enforcement Affairs, the Global Environmental Facility Project (facilitated by the Department of Environmental Affairs), US Agency for International Development (facilitated by WWF – SA), RoyalCanin, the Hans Hoheisen Charitable Trust, MyPlanet Rhino Fund, and funding from several generous individuals, corporations, foundations and trusts.



Detection rats

Shipping ports represent a challenging environment for law enforcement officers because of the volume of cargo that moves through ports on a daily basis. For example, the Dar Es Salaam port in Tanzania handles over 12,500,000 tons of cargo per year. Searching this volume of cargo is logistically difficult and time consuming. Rising to this challenge, we created a novel project using rats, an animal that has been associated with ports and ships for hundreds of years.

Working with our partner APOPO (an acronym for Anti-Personsmijnen Ontmijnende Product Ontwikkeling, or Anti-Personnel Landmines Removal Product Development), we are investigating the viability of training African Giant Pouched Rats (*Cricetomys gambianus*) to detect wildlife contraband in shipping ports. To date, we have successfully trained the rats to detect pangolins and rosewood *Dalbergia* sp. – two



species rampant in the illegal trade market. All 11 rats have successfully completed the early stages of their training and at the advanced training phase; rats are identifying pangolin and rosewood samples at 80% accuracy on average, with very few indications on non-targets (false alarms). Ultimately, we will train the rats to detect these targets within a mixture of non-target samples (e.g. pangolin scales hidden in a cargo of coffee beans). This will allow us to determine how much pangolin or rosewood needs to be present in a shipping container for the rats to detect it. Our knowledge from these laboratory experiments will allow us to explore how best to deploy the rats in order to combat trafficking in real-life settings.

The Detection Rat Project is supported by funding received from US Fish and Wildlife Service and the UK Illegal Wildlife Trade Challenge Fund.

Specialised law enforcement training

Flagship Species Identification Training Course

We designed this course to introduce officials from law enforcement agencies to the scale of trade taking place both globally and in South Africa, highlighting the seriousness of wildlife crimes. We introduced the participants to a wide range of topics and species including birds, trees, mammals, reptiles and marine species. This course included both theoretical and practical components. Over the last year, we trained 40 officials from the South African Revenue Service, thereby building capacity to detect and stop the smuggling of wildlife out of South Africa.

Advanced Cycad Law Enforcement Training Course

Over the last year, we hosted an Advanced Cycad Law Enforcement Course to provide specialised skills to law enforcement officials relevant to the protection and identification of Endangered *Encephalartos* cycad species. With a 90% pass rate on the course, we now have an additional ten law enforcement officials with specialised cycad law enforcement skills, who are ready and able to tackle cycad poaching in South Africa.

Wildlife Trade Law Compliance and Enforcement Training Programme, An Introduction to Wildlife Cybercrime

We hosted the third and final Cybercrime training course with participants from the South African Police Service and Provincial Nature Conservation in attendance. The goal was to improve the awareness of the scope of illegal wildlife trade and to build confidence in addressing this emerging aspect of illegal wildlife trade. We also made a presentation to the Auditor Generals of English speaking African Countries in May 2018 in Rwanda, highlighting the extent of online trade and the seriousness of illegal wildlife trade.

These training initiatives were supported by funding received from the US Bureau of International Narcotics and Law Enforcement Affairs, the Global Environmental Facility Project

Enforcement Affairs, the Global Environmental Facility Project (facilitated by the Department of Environmental Affairs), US Fish and Wildlife Service and International Fund for Animal Welfare.

Engagement with wildlife crime prosecutors

Wildlife Crime Handbook – a Species Support Tool for Investigating Officers and State Prosecutors

We developed the *Wildlife Crime Handbook – a Species Support Tool* for Investigating Officers and State Prosecutors, providing valuable information on the legal framework applicable to the prosecution of wildlife crimes in South Africa. Over 3,000 copies of this handbook have been printed and will be distributed across South Africa.

2018 Regional Prosecutor Workshop

We hosted a southern African regional prosecutor workshop in March 2018. The overall aim of our workshop was to achieve a mutual understanding between the jurisdictions represented at this workshop on strategies to strengthen prosecutions and sentencing of wildlife crimes, and enhance international collaboration. Participants who attended the workshop included senior wildlife prosecutors from South Africa, Mozambique, Botswana, Namibia and Swaziland. It is invaluable for prosecutors to meet and share best practice in addressing wildlife crimes. Our workshop certainly facilitated that, and introduced the prosecutors to key initiatives such as victim impact statements that they can implement in the prosecution of wildlife crimes.

These initiatives were supported by funding received from the US Bureau of International Narcotics and Law Enforcement Affairs, the British High Commission, the UK Department for Environment, Food and Rural Affairs, International Fund for Animal Welfare, African Wildlife Foundation and the Conservation Action Trust.





Pangolin project

We completed the first phase of our pangolin protection project through research into the illegal domestic consumer market. With guidance from Dr Viv Williams at Wits University, two student interns (Thibedi Moshoeu and Nolwazi Mbongwa) conducted observational surveys for pangolins and pangolin products in muthi markets in five provinces (Gauteng, Limpopo, KZN, Limpopo and Mpumalanga) and Swaziland. Thibedi and Nolwazi have gathered an impressive amount of novel research material and we anticipate publishing the results over the next year. This work should go a long way to help guide conservation projects to protect our pangolins and we will be developing the research further to better understand the demand for pangolins in southern Africa.

This work was supported by funding received from Pangolin Photo Safaris.



What our stakeholders are saying

"The training I have gone through, and still am going through, has been conducted by the best of the best dog handlers and trainers, and I am extremely grateful and appreciative of the EWT for giving me this once in a lifetime opportunity to help me follow my passion in this canine anti-poaching effort." – Shayen Seebran, Learner Handler.

WILDLIFE IN TRADE PROGRAMME TEAM



Adam Pires
Programme Manager
(until 31 March 2018)



Ashleigh Dore
Programme Manager
(from 1 April 2018)



Dr Andrew Taylor
Senior Wildlife Trade Officer



Dr Kelly Marnewick
Senior Wildlife Trade Officer



Ndzalama Chauke
Wildlife Trade Officer



Ndifelani Mulaudzi
Wildlife Trade Officer



Shayen Seebran
Canine Handler Learner



Qolile Mathebula
Canine Handler Learner

Sustainable Development Goals



Aichi Biodiversity Targets



A legend for these icons can be found on pages 9–10.



To see our Conservation Canines in action, and more, visit www.youtube.com/user/EWTSouthAfrica

LOOKING FORWARD

WHAT'S NEXT?

Human population and development

As we look to the future, we cannot ignore the growing impact of human population and development on the environment. There are now more than 7.5 billion people on the planet. The United Nations estimates that this number will reach nearly 9.8 billion by 2050 – 30% more than today. Africa's population is set to double over the same period, increasing at one-and-a-half times the global average.

The EWT believes that intergovernmental agencies, governments, and non-governmental organisations, must work together more effectively and holistically to address the key drivers of population growth. These include poverty, limited access to sexual and reproductive health education and services, and the disregard for women's rights. Simultaneously, we need firm action to reduce resource consumption, while supporting communities to become more resilient to climatic, social and economic changes.

The EWT was the first conservation NGO in South Africa to recognise the importance of Population, Health and Environment (PHE) programmes. PHE is a means of acknowledging women's reproductive and health rights, and the role of empowering women to determine their ideal family size. These programmes provide an important model for marginalised rural areas where community health and wellbeing depend on ecosystem health. Integrated PHE programmes result in greater health, human welfare and conservation outcomes than single sector approaches. The EWT is actively integrating PHE into our on-the-ground conservation work, throughout our portfolio. We are also raising awareness through position statements and international advocacy, leveraging on our partnership with the Population Sustainability Network.

The EWT moves into land acquisition

The EWT has historically stayed away from direct land ownership, opting instead to support existing landowners to engage in conservation of biodiversity and natural water resource management. This has however changed in recent years with the EWT recognising the value of being a landowner of critical pieces of land, in order to secure their long term conservation and natural value. The Soutpansberg Protected Area Project was catalysed by the purchase of the Medike Nature Reserve in November 2017, through the generous support of the Roberts' Family in Australia. Working in partnership with the Rainforest Trust, we have conceptualised a plan to secure some 23,000 ha of critical biodiversity across the Soutpansberg mountains through both additional land purchase, as well as through stewardship with existing landowners.

Being landowners ourselves provides us the opportunity to model effective land management that improves and maintains the conservation value of the land. At the same time, we are exploring options to unlock the economic opportunities that such properties have to offer for our neighbouring communities. This will build on the environmental value of the land and the wildlife economy and demonstrate firsthand that conservation and humans livelihoods can be mutually sustainable. By securing land of high conservation value, and integrating business opportunities that provide a financially sustainable framework to secure the land, we will be a model for conservation landscapes at a time where conservation land is often considered unused and unimportant.



Medike Nature Reserve

The EWT and land reform

Land reform and expropriation without compensation became topical issues in 2018. From a conservation perspective, the EWT is less concerned about who owns the land than how it is managed. We support efforts to restore equitable access to land for all South Africans, provided that such efforts do not undermine conservation progress to date, or lead to losses of wildlife and habitat. We recognise that land reform, if undertaken in a legal and structured manner, will allow for new relationships between the EWT, individuals and communities, which will open conservation opportunities for habitat and species. Our involvement in the Biodiversity Stewardship Programme across South Africa positions us to play a positive and valuable role in the land reform space. We have begun exploring opportunities in respect of land reform with the Department of Agriculture, Forestry and Fisheries, as well as key financial institutions, looking at ways for the EWT to support emerging farmers and extend improved support to commercial and communal farmers with whom we work.

Trailblazing a journey to protect South Africa's unique and often overlooked species

South Africa is one of the most biologically diverse countries in the world. If we strategically and carefully govern our development processes, we can achieve sustainable economic growth while ensuring the conservation of our unique natural heritage. Unfortunately, the Environmental Impact Assessment (EIA) Regulations (2014) and process have proven to be both ineffective and inefficient in a number of ways. This has led to the loss and degradation of highly threatened habitats, the wildlife living there, and the ecosystem services they provide. Thanks to Rand Merchant Bank's generous "Trailblazer Grant" support, we have embarked on an ambitious project to address the challenges associated with irresponsible development. Through

the establishment of a strategic national task team of voluntary participants, we will pool this wealth of knowledge, and the influence of multiple organisations, to generate a groundswell towards affecting change. Our approach will be guided by strategic stakeholder workshops, end-user negotiation, and policy level discussions. Our aim is to identify aspects of the current legislation that require urgent amendment, and seek strategic solutions and feasible alternatives to key shortfalls in the process. The successful implementation of our project will lead to a systemic improvement in the functioning and efficiency of EIAs. Ultimately, we will afford better protection to sensitive species, priority habitats, and important ecosystem services.

Providing a greater support role for protected areas

Over recent years, protected areas have become increasingly dependent on external funding and support, with many benefiting from assistance from NGOs and volunteer organisations. During 2018, the EWT helped several protected areas, including Pilanesberg National Park, Kruger National Park, Addo Elephant National Park, and Balule Private Game Reserve, among others. Our assistance included training and support in the use of new technology (Cmore patrol optimisation), jointly raising funds to acquire resources for conservation efforts, providing technical guidance and expertise on a range of specialist subjects such as population management and human-wildlife conflict, and conducting targeted actions for threatened species, such as African Wild Dogs. We have initiated discussions with other like-minded organisations whose revolutionary technology will be able to further assist these areas in real-time with a broad spectrum of initiatives. We are committed to providing continued and expanding support for protected areas into the future.



Wild Dog with pup at Mkhuze

THE VOICE OF THE EWT



The EWT Marketing and Communications Department is the connection between the work of the EWT and the outside world. We are custodian of the brand – the voice of the organisation – both internally and externally, and we bring life to our strategy and culture.

The department works in collaboration with all EWT staff to create a unified voice for the organisation. This translates into increased brand awareness and enhanced reputation through engaging authentic content. Internally, we act as the go-to department, creating a cohesive culture of storytelling and increasing support for programmes through improved communication.



ENDANGERED WILDLIFE TRUST
Protecting forever, together.

A fresh look

Through our partnership with Artifact Advertising, we undertook a strategic repositioning of the EWT brand. To date, this has included a refreshed logo and corporate identity. The updated logo has retained the EWT's Cheetah iconic pawprint, which holds a great deal of brand equity,

but has taken on a more modern look and feel, with the removal of the placeholder box and web address, and the introduction of a simpler font. We have also introduced a new tagline, "Protecting forever, together," in keeping with the EWT's core values, which we include in the logo where applicable.

The updated corporate identity guidelines provide for more latitude in the application of the logo, allowing for a move away from the red pawprint and the introduction of other colours where this works in specific material. The red pawprint remains our primary logo.

The EWT website

The brand refresh includes the development of a slick new website, which will act as both a portal for valuable information, and an easy and effective donation channel. This work will be completed in the second quarter of the next financial year.

During the period under review, our website attracted in excess of 25,000 views. The Mammal Red List page, along with the staff and vacancies sections, were consistently the most visited part of the website during the reporting period.

See www.ewt.org.za

Social media

Social media continues to be a very effective communication medium for the EWT, with the number of followers growing at a steady pace. Facebook remains our most popular social media platform, with 31,345 fans as at 30 June 2018 (up from 26,440 fans at the beginning of the reporting period), and we have maximised this opportunity by utilising Facebook advertising effectively.

Our most popular post during the reporting period related to the movement of Wild Dogs to Gorongosa National Park in Mozambique. This post reached more than 66,000 people, and is evidence of the public's interest in our work on the ground.



Award winning campaigns

An updated and improved approach to our messaging is included in this strategic repositioning, and three core pillars identified to guide all content and visuals. These are Hope, Connection and Purpose. This has underpinned the development of a number of impactful campaigns, in conjunction with Artifact, during the period under review. Artifact continues to offer over R1,000,000 in billable hours annually, at no charge to the EWT.

Our partnership with Artifact has resulted in not one, but two, of our campaigns winning Orchid awards during the year under review. The first of these invited the public to see the animal behind the commodity, and focused on commonly traded species such as pangolins, elephants and rhinos. This campaign was used for print adverts and filled a section of the branding space that we received at no charge from Kruger Mpumalanga International Airport.



The second campaign tackled the reality of cub petting, with taglines such as “killing me softly” and “your kindness is killing me.” These visuals were used in print adverts, and roadside billboards in Johannesburg, Pretoria, and Cape Town, as well as a digital billboard in Durban’s King Shaka International Airport. We have built on this campaign, which will form part of a bigger body of work in the next financial year.

The EWT in the media

The EWT enjoyed extensive media coverage during the reporting period, including features and mentions in print, online and the broadcast media. For the first time, the majority of our coverage came from publications in the United States. This is consistent with the large number of syndicated articles that appeared thanks to Associated Press.

Mentioned in over
2,000
articles (print & online)

More than
40
radio & T.V
interviews

Estimated Advertising Value
Equivalent (AVE) of coverage
for July 2017 – June 2018 =
>R10 million

Most frequent repeat
publishers: IOL,
Bizcommunity.com, Agri
Orbit, Associated Press,
and Traveller24

Countries where coverage was received:



United States
42.74%

Canada
3.66%

Australia
0.84%

Hong Kong
0.58%

South Africa
26.48%

India
1.41%

Zimbabwe
0.71%

United Kingdom
21.85%

Brazil
1.09%

Germany
0.64%

73%
of mentions of
the EWT are on
social media,
22% are in online
publications, & **5%**
in print publications

Sharing our work

We continued to share our work through our electronic newsletter, *ChitterChatter*, and printed magazine, *Conservation Matters*. Six issues of *ChitterChatter* and four issues of *Conservation Matters* were distributed during the period under review.

The reach of *Conservation Matters* increased substantially through the kind support of Media Support Services, who distributed 2,000 copies of each issue to various key locations at Johannesburg’s OR Tambo and Lanseria international airports, at no charge.

Enabling our work

We are grateful to Insight Publishing, who again provided pro bono advertising space in *Who’s Who*.

Ad Outpost continues to be an important supporter, providing the EWT with billboard space in key locations in Johannesburg, Pretoria and Cape Town during the financial year. The approximate value of this support is in excess of R250,000. We also received prime billboard space on the N1 between Johannesburg and Pretoria, with all flying and printing costs sponsored by Conscious Colab.

MARKETING & COMMUNICATIONS TEAM



Belinda Glenn
Marketing and
Communications Manager



Joel Thosago
Senior Marketing
Administrator

Your kindness is killing me.

The cute cubs you pet could grow up to be killed for trophies. **Keep our lions wild.**

SMS "SAVE" to 31913 to donate R15



ENDANGERED
WILDLIFE TRUST

Killing me softly.

The cute cubs you pet could grow up to be killed for trophies. **Keep our lions wild.**

SMS "SAVE" to 31913 to donate R15



ENDANGERED
WILDLIFE TRUST



FUNDING OUR WORK



Revenue streams

With an income of R52,129,622, this was the second-highest annual income generated in the history of the EWT, exceeded only by our 2016/7 income. We attribute this slight drop primarily to the successful conclusion of two of our largest projects, funded by the European Union and the US State Department Bureau of International Narcotics and Law Enforcement Affairs. Otherwise, trusts and foundations income increased 30.5% in 2018, while corporate income also increased 8.4 % year-on-year.

Foundational income continues to represent the EWT's most important income stream for project work, contributing 52.9% of our 2018 revenue, which is largely unchanged from 2016 / 2017, and is a significant increase on previous years (30.6% in 2014 and 34.7% in 2015). Corporate income accounted for 25.9% of our total income, a similar percentage to the previous two years.

The percentage of income generated through different sources remained relatively stable year-on-year from 2016 until 2018.

A large individual grant inflated this income stream in 2017, while proportionately 2016 and 2018 income streams were remarkably similar.

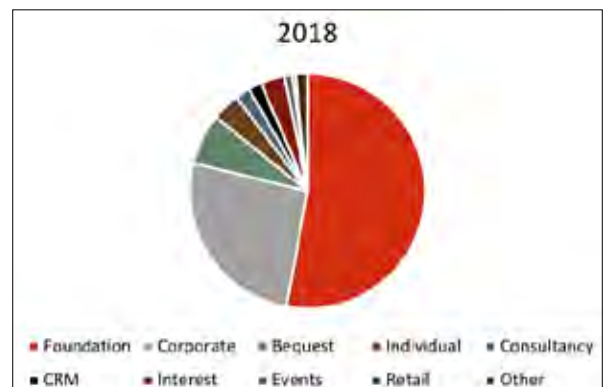
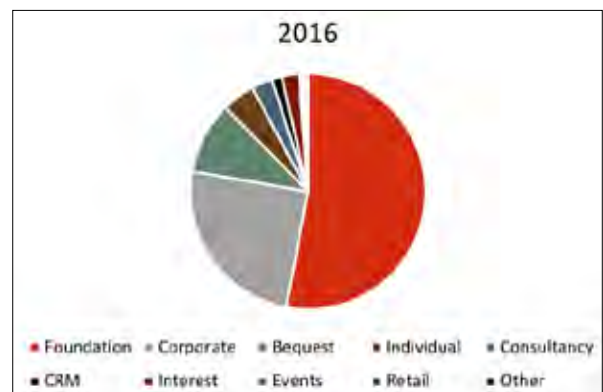
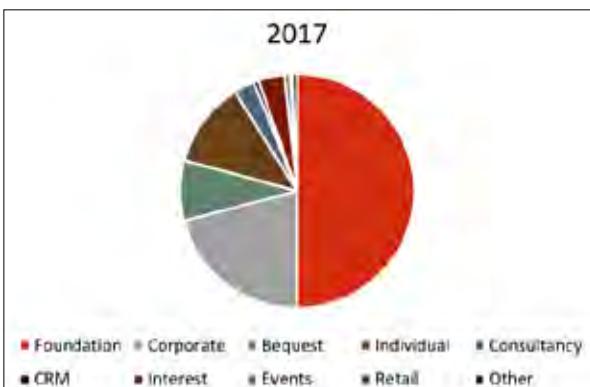

Corporate giving

Corporate giving remains an important means of securing income to support the groundbreaking work of the EWT. Our Business Development Department works tirelessly to secure new corporate clients, and retain our established clients, by ensuring that we build and maintain mutually beneficial relationships. We saw a strong focus on Return on Investment (ROI), and the Sustainable Development Goals (SDGs) during this reporting cycle, with the EWT strengthening its monitoring and evaluation mechanisms. In addition to the ROI and SDG reports, the EWT has a 95% Socio-Economic Development (SED) rating. This allows South African corporates to receive their full five SED points on their B-BBEE scorecard. The EWT is also able to offer an 18A South African tax exemption certificate for corporates who give bona fide donations.



Our loyal supporters

Our loyal members continued to provide generous financial support, through both membership dues as well as donations. We have noted an increase in supporting the EWT through ad hoc donations for projects and specific activities and a down turn in annual membership dues. As a result, we have begun the process of phasing out formal membership and encouraging regular donations. Individual donations include important support through funding channels such as GivenGain (R411,155) and MyPlanet (R251,604), which offer our supporters easy and accessible ways to make a donation. In addition, the EWT continues to manage and host the MyPlanet Rhino Fund income.

Foreign versus local income

Foreign income decreased in the last year due to the closure of two large projects, namely "Natural Resource Conservation and Management for the Generation of a Water-linked Green-economy in the Eastern Cape and Southern KwaZulu-Natal," and "Improving South African Transnational Organised Wildlife Crime Investigations by Strengthening Enforcement and Judicial Capacity," which had been funded by the European Union and the US State Department Bureau of International Narcotics and Law Enforcement Affairs respectively.

We were able to offset this cyclical drop in foreign income through an improvement in our income generation from donors within South Africa, which increased from R35,940,638 to R40,365,161 year-on-year, and R29,486,915 in 2016, representing the most rand income we have received through any financial year.



The percentage of foreign income, compared with rand income, in 2018. We recorded our highest ever rand income through the year.



Conservation talks

The informative and entertaining conservation talks we hold monthly at the Country Club Johannesburg continue to be well supported. We held ten talks this year with topics including the conservation of reptiles, amphibians and carnivores to mention a few. With an average of 72 attendees at each, the most popular talk was Clive Walker’s new book launch, which had a record number of attendees at 142.

Relate bracelets

Through the sale of our Endangered species Relate bracelets, as well as an exclusive EWT Trappers bracelet, we continue to raise valuable funds for the Trust. Once again, our Rhino bracelet proved to be the most popular, followed by our Wild Dog and Cheetah bracelets. The EWT-Relate partnership not only raises money for the EWT but also employs and empowers women, the elderly, township youths, and refugees. The bracelets are available from our online shop (www.ewtshop.co.za), as well as selected Trappers stores and retailers. This year we raised R348,440 through the EWT-Relate partnership.

Special events

Traditionally, the EWT has hosted two fundraising events annually, namely the Telkom 947 Cycle Challenge and the EWT Annual Golf Day. The Cycle Challenge was held on 19 November 2017, with the EWT registered as a charity bond. The EWT’s 2018 Annual Golf Day proved to be our most successful to date, generating a profit of R330,000. The event sold out within three weeks, with 144 players participating, including the likes of John Robbie and Albert (Toks) van der Linde, as well as a host of other famous and philanthropic individuals.

Walking the retail talk

In the spirit of ‘Walking the Talk,’ we added two new branded products to our retail shop which aim to reduce environmental impact. These were a stainless steel straw and a ceramic coffee travel mug and they form part of our ‘Reduce single-

use plastic campaign,’ which launched on Earth Day. Our top sellers remain the fluffy toys. Proceeds from all items sold in the shop go directly to support the work of the EWT.



Bequests

Bequests continue to form an integral part of our funding stream and we are incredibly grateful to those that included the EWT in their will as part of their legacy. By remembering us in their wills, the below benefactors have helped us to achieve our conservation goals, for which we are very grateful.

We received R3,463,063.46 from the following individuals during our 2017/2018 reporting period:

- Late NCG Hilterman*
- Late PRW Crawshaw*
- Late EL Murrell*
- Late KBI Allen*
- Late JHM Yule*
- Late M Halbekath*
- Late V Dohmeier*
- Hans Hoheisen Charitable Trust*

FUNDRAISING TEAM



Dr Tim Jackson
Senior Technical Writer



Claire Patterson-Abrolat
Senior Technical Writer



Tammy Baker
Business Development Officer



Frank Jackson
Business Development Officer

OUR PASSIONATE PEOPLE



The Human Resources team works to support the EWT's Mission and Vision by fostering a healthy, progressive, equitable work environment that will attract and retain excellent employees and enable them to develop to their full potential.

HR operations

Year on year, the EWT's total personnel numbers saw a small increase from 92 to 96. This involved an increase of programmatic staff from 78% to 80% of total personnel, with a concomitant reduction of Support Services staff from 22% to 20% of the total staff complement.

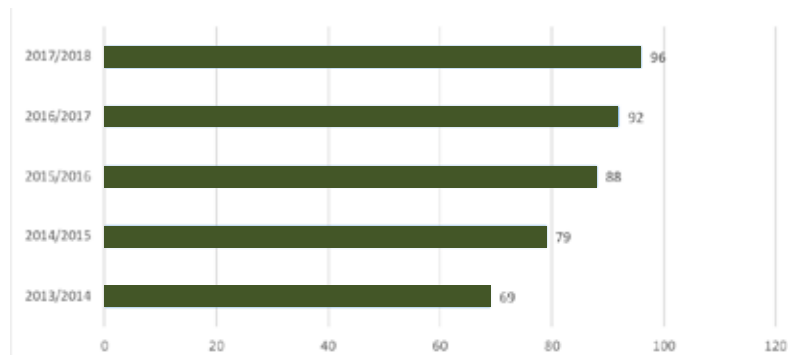

Trends in the total number of personnel



Field	
Programme Executives Snr Managers	03
Programme Managers	16
Programme Senior Field Staff	18
Programme Field Staff	21
Programme Administrative Staff	03
Assistant Field Officer	03
Programme Intern	13



Position and number of people

HQ (SS)	
Support Services Management	03
Support Services Staff	11
SS Interns	01
SS Executive Management	04



Total staff numbers: 96

Personnel split between Support Services and Field Operations

Workforce demographics

The EWT's multicultural and multigenerational team of highly talented individuals continues to be our most valuable resource. Our commitment to inclusion and diversity ensures we are on the right path to achieving our employment equity goals. We remain committed to recruiting quality people and developing their potential through our focus on creating a learning culture, thus enhancing their careers and maintaining our competitive edge.

	AGE				DISABLED		RACE TOTAL
	19-35		36-65		FEMALE	MALE	
	FEMALE	MALE	FEMALE	MALE			
AFRICAN	6	16	7	7	0	1	37
COLOURED	2	0	3	1	0	0	6
INDIAN	0	1	1	0	0	0	2
WHITE	9	10	20	0	2	1	51
GRAND TOTAL	44		48		4		96

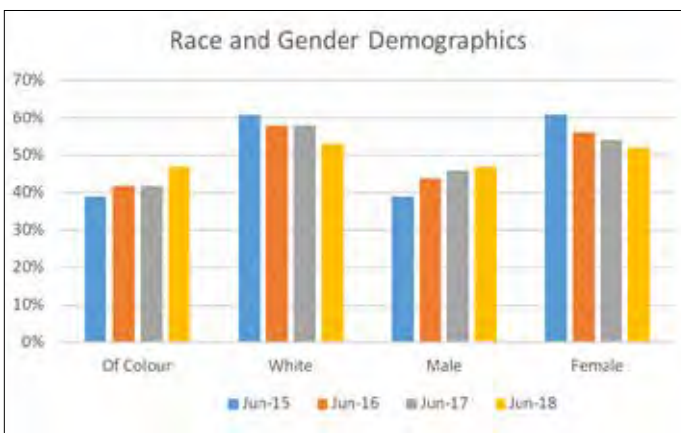

Trends in race and gender demographics of EWT staff



Employment equity

The EWT's employment equity plan aims at eliminating barriers that have a negative impact on attraction, development and retention of employees, particularly from designated groups. The table below compares our progress towards achieving our targeted demographic breakdown, against our actual demographic figures as at 30 June 2018. All targets were achieved barring that of African females, which is well below target and requires a concentrated effort to rectify, with the other area of shortfall being within the numbers of total female employees. In an effort to rectify this, a succession plan to enable the increase in these areas will be put in place during the next reporting cycle.

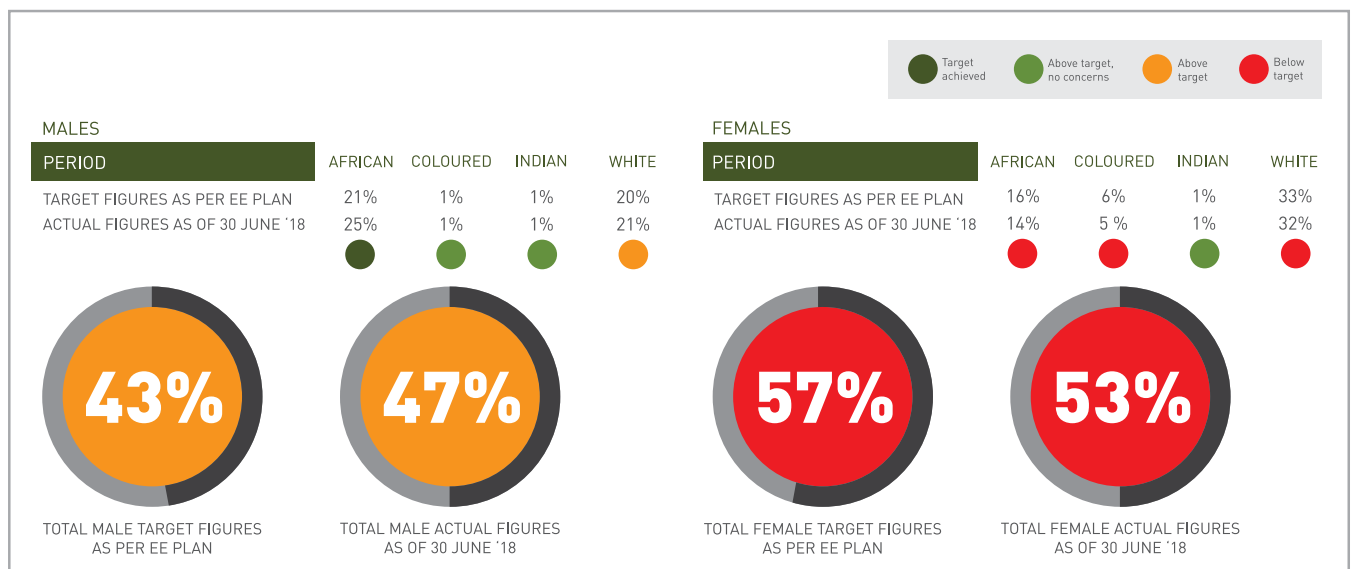

Employment Equity figures: Target vs actuals



Trustee demographics

There were no changes in our trustee demographics from the previous reporting cycle to this one.

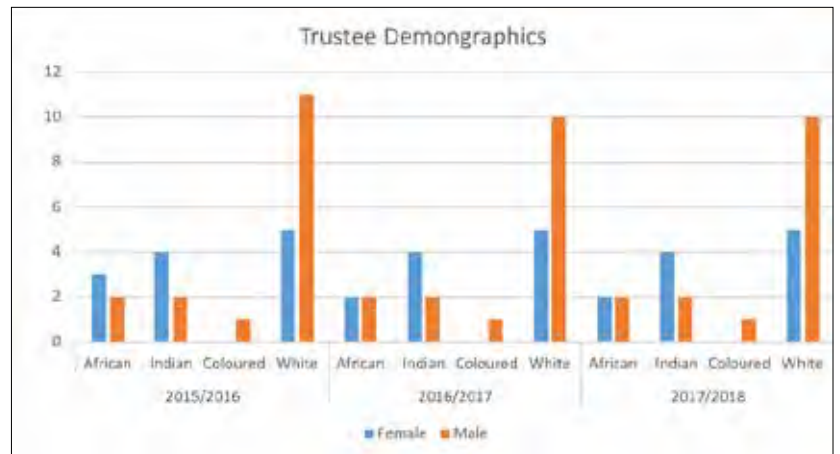

Trustee Demographics





Talent management

It remains the philosophy of the EWT to promote and recruit from within the organisation, where possible. The benefits reaped from this practice include increased employee morale, while this also contributes to lower training and onboarding costs. However, during this reporting period, the opportunity for internal recruitment was lower than in previous years. This was due to the need to source new skill sets that matched the requirements of the projects and programmes we took on. Two internal promotions were awarded during the period under review.

Learning culture

The EWT places a high premium on employee development and training, as these activities are an important priority for organisational effectiveness.

• Internships

The EWT hosted a total of 15 interns in the past year, one of whom has subsequently accepted a full-term position within the EWT, one has chosen to return to full-time studies, and 13 remain with the EWT on their internships.

• Student facilitation

The EWT prides itself on being able to facilitate student projects within its programmes, which is beneficial for both the students and the EWT alike. The following programmes hosted students during this reporting period:

• Training

Training presents an opportunity for staff to develop new skills, allowing for the growth of the EWT as a whole, our personnel's growth, and the growth of select external individuals whom we support through bursaries, who have a passion for conservation but do not have the means to pursue their passion. As such, the EWT invested R1,211,773 on a variety of training initiatives, in which our staff and students participated during the period under review e.g. Computer Literacy, Internship and Learnership training, English for basic communications, Provisional and Drivers' Licences, degree and diploma courses and various other short courses. These training opportunities were facilitated by the holding of our 14th annual Conservation Week and 9th annual Development Week in November 2017 and June 2018 respectively. The aim of these contact weeks is to reinforce our learning culture by providing our personnel with the space to ask questions, share successes and lessons learned, and to propagate and cross-fertilise ideas. It further allows individuals to reflect on the success of others and the EWT as a whole, allowing them the opportunity to share how their individual achievements have contributed to the overall success of the EWT.

Students aided by the EWT per programme and their areas of study

Programme	Degree	Area of studies
African Crane Conservation Programme	PhD	Population status and factors affecting the conservation and survival of Grey Crowned Crane
Birds of Prey Programme	BTech	Grass Owl road mortalities
Wildlife and Roads Project	BTech	Nature conservation
Wildlife and Roads Project	BTech	Assessing driver behaviour
Wildlife and Roads Project	MSc	Roadkill in protected areas
Wildlife and Roads Project	MSc	Roadkill in protected areas
Carnivore Conservation Programme	Diploma	Nature conservation
Wildlife in Trade Programme	MSc	Predictive modelling and decision support for counter poaching operations

Corporate social investment

The EWT believes that corporate social investment (CSI) contribution is a moral imperative for South African organisations. Therefore, we actively seek opportunities to incorporate CSI into our conservation-related activities. Over the reporting cycle, we have seen an increase in our CSI activities from 757 interactions to 1,529, and a concurrent increase in the number of individuals we reached, from 37,786 individuals last year to 59,334 individuals during this reporting period. We attribute this significant increase largely to the number of students reached.

Our activities included Wildlife Poisoning Intervention Training, Rodent Control Training, Computer Training, Nature Site Guide Training, Healthy Environment Workshops and many others. These activities focus on disseminating activities and/or information which we hope will result in behaviour changes that benefit both the communities and the environment.

The number of EWT's CSI initiatives carried out by our flagship projects in key focus areas

	Number of interventions	Number of people reached
Community training, skills development for unemployed people – decent work and sustainable livelihoods – community training, skills development for unemployed people and adult basic education and training.	210	1,860
Support of education programmes, resources and materials at a primary, secondary and tertiary level.	1,248	56,200
Support of health care and HIV/AIDS programmes.	15	250
Rural development – development programmes for women, youth, people with disabilities and people living in rural areas.	15	382
Support of arts, cultural or sporting development programmes.	6	40



Organisational sustainability

Broad-Based Black Economic Empowerment

The increase in our annual turnover for the previous fiscal year saw the EWT reporting within a higher B-BBEE category, namely the Generic Enterprise Category. This resulted in a level six rating certificate being awarded for the audited period of June 2016/17, with the certificate being valid for the period November 2017/18.

Socio-Economic Development Certificate (SED)

The EWT received a 100% rating for our Socio-Economic Development Certificate for the seventh consecutive year. This means that EWT supporters can recognise 100% of the value of their sponsorship in the calculation of their own scorecards.

HUMAN RESOURCES TEAM



Alison Jânicke
Head of Resource
Development



Emma Chisare
Human Resources Assistant



Precious Morgan
Receptionist



Sizakele Ntsele
Office Administrator &
Catering



Dorah Mncube
Housekeeper



Thembi Mlimi
Housekeeper

GOVERNANCE

Ensuring good governance

The EWT is a registered Trust governed in accordance with the Trust Property Control Act No. 57 of 1988, under Master's reference number IT 6247. The Amended and Restated Deed of Trust 2014, as registered with the Master of the North Gauteng High Court in Pretoria, is the founding document of the EWT and lays out the roles and responsibilities of Trustees, the Board and the committees of the Board. EWT Trustees are not remunerated for their services and serve the EWT in a voluntary capacity.

Annual General Meeting

The AGM of the Trust took place on 9 November 2017, at the EWT Head Office in Modderfontein.

The EWT Board was re-elected in its entirety, with Dirk Ackerman, Paul Smith and Uwe Putlitz continuing as the office

bearers; Chair, Treasurer and Deputy Chair, respectively. In addition, four Trustees were appointed as new Board members, namely:

1. Barry Ackers;
2. Sharmila Govind;
3. Veniela Pillay; and
4. Lesego Rammusi.

The Board now consists of thirteen Trustees, including the CEO as an ex officio member. Lavinia Khangala and Andrew Johnston tendered their resignations as Trustees in February and May 2017, respectively, bringing the total number of trustees to 26. These resignations were ratified at the AGM.

The Trustees voted to retain Deloitte as the auditors of the Trust.

Board and committees

As per the Trust Deed, the Trustees appoint the Board at the AGM to administer the affairs of the Trust on their behalf.

The Board met five times over the course of the financial year. Of these, four meetings were regular Board meetings, and one was an Extraordinary Board meeting concerning property purchase decisions of the Trust. The Board undertook activities in accordance with its Charter and to fulfil its work plan, which is developed and adopted annually on a calendar-year basis. At the end of the year, the Board evaluates its own performance in relation to its work plan for the year.

In September 2017, The Institute of Directors South Africa (IoDSA) sponsored the EWT's annual Board evaluation, making it the first externally-moderated review of the Board's performance. The review analysed the Board composition, the Board's responsibilities, committees of the Board, Board and committee meetings, and the Board's relationships with management and other stakeholders. It resulted in an excellent scorecard for our Board across the various categories that were assessed, and was a smooth, professionally run process. The EWT has taken cognisance of the areas where we can score even higher in the future, and how we can aspire to better the performance, despite it being excellent overall. The EWT would like to extend its thanks to IoDSA for sponsoring this Board evaluation.

Following the March Board meeting, the Trustee Procurement and Conflict of Interest Policy was amended and is now titled, "Trustees, Board and Board Committees Procurement and Conflict of Interest Policy." The EWT Board Charter was also amended to give further clarity as to addressing certain conflicts of interest. It is also specifically noted that the Board Charter is to be read in line with the EWT Amended and Restated Deed of Trust, and the Trustees, Board and Board Committees Procurement and Conflict of Interest Policy.

The Board appoints committees of the Board to assist the Board in the administration of the affairs of the Trust.

Board meeting attendance during the period 2017-2018

Key – Green: attended; Grey: not yet appointed; and Red: apologies

BOARD MEETING ATTENDANCE DURING THE PERIOD 2017-2018						
		● Attended ● Not yet appointed ● Apologies				
BOARD		13-09-17	28-11-17	12-02-18	29-03-18	28-06-18
Mr Dirk Ackerman - Chairperson		●	●	●	●	●
Mr Uwe Putlitz - Vice Chairperson		●	●	●	●	●
Mr Paul Smith - Treasurer		●	●	●	●	●
Mr Anthony Diepenbroek		●	●	●	●	●
Prof Barry Ackers		●	●	●	●	●
Mr Mike Esterhuysen		●	●	●	●	●
Ms Sharmila Govind		●	●	●	●	●
Ms Joanna Goeller		●	●	●	●	●
Ms Karin Ireton		●	●	●	●	●
Mr Lot Mlati		●	●	●	●	●
Dr Veniela Pillay		●	●	●	●	●
Ms Lesego Rammusi		●	●	●	●	●
Mr Antony Wannell		●	●	●	●	●
Ms Yolana Friedmann - CEO - ex officio		●	●	●	●	●
In attendance - Ms Mandy Poole - COO		●	●	●	●	●

Audit and Finance Committee

The Audit and Finance Committee (AFC) is an official Board sub-committee established under Clause 23.1 of the Amended and Restated Deed of Trust 2014. It is chaired by Paul Smith in his capacity as Treasurer. It adopts an annual work plan for the calendar year and self-evaluates at the close of the year. The AFC met four times during the financial year to fulfil its financial oversight responsibilities to the Board and the Trust, in particular the approval of the annual budget for the financial year and continual monitoring of performance against this budget.

The AFC, and the EWT as a whole, are grateful for the support of Deloitte in the carrying out of the organisation's annual financial audit.

Audit and Finance Committee meeting attendance during the period 2017–2018.

Key – Green: attended; Grey: not yet appointed; Yellow: resigned; and Red: apologies.

AFC	21-08-17	23-11-17	22-03-18	25-06-18
Mr Paul Smith – Treasurer and Chairperson – ex officio	●	●	●	●
Prof. Barry Ackers	●	●	●	●
Mr A K Mohamed	●	●	●	●
Mr Neil Morris	●	●	●	●
Ms Lesego Rammusi	●	●	●	●
Mr Muhammad Seedat	●	●	●	●
Mr Antony Wannell	●	●	●	●
In attendance – Ms Yolana Friedmann – CEO	●	●	●	●
In attendance – Ms Mandy Poole – COO	●	●	●	●

Social, Ethics and Remuneration Committee

The Social, Ethics and Remuneration Committee (SERC) was due to meet twice over the course of the financial year, in November 2017 and May 2018. The first meeting took place as planned, with the second meeting being rescheduled for July 2018. The SERC works to an annual work plan. Following on the full review of the EWT's pension fund undertaking in the financial year 2016–17, the SERC recommended, and the Board approved, the dissolution of the EWT Liberty Life Pension Fund. The EWT provided staff with expert guidance on reorganising their investments for retirement.

Social Ethics and Remuneration Committee meeting attendance during the period 2017–2018.

Key – Green: attended; Grey: not yet appointed and Red: apologies.

SERC	23-11-17
● Attended ● Not yet appointed ● Apologies	
Mr Mike Esterhuysen	●
Ms Sharmila Govind	●
Ms Karin Ireton	●
Mr Paul Smith	●
Mr Antony Diepenbroek (guest)	●
Dr Ven Pillay	●
In attendance – Ms Yolana Friedmann – CEO	●
In attendance – Ms Mandy Poole – COO	●
In attendance – Ms Alison Jänicke – Head of Resource Development	●

Involvement of Trustees in the EWT

	Board	Audit & Finance Comm.	Social Ethics & Remuneration Comm.
Mr Dirk Ackerman	●		
Prof Barry Ackers	●	●	
Mr Anthony Diepenbroek	●		
Mr Mike Esterhuysen	●		●
Ms Joanna Goeller	●		
Ms Sharmila Govind	●		●
Ms Karin Ireton	●		●
Dr Anusha Lucen			
Mr Lot Mlati	●		
Mr AK Mohamed		●	
Ms Ven Pillay	●		●
Mr Uwe Putlitz	●		
Ms Lesego Rammusi	●	●	
Mr Muhammad Seedat	●	●	
Mr Paul Smith	●	●	●
Ms Kiyasha Thambi			
Mr Antony Wannell	●	●	

Other Trustee matters

Many Trustees continue to be involved in the Trust in a variety of ways, ranging from serving on formal committees of the Trust, to serving on the programme Technical Advisory Committee (TAC), assisting with fundraising and property related matters, and mentoring members of staff.



Agreements

The table below records the number and type of agreements entered into by the EWT over this financial year, with comparative figures for the previous financial year.

Type of agreement	Agreements signed 1 July 17 to 30 June 18	Agreements signed 1 July 2016 to 30 June 2017
South African sourced grant agreements	11	8
International sourced grant agreements	10	18
Sub-grant agreements (where EWT sub-grants)	2	12
Contractor's agreements (where EWT is hired as an independent contractor)	13	24
Contractor's agreements (where EWT hires an independent contractor)	22	9
Collaborative agreements (with funding to EWT)	2	1
Collaborative agreements (with funding from EWT)	6	5
Collaborative agreements (no funding)	5	19
Cause-related marketing (CRM) agreements	7	6
Logo use undertakings	7	20
Temporary custodianship agreements	1	4
Other	25	14
Total number of agreements	111	140

Internal structures

Executive Management Team

The EWT Executive Management Team consisted of Yolán Friedmann, (CEO and Chairperson), Mandy Poole (Chief Operations Officer), Dr Harriet Davies-Mostert (Head of Conservation), Alison Jänicke (Head of Resource Development), Kerry Morrison (Senior Programme Manager: Africa), and Dr Ian Little (Senior Programme Manager: Habitats). Xolani Klaas (Finance Manager) left the organisation in October 2017. The team met approximately every three weeks – 12 times during the financial year – and discussed strategic matters, focusing on issues such as governance and compliance, financial performance, resource development – human and financial, physical infrastructure – building, equipment and operations including IT and communications and branding; partnerships; and new ventures.

Conservation Management Team

The EWT Conservation Management Team (CMT) met 11 times during the financial year. Support Services and Programme Managers attend these meetings, where the focus is on conservation, research, strategic and programmatic issues. Matters discussed include programme and project management, conservation strategy, ethics, data sharing, science and research, partnerships, new projects and regional field offices. Financial wellbeing and sustainability are also discussed from a programme/project perspective. Where field-based managers are unable to attend the CMT, the EWT uses the Zoom™ software platform to provide staff with the ability to participate remotely in these crucial meetings by audio and/or video conferencing.

Ethics Committee

The CMT plays a vital role in the EWT's commitment to carrying out its science-based, conservation activities on a sound ethical basis. It functions informally as the EWT's Ethics Committee and ethical issues are a standing item on the monthly agenda for the CMT meetings. Proposed new projects are introduced in this forum and discussed in detail, with particular attention

being paid to ethical considerations, before a final decision as to whether or not to proceed is taken. Two ethical evaluations were conducted during the financial year, concerning conservation activities around:

- The conflict between crows and Leopard Tortoises, as part of the Wildlife and Energy Programme Leopard Tortoise Project; and
- Imprinting of sniffer dogs on pangolin scales.

Conservation Forum

The EWT Conservation Forum (CF) met ten times in the course of the financial year. The CF provides a forum for information sharing between field and head office-based staff and seeks to promote a greater understanding of others' portfolios of work. Guest speakers often attend to raise awareness of issues not within the EWT's fields of expertise. These meetings are for all staff, and in 2018, the EWT also began producing podcasts of CF meetings, for staff to listen to in the event that they are unable to attend CF.

Policies

The EWT continually reviews its internal policies and procedures, to ensure that the Trust is compliant with all external and statutory requirements.

Of significance to the EWT is the European Union (EU) General Data Protection Regulation (GDPR), which came into force on 25 May 2018. An entity based outside the EU is required to comply with the GDPR if that entity offers free or paid goods or services to EU residents. The EWT has amended its Protection of Personal Information policy to this effect.

In the financial period under review, Cliffe Dekker Hofmeyr has provided invaluable assistance, in particular in property-related matters.

Risk mitigation and assessment

RISK AREA – ALPHABETICAL ORDER	RISK DESCRIPTION	KEY 2017-2018 ACTIONS
1 Compliance – Statutory & Non-statutory	Non-compliance with laws, best practices and/or internal policies	The EWT has amended its Protection of Personal Information policy to be in line with the European Union General Data Protection Regulation. Changes include a specific definition of what constitutes consent, record keeping requirements, and clearer wording around the EWT’s responsibilities, with respect to local and international transfer of personal information.
2 External Relationships and Environment	Poor stakeholder relations and/or adverse economic, political and social factors	The EWT has procured and is in the process of rolling out a comprehensive stakeholder relations management (CRM) system to enable the EWT to track customer interaction, and develop real-time data and reports.
3 Financial Management	Inadequate management of budgets, assets and key financial recording systems	<ul style="list-style-type: none"> The EWT has retained the services of an external consultant on a retainer contract to develop the EWT internal audit function, and to provide other key financial expertise as required. In addition, the EWT has implemented more rigorous controls around its online banking functionality, i.e.: <ul style="list-style-type: none"> o scrutiny and segregation of duties surrounding the loading and approval of payees, and o the loading and approval of payments. The EWT has also recognised the need to implement a new finance system and will be pursuing this in the next year.
4 Marketing (Fundraising) Effectiveness	Inadequate funding pipeline for projects and support services	<ul style="list-style-type: none"> The EWT has hired a Digital Marketer who is responsible for implementing innovative concepts that increase public awareness and brand engagement in support of increasing income to the EWT. We have started the process of developing fundraising plans for all programmes, and are developing a return on investment reporting structure. We have also purchased a new Customer Relationship Management System.
5 Human Resources Management	EWT organisational structure and/or work environment is not conducive to achieving strategic objectives	Introduction of new payroll system for the EWT, with greater reporting capacity and an online employee self-service system.
6 ICT Management	ICT services and hardware are not managed optimally to meet EWT business requirements	The EWT has introduced Cybex, a system to comprehensively back up all data and information on all EWT laptops and machines to the cloud, so as to minimise risk of data loss.
7 Programme Effectiveness	Non-achievement of the EWT’s Vision, Mission and Strategic Objectives	<ul style="list-style-type: none"> Revision of the EWT Strategy in order to maximise programme effectiveness. Strategic Imperatives (our key focus areas) have been reduced from 6 to 3, namely: <ol style="list-style-type: none"> 1. Take action to conserve threatened wildlife; 2. Uphold ecosystem integrity and conserve threatened habitats; and 3. Enable biodiversity-friendly businesses, enterprises and livelihoods. Adoption of the Open Standards for the Practice of Conservation to facilitate more effective performance monitoring and reporting, including reporting to donors and stakeholders.

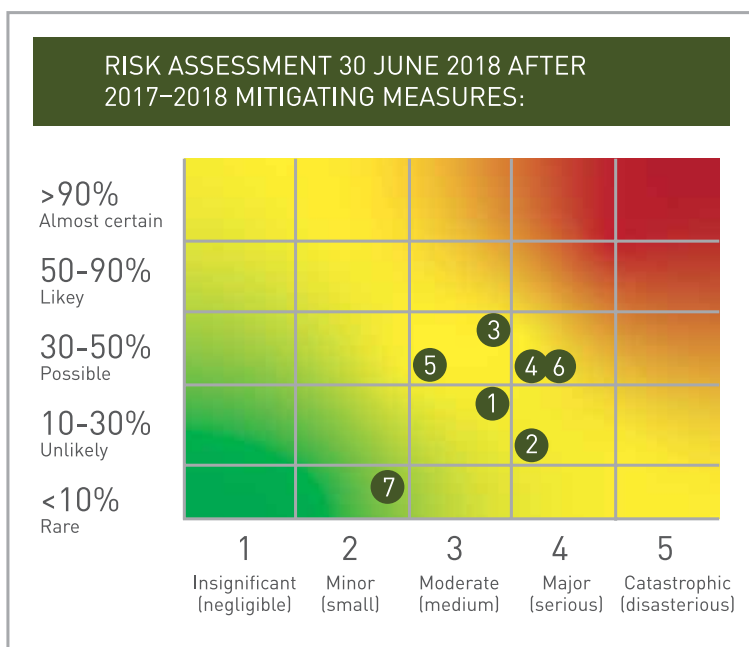

INDEPENDENT AUDITOR'S REPORT ON THE SUMMARY FINANCIAL STATEMENTS TO THE TRUSTEES OF THE ENDANGERED WILDLIFE TRUST

Opinion

The summary financial statements, which comprise the summary statement of financial position as at 30 June 2018, the summary statement of comprehensive income, changes in equity and cash flows for the year then ended, and summary notes, are derived from the audited financial statements of The Endangered Wildlife Trust for the year ended 30 June 2018. We expressed a qualified audit opinion on those financial statements in our report dated 11 October 2018.

In our opinion, the accompanying summary financial statements are consistent, in all material respects, with the audited financial statements, in accordance with the basis of accounting described in note 1 to the financial statements. However, the summary financial statements are misstated to the equivalent extent as the audited financial statements of The Endangered Wildlife Trust for the year ended 30 June 2018.

Summary Financial Statements

The summary financial statements do not contain all the disclosures required by the requirements as set out in note 1 to the financial statements. Reading the summary financial statements and the auditor's report thereon, therefore, is not a substitute for reading the audited financial statements and the auditor's report thereon.

The Audited Financial Statements and Our Report Thereon

We expressed a qualified audit opinion on the audited financial statements in our report dated 11 October 2018.

In common with similar organisations, it is not feasible for the Endangered Wildlife Trust to institute accounting controls over cash collections from subscriptions, donations and fundraising activities prior to the initial entry of such collections in the accounting records. Accordingly, it was impractical for us to extend our examination beyond the receipts actually recorded.

Trustees' Responsibility for the Summary Financial Statements

The Trustees are responsible for the preparation of the summary financial statements in accordance with basis of accounting described in note 1 to the financial statements and the requirements of the Fundraising Act, for determining that the basis of preparation is acceptable in the circumstances and for such internal control as the trustees determine is necessary to enable the preparation of the summary financial statements that are free from material misstatement, whether due to fraud or error.

Auditor's Responsibility

Our responsibility is to express an opinion on whether the summary financial statements are consistent, in all material respects, with the financial statements based on our procedures, which were conducted in accordance with International Standard on Auditing (ISA) 810 (Revised), Engagements to Report on Summary Financial Statements.

Deloitte & Touche

Deloitte & Touche

Registered Auditor
Per: F Coovadia
Partner
11 October 2018

National Executive: *LL Bam Chief Executive Officer *FMM Jordan Deputy Chief Executive Officer; Clients & Industries *MJ Jarvis Chief Operating Officer
*AF Mackie Audit & Assurance *N Sing Risk Advisory *NB Kader Africa Tax & Legal TP Pillay Consulting S Gwala BP5 *JK Mazzocco Talent & Transformation
MG Dicks Risk Independence & Legal *TJ Brown Chairman of the Board

A full list of partners and directors is available on request

* Partner and Registered Auditor

B-BBEE rating: Level 1 contribution in terms of the DTI Generic Scorecard as per the amended Codes of Good Practice

Associate of Deloitte Africa, a Member of Deloitte Touche Tohmatsu Limited

SUMMARY STATEMENT OF FINANCIAL POSITION

as at 30 June 2018

	30 Jun '18 R	30 Jun '17 R
ASSETS		
<i>Non-current assets</i>		
Land holdings	4 100 000	-
Property and equipment	1 946 130	2 344 293
Total non-current assets	6 046 130	2 344 293
<i>Current assets</i>		
Accounts receivable	958 666	1 863 063
E-shop stock in hand	275 682	403 740
Deposit	1 250 000	-
Cash and cash equivalents	19 649 126	32 972 800
Total current assets	22 133 474	35 239 603
TOTAL ASSETS	28 179 604	37 583 896
FUNDS AND LIABILITIES		
<i>Trust funds</i>		
Accumulated funds	9 432 519	10 238 655
Non-distributable reserves	5 475 222	1 484 914
Total Trust funds	14 907 741	11 723 569
<i>Current liabilities</i>		
Accounts payable	707 481	1 236 869
Funds held on behalf of other organisations	1 121 667	3 167 384
Deferred revenue	11 083 524	21 085 915
Leave Provision	359 191	370 159
Total current liabilities	13 271 863	25 860 327
TOTAL FUNDS AND LIABILITIES	28 179 604	37 583 896

SUMMARY STATEMENT OF COMPREHENSIVE INCOME

for the year ended 30 June 2018

	30 Jun '18 R	30 Jun '17 R
Revenue	62 115 383	52 983 709
Expenses	(62 921 519)	(52 783 440)
Total Comprehensive Operational (Deficit)/Surplus for the year	(806 136)	200 269
<i>After charging:</i>		
Depreciation		
Owned and leased assets – charged to income	182 802	105 403
– charged to non-distributable reserves	1 745 914	1 492 669
	1 928 716	1 598 072
<i>and after crediting:</i>		
Interest received – bank deposits	1 741 278	2 252 296
Accumulated funds at beginning of period	10 238 655	10 038 386
Accumulated funds at end of period	9 432 519	10 238 655

NOTES TO THE SUMMARY FINANCIAL STATEMENTS

1. Accounting policies

The financial statements are prepared on a historical cost basis. The following are the principal accounting policies used by the Trust, and are consistent with those of the previous periods.

1.1 Revenue

Gross revenue excludes value-added tax and represents subscriptions, donations, project income and other voluntary contributions. Subscriptions income is recognised on receipt.

Interest received is accrued on a time basis, by reference to the principal outstanding and at the effective interest rate applicable.

1.2 Deferred revenue

Revenue received for specific projects is matched against project expenditure when incurred. Unspent programme revenue is treated as deferred revenue. Deferred revenue relating to completed projects is re-allocated to other projects. Deficits are recouped from other donors or projects.

1.3 Land

Land is included at cost. Land purchased for conservation is charged against revenue upon acquisition. Land is not depreciated.

1.4 Property and equipment

Property and equipment are included at cost. Cost includes all costs directly attributable to bringing the assets to working condition for their intended use.

Depreciation is calculated by a charge to income computed on a straight-line basis so as to write off the cost or amount of the valuation of the assets over their expected useful lives.

The depreciation rates applicable to each category of fixed assets are as follows:

Leasehold improvements	10% straight-line
Other assets	33.33% straight-line

Donated artwork is not depreciated.

Assets purchased for projects are charged against revenue upon acquisition. The related depreciation of these assets is also written down against Non Distributable Reserves.

The gain or loss arising on the disposal of an item of property and equipment is determined as the difference between the sale proceeds and the carrying amount of the asset and is included in income or deficit for the period.

1.5 Cash and cash equivalents

Cash and cash equivalents are measured at fair value and comprise cash on hand, deposits held on call with banks, and investments in money market instruments.

GOVERNANCE TEAM



Mandy Poole
Chief Operations Officer



Ayanda Mkhululi Sibiya
Accountant



Melissa Govindsamy
Senior Bookkeeper



Zakhele Mpungose
Grant Manager



Rugare Nyamhunga
Information and
Compliance Officer

NOTES TO THE SUMMARY FINANCIAL STATEMENTS (CONTINUED)

1. Accounting policies (continued)

1.6 Provisions

Provisions are recognised when the Trust has a present obligation (legal or constructive) as a result of a past event, it is probable that the Trust will be required to settle the obligation, and a reliable estimate can be made of the amount of the obligation.

The amount recognised as a provision is the best estimate of the consideration required to settle the present obligation at the statement of financial position date, taking into account the risks and uncertainties surrounding the obligation.

Where a provision is measured using the cash flows estimated to settle the present obligation, its carrying amount is the present value of those cash flows.

When some or all of the economic benefits required to settle a provision are expected to be recovered from a third party, the receivable is recognised as an asset if it is virtually certain that reimbursement will be received and the amount of the receivable can be measured reliably.

1.7 Financial instruments

Financial assets and financial liabilities are recognised on the Trust's statement of financial position when the Trust has become a party to contractual provisions of the instrument.

Financial assets

The Trust's financial assets are bank balances and cash and accounts receivable.

The accounting policy for bank balances and cash is dealt with under cash and cash equivalents set out in note 1.4.

Accounts receivable are stated at amortised cost.

Financial liabilities

The Trust's principal financial liabilities consist of accounts payable.

Accounts payable are stated at amortised cost.

1.8 Trust funds

The Trust raises funds for future projects which are designated as Special Funds in the Statement of Financial Position. Due to the fact that the future use of these funds is unspecified, Management assesses and releases funds back to the Statement of Comprehensive Income as and when approved by a resolution of the Board. The Trust does not currently hold any Special Funds.

1.9 Eshop products

Eshop products bought are treated as a prepayment and only recognised as an expense when items are sold.

GOVERNANCE TEAM



Yves Manana
Information Technology
Manager



Miranda Kambule
IT Intern

AWARDS & ACHIEVEMENTS

External awards

The following prestigious awards were awarded to the EWT, for our outstanding work carried out in various fields:

Rhino Conservation Award:

The EWT's Wildlife in Trade Programme won the award in the Best Rhino Conservation Supporter category at the 2017 Rhino Conservation Awards.

Mail & Guardian Greening The Future Awards:

The Urban Conservation Programme and the Gauteng Biodiversity Stewardship Project were awarded the Community Conservation and Resilience Award, by the Mail and Guardian Greening the Future Awards.

SANParks Kudu Award:

The Carnivore Conservation Programme, and Vincent van der Merwe in particular, were awarded the SANParks Kudu Award for their dedicated work on the Cheetah Metapopulation Project.

Sunday Tribune 'Amaqhawe' Award:

Thabo Madlala (African Crane Conservation Programme Field Officer), Samson Phakathi (Threatened Grassland Species Programme Field Officer) and Cherise Acker (Threatened Amphibian Programme Field Officer), won Environmental Change Maker awards at the inaugural Sunday Tribune 'Amaqhawe' Awards, for their outstanding commitment to making a difference in their respective fields.

TW Kambule-NSTF Award:

Emerging Researcher: Wendy Collinson won this prestigious award at the National Science and Technology (NSTF) awards for her work in establishing and running the EWT's Wildlife and Roads Project.



Internal awards

Our personnel are regularly recognised for their outstanding achievements. The EWT also acknowledges deserving staff internally through monthly and annual awards. The top achievers for the calendar year ending December 2017 are:

- **Programme of the Year Award:**
African Crane Conservation Programme
- **Programme Manager of the Year Award:**
Cobus Theron – Drylands Conservation Programme
- **Conservation Achiever of the Year Award:**
Grant Beverley – Carnivore Conservation Programme
- **Conservation Supporter of the Year Award:**
Rugare Nyamhunga – Governance
- **Conservation Supporter of the Year Runner-Up Award:**
Ayanda Sibiya – Finance
- **Anatolian (Conflict Resolution Award):**
Samson Phakathi – Threatened Grassland Species Programme
- **Honey Badger (Fiercest Field Officer) Award:**
Emily Taylor – Threatened Grasslands Programme and Eco-Schools
- **Pawprint Brand Ambassador Award:**
Esther Matthew – Drylands Conservation Programme
- **Media Award:**
Wildlife in Trade Programme
- **Self-Improvement Award:**
Frank Jackson – Business Development
- **Newcomer of the Year Awards:**
Oldrich van Schalkwyk (Soutpansberg Protected Area Project) and Innocent Buthelezi (Wildlife and Roads Project)
- **Special Acknowledgement Award:**
Ashleigh Dore – Wildlife in Trade Programme
- **Long Service Award:**
Precious Morgan (ten years) – Administration;
Marion Burger (ten years) – Communications Department;
and Tanya Smith (ten years) – African Crane Conservation Programme



WHO WE WORK WITH

Strategic partnerships

The EWT achieves its significant conservation impacts by collaborating with a host of organisations, including government agencies and parastatals, communities, other NGOs, companies, academic institutions and private individuals. While our current partnerships are too numerous to mention individually, we would like to draw attention to the following overarching strategic alliances and partnerships that were in force over the past year:

- African Parks
- Alliance for Zero Extinction (International)
- APOPO (Anti-Personsmijnen Ontmijnende Product Ontwikkeling, or Anti-Personnel Landmines Removal Product Development in English)
- BirdLife South Africa
- CapeNature
- Community Action for Nature Conservation (Kenya)
- Conservation South Africa
- Conservation International
- Eskom Holdings SOC Ltd
- Ezemvelo KZN Wildlife
- Fauna and Flora International
- Global Biodiversity Information Facility (International)
- Gauteng Department of Agriculture and Rural Development (GDARD)
- Hawk Conservancy Trust
- International Crane Foundation (USA)
- Kitabi College for Conservation and Environmental Management (Rwanda)
- National Department of Parks and Wildlife (Zambia)
- National Zoological Gardens
- Nature Uganda
- Northern Cape Department of Environment and Nature Conservation
- Pathfinder International
- Population Sustainability Network (International)
- Rainforest Trust
- Saving the Survivors
- South African National Biodiversity Institute
- South African National Parks
- The Peregrine Fund
- Wilderness Foundation
- Wildlife and Environment Society of South Africa
- WWF South Africa

In addition, through our action on the ground across most of the country, we work closely with all provincial conservation bodies. Our efforts to ensure that our work is based on sound scientific methods, and contributes to knowledge in the conservation sector, mean that we have forged strong relationships with a diversity of academic institutions, including:

- Alterra Wageningen University
- Boise State University
- Liverpool John Moores University
- Mekelle Biodiversity Center
- North-West University
- Reading University
- Rhodes University
- Tshwane University of Technology
- University of Cape Town
- University of the Free State
- University of Johannesburg
- University of KwaZulu-Natal
- University of Kent

- University of Limpopo
- University of Mpumalanga
- University of Pretoria
- University of Utah
- University of Venda
- University of the Witwatersrand

The EWT and the IUCN – the International Union for Conservation of Nature

The EWT is a long-standing member of the International Union for Conservation of Nature (IUCN), the world's oldest and largest global environmental organisation comprising ~1,300 government and NGO members. During the year under review, the EWT's Head of Conservation, Dr Harriet Davies-Mostert, continued in her role as Chair of the IUCN South Africa National Committee, served as Chair of the Regional Committee for the East and Southern African Region, and represented the region on the Global Group for National and Regional Committee Development.

In addition, our expert staff play key roles among several of the IUCN's Commissions. Dr Ian Little is the Regional Chair for East and Southern Africa for the Commission on Ecosystem Management, and also represents the EWT on the Temperate Grasslands Specialist Group of the World Commission on Protected Areas. We are particularly active in the Species Survival Commission, with staff currently contributing to the following specialist groups and bodies under this commission:

- Afrotheria Specialist Group (Red List Coordinator)
- Amphibian Specialist Group (Facilitator, Habitat Protection Working Group)
- Canid Specialist Group (and its subsidiary, the Wild Dog Advisory Group)
- Cat Specialist Group (and its subsidiary, the African Lion Working Group)
- Conservation Planning Specialist Group
- Crane Specialist Group (co-Chair)
- Hornbill Specialist Group
- National Red List Alliance (member of the Coordinating Body)
- Stork, Ibis & Spoonbill Specialist Group
- Vulture Specialist Group (co-Chair)
- Lagomorph Specialist Group

Other participation

Vultures for Africa Programme Manager, André Botha, is the vice-Chair of the Technical Advisory Group of the Convention on Migratory Species' (CMS) Raptors MoU, is also a member of the Convention's Working Group on the Prevention of Wildlife Poisoning, and was recently invited to serve on its Lead Task Force.

Constant Hoogstad, Senior Manager: Industry Partnerships, is the Chair of the CMS Energy Task Force.



OUR SUPPORTERS

Strategic Partnerships

Department of Environmental Affairs
Eskom Holdings SOC Ltd
International Crane Foundation
Pathfinder International
Rainforest Trust
WESSA

Institutional Supporters

Cliffe Dekker Hofmeyr
Deloitte Southern Africa

Patron Supporters (R250,000 +)

African Parks
Avisense
Bakwena Platinum Corridor Concession
Barloworld Trust
BirdLife International
Bob Dohmen
Bridgestone South Africa
Cennerg
Charl van der Merwe Trust
Department of Environmental Affairs, Natural Resource Management
Elizabeth Wakeman Henderson Charitable Foundation
Eskom Holdings SOC Ltd
European Outdoor Conservation Association
European Union
Global Environment Facility – United Nations Development Programme
Hans Hoheisen Charitable Trust
Hawk Conservancy Trust
HCI Foundation
ICLEI – LAB:Wetlands SA
International Fund for Animal Welfare
Kathy and Tom Leiden
Leiden Conservation Foundation
Mary Dunea
Mohammed bin Zayed Species Conservation Fund
MyPlanet Rhino Fund
N3 Toll Concession (RF) Proprietary Limited
National Lottery Commission
Nimick Forbesway Foundation
Nissan Motor Company Ltd
Phumelela Gaming & Leisure
Rainforest Trust
Rand Merchant Bank /Tshikululu

Relate Trust
Roberts Family
Running Man Adventures
Fondation Segré
Signature Lux Hotels, by ONOMO
South 32
Stiftung Feuchebiete / Frankfurt Zoological Society
The Dohmen Family Fund
Tiger Brands
Tony and Lisette Lewis Foundation
Trans African Concessions
UK Department for Environment, Food and Rural Affairs
UK Illegal Wildlife Trade Challenge
UNDP Coca-Cola New World
United Nations Environment Programme
United States Fish and Wildlife Service
US Department of State, Bureau of International Narcotics and Law Enforcement Affairs (INL)
Whitley Fund for Nature
Windlab
WWF Nedbank Green Trust
WWF Zambia

Groundbreaker Supporters (R100,000 to R249,999)

Anglo American PLC
Assore Ltd
British High Commission
Caterpillar Foundation
CIB Insurance
Convention on the Conservation of Migratory Species of Wild Animals – Raptors MoU
De Beers Group of Companies
Department of Environmental Affairs, Biodiversity and Conservation
Gaie Fergusson
Global Environment Facility – Convention on the Conservation of Migratory Species of Wild Animals
GreenMatter – Mapula Award
Headley Trust
Investec
MySchool MyVillage MyPlanet
Nedbank
Neville Isdell
Pangolin Photo Safaris
Paul King
People's Trust for Endangered Species
Sharon Fischer and John Cannon
Stevens & Co (Pty) Ltd
The Resource Foundation



US Agency for International Development (facilitated by WWF South Africa)
Vodacom
Woolworths

Custodian Supporters (R50,000 to R99,999)

AHA Hotels & Lodges
Airlink – Rodger Foster
Allied Steelrode
Andy Baker
Badger Holdings
Bootleggers Liquor Store
Campo Marzio
Carter Cycad Foundation Trust
Conservation Action Trust
Craig Milner
Department of Environmental Affairs, Environmental Programmes
Eric Von Glehn
Europcar
Farmers AgriCare
Felix Schneier Foundation
G Adventures/Highline
Goldwagen
Hal and Merry Wissink
IQbusiness
Lex Henning
Livingstone Supply Co.
Marsha and Emmett Duemke
MECS Travel
Mones Michaels Trust
Nikegolf – Rohan Summers
Northern Cape Department of Environment and Nature Conservation
Painted Wolf Wines
Pick n Pay
Protea Hotels by Marriott® and African Pride Hotels
Raptors Botswana
Robert Hallam
Sere-med
Siemens
Thea Erasmus
Transnet
Trappers
UK Department for Environment, Food and Rural Affairs; Darwin Initiative
ZGAP – Zoologische Gesellschaft für Arten und Populationsschutz

Explorer Supporters (R2,500 to R49,999)

A Du Rand
African Bird Club
Afrif (Pty) Ltd
AJ van Ryneveld
Alastair and Laura Lamont
Alastair and Sheena Lamont
Ann Swann Personnel
Anne Rimbault
Anne Williams
Applus Steel Test
Arizona Center for Nature Conservation
Arno Netter
AV Oosthuizen
Avian Leisure
B Hackland
Barker Insurance Brokers
BE Stevens
Benjamin de Wet Cockram
BirdLife North Gauteng
BMW Bedfordview
Brian Atkins
Brothers Safaris
Buchanan & Payne Publishing
Canopy Tours
CG Campbell
Chris Brown
Christian Sutterman
Clicks Foundation
Craig Clucas
Crawford College Lonehill
Crofton Philip Reynolds
Darren Campbell
Dave Chapman
David Graaf Foundation
David Myers
Davies Foundation
Discovery
Dorian and Hilmar Wharton-Wood
Dorothy Barfoot
Douglas and Mary-Lynn Kydd
DS Botha
E Stassen
Econorisk
First National Bank
Flynn – Smart Noel
Fran De Jager
Fund for Animals



Funda Nenja
G Tait
Gary van Zyl
GCS – Water and Environmental Consultants
George W Mutch
Gina Lopes
Global Capital
Grant Morrison
Greg J Scorer
Group Partners Limited
Hatch
Helen McAlpine
Helen Struthers
Hlatikulu Conservancy
Hollard
Indwe Risk Services
IV Motor Investment t/a Bedfordview BMW
Jackie Keers
James and Debbie Blakemore
Jeremy Diviani
JH Goldberg
Joanne and Dennis Geiler
Joel Glenn
Johan van Jaarsveld
John B French
John Black
John Lamont
Jurgens Bekker Attorneys
Karen Van Rensberg
Kathleen D Ryan
Kelvin Legge
Ken Striker
Kintetsu World Express South Africa (KWE)
KLB Engineering
Kloof Conservancy
La Vita Living Products
Ladina and Dave King
Lakeside Nitro
Lankester White Safaris Ltd
Lauren Liebenberg
Lee Barnard
Legacy Lifestyle
Leigh Thackuray
Levego
Lifeform Taxidermy
Luke Callcott-Stevens
Mandy and Michael Oldham
Mark Drutman
Masterdrive – Defensive Driving
Meterman
Micromega
Millstream
Mr and Mrs Cherry
Mr and Mrs Frankel
Multiply Packaging
Munich RE
N Thomas

N&G Rentals
Nadostax (Pty) Ltd
Nando's
Natalie Sanders
NCT Forestry Cooperative Limited
ND Schnuir
Nell and Kevin Harris
Network for Animals
NFB Private Wealth Management
Nick Chapman
NTE Company
Oil Flow
Palladian House
Petclaims
PH Netscher
Philagro
Philip Moore Family Trust
Philip Reynolds
Philo De Villiers Trust
Phoenix Instruments
Platinum Life
Price Waterhouse Coopers
RAIN
Reichmanns
Richard Gundersen
RJ Joubert
Robert Hanssen
Robert Read
Roger and Vanessa Cockram
Roxy Kelly
RPP KZN Consulting Engineers (Pty) Ltd
Sally Blaine
Savannah Fine Chemicals (Pty) Ltd
Sean Ripley
Sean Williams
Selwyn Stoffberg
Shaun Schneier
Simbithi Eco Estate
Studio 88
Swiss Hotel School
Syntell (Pty) Ltd
Taddy McAllister
Tania Ihlenfeldt
TBA Tools
Thamesbridge
Thomas Hancock
Toine Knipping
Trans Africa Safaris
Ucomms
Undberg Bron Flemington
Verdun Pardini
ViaMedia
Wednesday Ladies Fellowship Group
William Kok
Winckler Platter Project
Zoological Society of Pittsburgh

In Kind Patron Supporters (R250,000 +)

Ad Outpost
Artifact Advertising
Esri South Africa
Ford Wildlife Foundation
Saving the Survivors
Zendai Property Development
In Kind Groundbreaker Supporters (R100 000 to R249 999)
CIB Insurance
Country Club Johannesburg (Auckland Park)
Eskom Holdings SOC Ltd
Kruger Mpumalanga International Airport
Land Rover Centurion
Microsoft Corporation
The Bateleurs

In Kind Custodian Supporters (R50,000 to R99,999)

Antony Wannell
Cathedral Peak Hotel
CopperTable
eThekweni Municipality
Ezemvelo KZN Wildlife
Floris Pelser
Fondation pour la Recherche sur la Biodiversité
I am Living Trust, Loxton
Jonsson Workwear (Pty) Ltd
Liverpool John Moores University
Martin Banner
Meltwater Media Monitoring
Nicolette van den Heever
Samantha de Villiers
Sharon Banner
Painted Wolf Wines

In Kind Explorer Supporters (R2,500 to R49,999)

ABI
Alucab
ANA Publishing
Bush Whisper Expeditions
Canopy Tours
Cell C
Champion Petfoods SA
City Lodge
Complete Cyclist
Copenhagen Zoo
Craighall Fruit Market
Cranefield Aviation
Cycle Lab
Die Rooi Granaat Loxton
Eastern Cape Parks and Tourism Agency
Elizabeth van Straaten
Eukanuba
Ezemvelo Honorary Officers – Vernon Crookes Nature Reserve
Fraser Gilchrist
Fruits & Roots

In Essence Skin Care – Rokeya Lakhi
Information Security Architects (ISA)
Infra Eco Network Europe (IENE)
IQbusiness
K9 Dispatch
Kaapjag
Karongwe Lodges
Kintetsu World Express South Africa (KWE)
Kloof Senior Primary School
Kruger Magazine
Ladies Fellowship Group
Legend Golf & Safari Resort
Little Green Beverages
Lovelee – Lee Middelton
Mark Lederle
Media Support Services
Michael and Elizabeth V Straaten
Mike Scholz
Mondelez International
MSD Animal Health
NAC
Nando's
NB Productions
Nespresso South Africa
North West Parks and Tourism Board – Pilanesberg National Park
Packleader
PaleoPet Pure
Paul Hutton
Richmark
Riverine Rabbit Retreat (Dunedin Farm)
Robert Abendanon
Royal Johannesburg & Kensington Golf Club
Sanbona Game Reserve
SANParks
Steve and Judy Joubert
Superga Footwear SA
Tenneco
Terreco
The Pro Shop
Thornybush Luxury Game Lodge Collection – Nic Griffin
Titleist
Toks Van Der Linde
Trappers
Verimark
Waterford Estate
Weber-Stephen Products (SA) (Pty) Ltd

Bequests

Late EL Murrell
Late JHM Yule
Late KBI Allen
Late M Halbekath
Late MM Hutton
Late NCG Hilterman
Late PRW Crawshaw
Late V Dohmeier

THE EWT'S BOARD AND TRUSTEES

Board of Management:

Dirk Ackerman (Chairman)	1999–current
Anthony Diepenbroek	2015–current
Antony Wannell	2005–current
Prof Barry Ackers	2017–current
Charlotte Lesego Rammusi	2017–current
Joanna Goeller	2006–current
Karin Ireton	2004–current
Lot Mlati	2007–current
Mike Esterhuysen	2001–current
Paul Smith (Treasurer)	2011–current
Sharmila Govind	2017–current
Uwe Putlitz (Vice Chair)	1987–current
Dr Veniela Pillay	2017–current
Yolan Friedmann (<i>ex-officio</i> member)	2005–current

Audit and Finance Committee (AFC):

Paul Smith (Treasurer: <i>ex-officio</i> member)	2011–current
Abdul Kader Mohamed	2016–current
Prof Barry Ackers	2010–current
Charlotte Lesego Rammusi	2017–current
Muhammad Seedat	2016–current
Neil Morris	2014–current

Social, Ethics And Remuneration Committee (SERC):

Mike Esterhuysen (Chair)	2010–current
Karin Ireton	2010–current
Paul Smith	2012–current
Sharmila Govind	2016–current
Dr Veniela Pillay	2017–current

Trustees:

Dirk Ackerman (Chairman)	1998–current
Uwe Putlitz	1980–current
Marilyn Dougall–Thomas	1993–current
Brian Courtenay	1996–current
Prof Robyn Stein	2001–current
Karin Ireton	2004–current
Antony Wannell	2005–current
Joanna Goeller	2006–current
Lot Mlati	2006–current
Rest Kanju	2008–current
Daniel van der Merwe	2010–current
Paul Smith	2010–current
Anthony Diepenbroek	2014–current
Christo Reeders	2014–current
Dr Crispian Olver	2014–current
Abdul Kader Mohamed	2015–current
Angela Cherrington (Oosthuizen)	2015–current
Anusha Lucen	2015–current
Prof Barry Ackers	2015–current
Charlotte Lesego Rammusi	2015–current
Kiyasha Thambi	2015–current
Sharmila Govind	2015–current
Sthembiso Dlamini	2015–current
Dr Veniela Pillay	2015–current
Muhammad Seedat	2017–current

Life Honorary Members:

Clive Walker	1986
Angeus Morrison	1993
Derek Ritchie	1993
Kenneth Whyte	1993
Dave Donald	2012
Michael Barnett	2013
Dr John Ledger	2013
David Mitchell	2013

CONTACT US

General enquiries:

Telephone: +27 87 0210 398
Fax: +27 (11) 6084682
Email: ewt@ewt.org.za
www.ewt.org.za

Postal Address:

The Endangered Wildlife Trust,
Private Bag X11,
Modderfontein, 1645,
Johannesburg, South Africa

Physical Address:

Building K2, Pinelands
Office Park, Ardeer Road,
Modderfontein, 1609,
Gauteng, South Africa

The EWT is registered as a Non-Profit Organisation, registration number 015-502 NPO and PBO Registration No 930 001 777. The EWT is 501 (c) (3) compliant, US IRS Reg. EMP98-0586801.

The EWT is a member of the International Union for Conservation of Nature and a signatory to the United Nations Global Compact.

Executive Management Committee



Yolán Friedmann
Chief Executive Officer
yolanf@ewt.org.za



Alison Jánicke
Head of Resource Development
alisonj@ewt.org.za



Dr Harriet Davies-Mostert
Head of Conservation
harrietd@ewt.org.za



Mandy Poole
Chief Operations Officer
mandyp@ewt.org.za

Senior Managers



Dr Ian Little
Senior Manager: Habitats
ianl@ewt.org.za



Constant Hoogstad
Senior Manager: Industry Partnerships
constanth@ewt.org.za



Kerry Morrison
ICF/EWT Senior Manager: Africa
kerrym@ewt.org.za

WHERE WE WORK

Locations in South Africa



Locations across Africa





General Enquiries:

[T] +27 87 021 0398
[F] +27 11 608 4682
[E] ewt@ewt.org.za

www.ewt.org.za



**ENDANGERED
WILDLIFE TRUST**
Protecting forever, together.