



Sustainable Development Report 2013

Green Development & Win-Win in Harmony

Sustainable Development Report 2013

Guangxi Yuchai Machinery Group Co., Ltd.

Yulin • China



Description of the YC Logo

The Group Logo "YC" is designed based on the acronym of the English name of the company. "YC" represents initials of Yuchai and Yulin China, demonstrating that Yuchai is firmly determined to build an internationally recognized Chinese brand. The letter "C" is like the earth movement trajectory in the space, symbolizing Yuchai Group's global development trend and that it is on the road of becoming a multinational conglomerate. The dynamic letter "Y" conveys the Group's strategic objective and pursuit of excellence.

The shape of the Logo is mature in shape, sober mixed with dynamic, plain but passionate. It incarnates that Yuchai is a group full of passion and is pursuing "Green Development & Win-Win in Harmony" as the domestic manufacturing base with the most comprehensive models of internal combustion engine and excavator products. The logo highlights Yuchai Group's global brand image of "Excellent Quality & Globalized Yuchai"

Yuchai philosophy



Profile of the report

Time range of the report

The report mainly covers Guangxi Yuchai Machinery Group Co., Ltd.'s activities in various areas of sustainable development in the period from January 1 to December 31, 2013, and if necessary, also covers related activities before the period.

Organizational scope of the report

The report has a focus on Yuchai Group's activities in various areas of sustainable development and at the same time presents information on its subsidiaries. For ease of presentation and reading, Guangxi Yuchai Machinery Group Co., Ltd. is hereinafter referred to as "Yuchai Group" or "Yuchai".

Release of the report

Since the release of its first sustainable development report in June 2008, Yuchai Group has published sustainable development reports for six consecutive years. The report is the seventh sustainable development report of Yuchai Group.

Basis of preparation of the report

Social responsibility disclosure based on the core themes determined in ISO26000 and related content.

Report data

The report is a true reflection of Yuchai Group's sustainable development activities. Information and data in the report all came from official documents and statistical reports of Yuchai Group as well as summaries of and statistics about sustainable development practices of affiliated companies. The financial data came from the 2013 financial report of Yuchai Group.

Way to obtain the report

For printed copies, please write to Guangxi Yuchai Machinery Group Co., Ltd.; for electronic copies, please download from Yuchai Group's website.

Report language

Chinese, English

Report form

Environmentally friendly paper, electronic document

Contact us

Office of Party Committee, Guangxi Yuchai Machinery Group Co., Ltd.
Address: No.1 Yuchai Avenue, Yulin, Guangxi, China
Zip code: 537005
Tel: 0775-3220651
Fax: 0775-3226887
E-mail: yuchaicsr@126.com
Website: <http://www.yuchai.com>

Report reliability guarantee

The company's board of directors and all the directors undertake that the report does not contain any false representations, misleading statements or material omissions and they are jointly and severally responsible for its truthfulness, accuracy and completeness.

Contents

Speech by the Chairman of the Board 6

01	Company profile	7
02	Organizational governance	10
	2.1 Incorporate new ideas into the governance model, be a responsible corporate citizen	11
	2.2 Strengthen audit supervision to ensure the health of the company	13
	2.3 Deepen culture development, foster a culture of accountability	15
03	Human rights responsibilities	18
	3.1 Help vulnerable groups, safeguard the basic rights of employees	19
	3.2 Show solicitude towards employees, safeguard the well-being of employees	20
04	Employee responsibilities	23
	4.1 Increase jobs, actively carry out job placement assistance	24
	4.2 Improve working conditions, establish a job grade-based compensation mechanism	24
	4.3 Carry out democratic management according to law, unblock channels for dialogue with employees	26
	4.4 Strengthen work safety to ensure the safety of employees	26
	4.5 Pay attention to employee education, offer a variety of development paths	27

05	Environmental responsibility	31
	5.1 Upgrade technology to effectively reduce emissions	32
	5.2 Treat "three wastes" to prevent pollution	35
	5.3 Energy conservation and consumption reduction, recycling	36
	5.4 Implement cleaner production to improve the environment	38
06	Operation responsibility	39
	6.1 Oppose corruption, advocate clean administration and protect the enterprise to maintain healthy operation	40
	6.2 Participate in politics and concerned more about the economic development of the state	42
	6.3 Run the business according to laws and resist unfair competition	43
	6.4 Implement lean supply and cooperate with cooperation partners to perform respective responsibilities	44
07	Responsibilities for customers	46
	7.1 Improve the quality and ensure that the products are safe and reliable	47
	7.2 Discover special potential and satisfy the requirements of different customers	49
	7.3 Be thoughtful of the users and provide them with professional VIP service	49
	7.4 Strengthen the training and enhance the service level	50
08	Community responsibility	52
	8.1 Charity activity, warm affection pervades the community	53
	8.2 Education donation, cultural communication	55
	8.3 Serve the residents and concern more about their health	57
	8.4 Social investment benefits the local region	57
09	Overlook of 2014	60
10	Appendix	62
	ISO26000 Index Contrast Form	62
	Form for feedback of Readers' Opinions	64

Speech by the Chairman of the Board

Yuchai is a living organism. Whether it can make its foundation everlasting depends on whether Yuchai's development is sustainable. So, we have been seeing improving and protecting the ecological environment of human beings and providing high-quality, high-performance and environmentally friendly and safe products for human beings as our responsibility and mission and will hold high the banner of green development and adhere to the path of green industrial development to lead the development of green power in China.

Today Yuchai has ushered in a new round of development and embarked on the "second phase of entrepreneurship" with a focus on "transformation and upgrading", including both industrial transformation and upgrading and the transformation and upgrading of systems and mechanisms and management, personnel, and work related to operations management, talent, culture, etc. Through the comprehensive transformation and upgrading, incorporate new ideas into the development model, enhance the core competitiveness of Yuchai and expand room for its survival and development and realize the sustainable development of Yuchai. The "second phase of entrepreneurship" embodies the connotation and true meaning of green development and a strategic deployment enabling Yuchai to make its foundation everlasting.

To implement the "second phase of entrepreneurship" and achieve transformation and upgrading, we must position ourselves clearly, plan scientifically and advance methodically. Bring new ideas to systems, improve management, integrate resources and optimize the structure culture-led, market-oriented, reform-driven, people-centered and project-based manner. Actively introduce and develop green industries, transform and upgrade existing traditional industries in a planned way and comprehensively improve the operating quality and operating efficiency of various industries to synchronize social and environmental benefits.

The "second phase of entrepreneurship" cannot be implemented and transformation and upgrading cannot be achieved without the support and active participation of



parties who have a common interest with Yuchai. Pool the wisdom and strength of many people to achieve success. We will mobilize more parties who have a common interest with us to participate in the "second phase of entrepreneurship" and be ready to listen to the advice and draw on the experience of parties who have a common interest with us to foster effective interactions. Bring in a fair and reasonable sound development mechanism and create a good development atmosphere and investment and construction environment for companies which are set to establish presence in Yuchai Industrial New Town to build a good and healthy green enterprise community.

Over the years, Yuchai has been working with all parties who have a common interest with us for mutual benefit, win-win and common development. "Green" gives us a common direction and common strength. On the journey of the "second phase of entrepreneurship", we expect parties who have a common interest with us to support and help Yuchai as they always did to create a better future.

Chairman of the Board of Guangxi Yuchai Machinery Group Co., Ltd.



Company profile

Company profile

Yuchai Group is a large modern enterprise group that primarily engages in a diversified range of industrial operations, has built six industry clusters of engines, energy & chemicals, logistics and automobile trade, spare parts, special purpose vehicles and construction machinery & equipments, has more than 30 wholly-owned subsidiaries, subsidiaries in which it holds a controlling interest and subsidiaries in which it holds a non-controlling interest and has 37.016 billion Yuan in assets and more than 20,000 employees.

In 2013, despite a slowdown in external macroeconomic development, a downturn in the industry market and other factors, Yuchai Group scored well on all business indicators by closely adhering to the "strong internal control, fine management, improved efficiency, steady growth" business policy to achieve steady improvement in the quality of business operations and promote the healthy development of industrial clusters of Yuchai Group. Yuchai Group achieved 42.466 billion yuan in sales revenues and sold 688,000 engines throughout the year. Guangxi Yuchai Machinery Company Limited sold more than 500,000 engines to become the first multi-cylinder diesel engine manufacturer in the industry to regain the sales level of 500,000 units, representing a year-over-year increase well above the industry average and delivering a 1% increase in its market share.

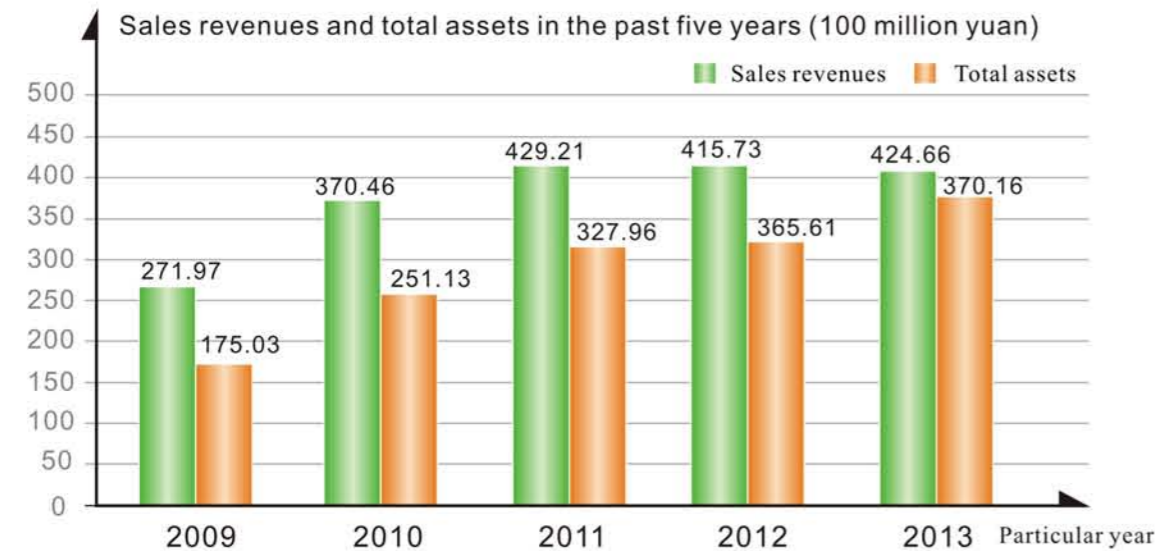

Sales Revenues of All Industry Clusters in 2013 (100 million yuan)

Industry clusters	Engines	Energy & chemicals	Logistics and automobile trade	Parts	Special purpose vehicles	Construction machinery
Sales revenue	227.62	115.85	30.10	36.89	4.85	9.35
Year-over-year increase	19.76%	-10.46%	-8.48%	4.89%	80.30%	-63.39%

Honors List 2013

Categories	Awards/Certificates	Award presenters/certificate issuers
General awards	One of The Top 500 Companies of China In 2013	China Enterprise Confederation, China Entrepreneurs Association
	One of The Top 500 Companies of China In Manufacturing In 2013	China Enterprise Confederation, China Entrepreneurs Association
	One of the Top 500 Companies of China in Machinery in 2013	China Machinery Enterprise Management Association
	One of the Top 10 Companies of Guangxi in 2013	Confederation of Guangxi's Enterprises and Employers
Brand awards	One of China's 500 Most Valuable Brands (10 th) 2013	World Brand Lab, World Executive Group
Technology awards	Independent Innovation Engine Award 2013	China Internal Combustion Engine Industry Association, China Automotive News co., Ltd.
	China Machinery Industry Science and Technology Award Second Prize	China Machinery Industry Federation, Chinese Mechanical Engineering Society
	China Machinery Industry Science and Technology Award Third Prize	China Machinery Industry Federation, Chinese Mechanical Engineering Society
	Tianjin Technology Invention Award First Prize	Tianjin Municipal People's Government
	Best Bus Engine Award	cnbuses.com, cv.ce.cn
	China Automotive Engine Pedigree 2013 Contribution Award	China Automotive Technology & Research Center
Management awards	Management Awards	China Quality nomination Award China Quality Awards Review and Recognition Committee
	Outstanding Organization in Terms of Corporate Culture Competitiveness on the 35 th Anniversary of Reform And Opening Up	China Research Institute of Enterprise Culture
	One of China's Top 100 Auto Parts Suppliers	China Automotive News Office
	An Outstanding Model for Innovation in the Tenth National High Quality Service Activity of The Agricultural Machinery Distribution Industry	China Agricultural Machinery Distribution Association
	A Model Company in the Region for Safety Culture Development	Administration of Work Safety of Guangxi Zhuang Autonomous Region
	Advanced Unit Named At The Ninth Enterprise Education Top 100 in China Annual Ceremony	Organizing Committee of Enterprise Education Top 100 in China
	Advanced Unit in National Mass Sports 2009-2012	State General Administration of Sports
	A Model Unit in National Community Overseas Chinese Affairs	Overseas Chinese Affairs Office of the State Council

Organizational governance measures

Yuchai Group has built a five-dimensional control system and a large audit system, revised and improved its control norms, subsidiary identity cards and business permission division tables, implements a property rights representative delegation system, a financial officer delegation system and has established rules for the management of the property rights representative's requests for instructions and the process whereby the property rights representative asks for instructions.

Yuchai Group has built Yuchai Group's "five-dimensional

matrix" indicator-based operating control system with "financial indicators, operational capacity indicators, profitability indicators, solvency indicators and human resource control indicators" to fully, dynamically and three-dimensionally monitor the operating quality of Yuchai Group; promote the iron triangle communication mechanism and the monthly operating control communication meeting mechanism rapidly respond to and deal with problems in the process of operating control.

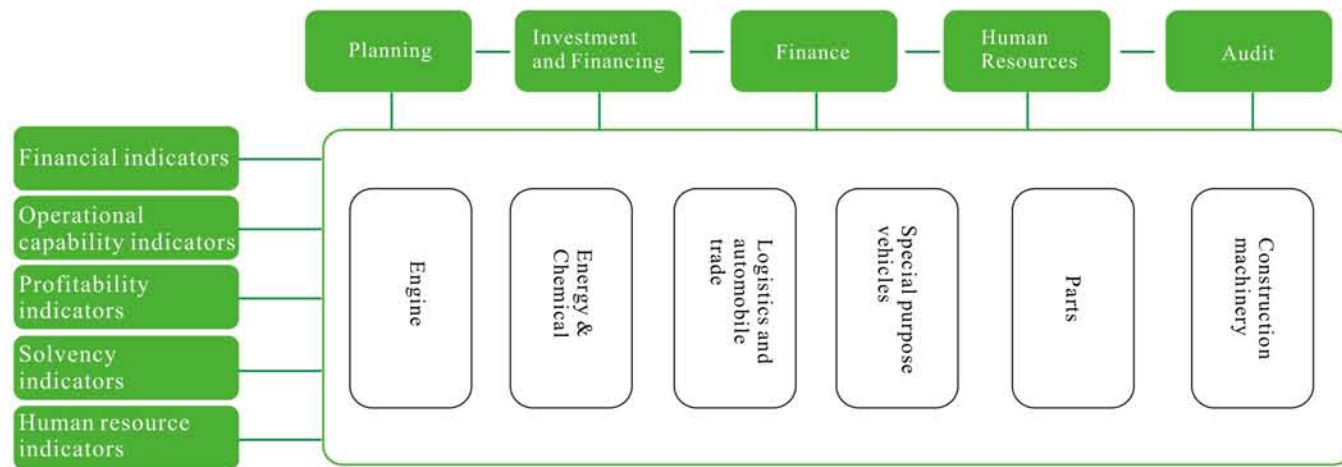

Five-Dimensional Control System Diagram

By creating a five-dimensional control system and risk management and control system, improving system processes, establishing an information and intelligence platform, rectifying

management problems and improving functions, ensure the timeliness and effectiveness of operating control for subsidiaries.



Total risk management structure

Conduct comprehensive risk identification and analysis and propose management recommendations in accordance with the "risk identification - risk analysis - risk assessment - risk response" thinking. Release the Risk Control System Construction Plan of Yuchai Group to specify the goals and principles of and the thinking behind building a risk control

system; develop the Comprehensive Risk Management System, establish a risk reporting mechanism and monitoring mechanism; combine risk management and operations management to improve cost control and financial management capabilities.

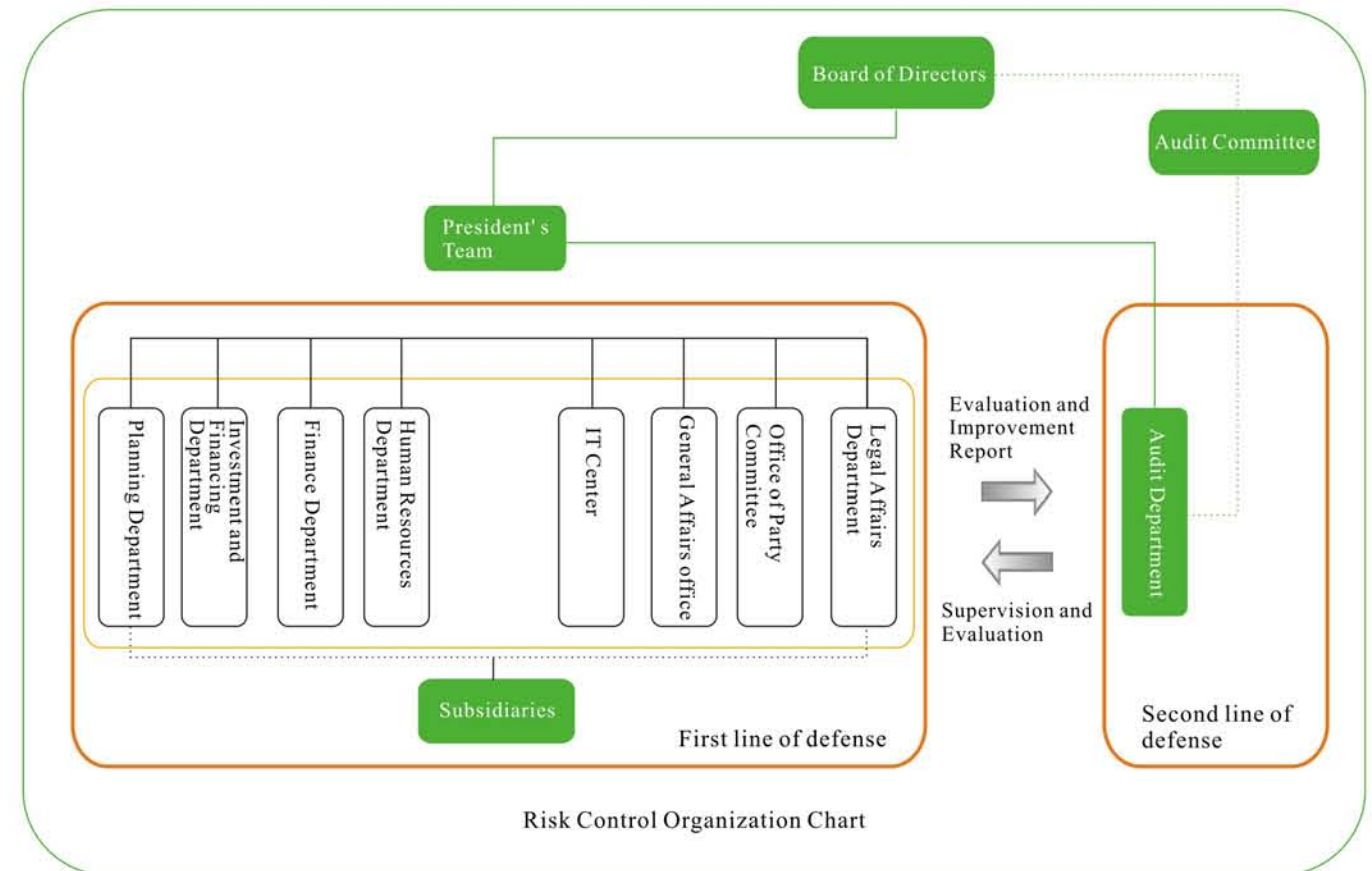

Risk Control Organization Chart

Note:

Solid lines in the figure represent administrative affiliations; dotted lines represent business management relations.

2.2 Strengthen audit supervision to ensure the health of the company

Yuchai Group has proposed the establishment of a "timeliness, normalization and whole process" large audit supervision mode and carries out and implements large audit work in accordance with "one goal, two-tier system, three constructions". Meanwhile, it has adopted a vertical

management mode and built a two-tier audit system for Yuchai Group and its subsidiaries to meet the audit supervision and service needs of Yuchai Group and its subsidiaries in internal control and ensure that the group can better fulfill its economic responsibility.

Internal Audit Value Model

According to the development direction of the construction of a system of enterprise internal control standards and internal audit, we have preliminarily established an internal audit value model.

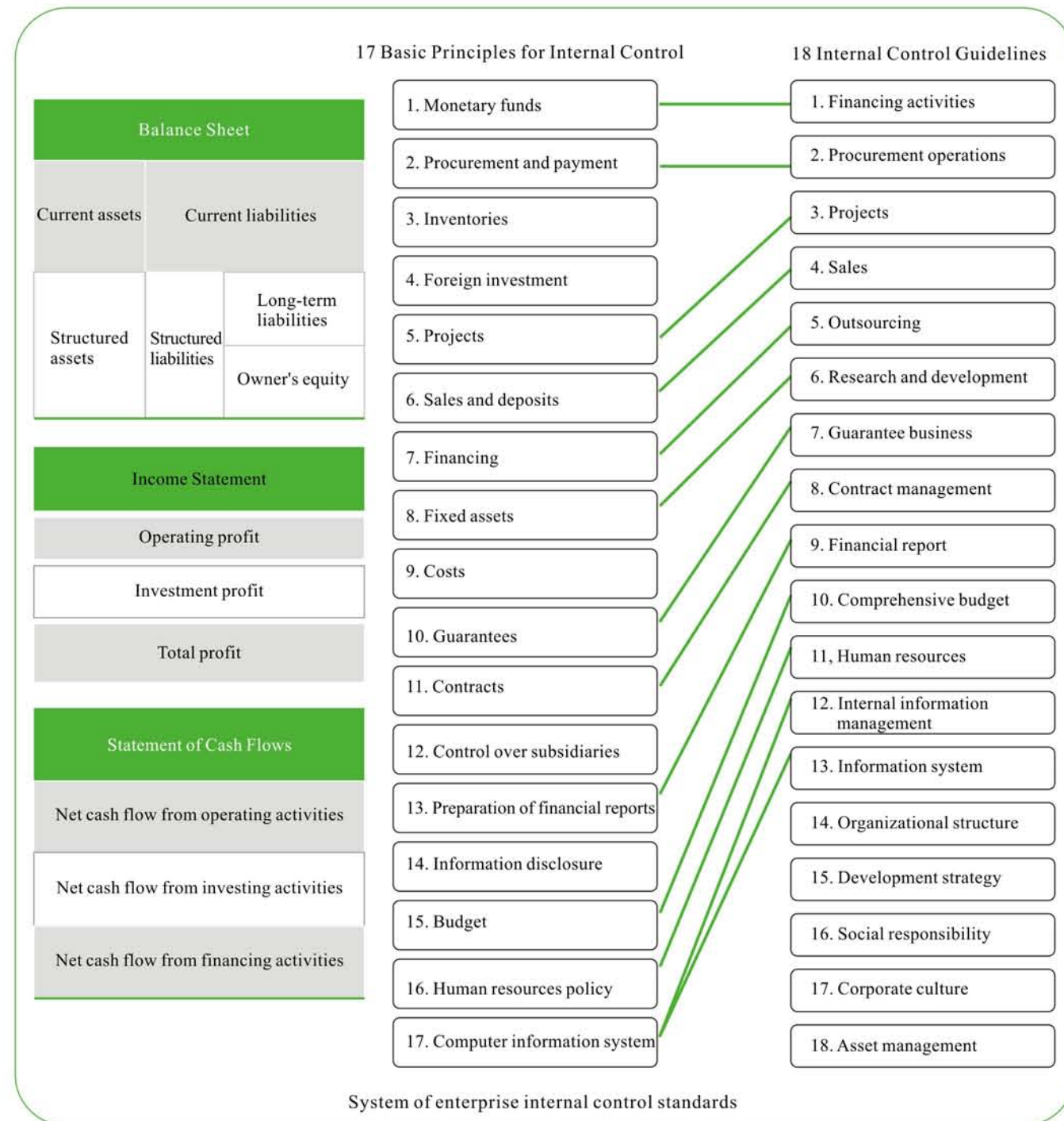

Internal audit results

We audited 13 subsidiaries, issued 13 audit reports and 1 research report and submitted a total of 404 audit findings last year. The number of audit report and audit findings submitted is on par with the number of submissions in the previous three years. Meanwhile, we recovered some economic losses for subsidiaries in the process of adjust amounts for audit reports and disclosing non-performing assets. Our findings and recommendations in internal control management have been approved by subsidiaries; we will make further improvements to audit systems and practices; we will constantly upgrade and improve the quality of audit services and are committed to improving internal control, operations management and risk prevention for subsidiaries to create value for shareholders.

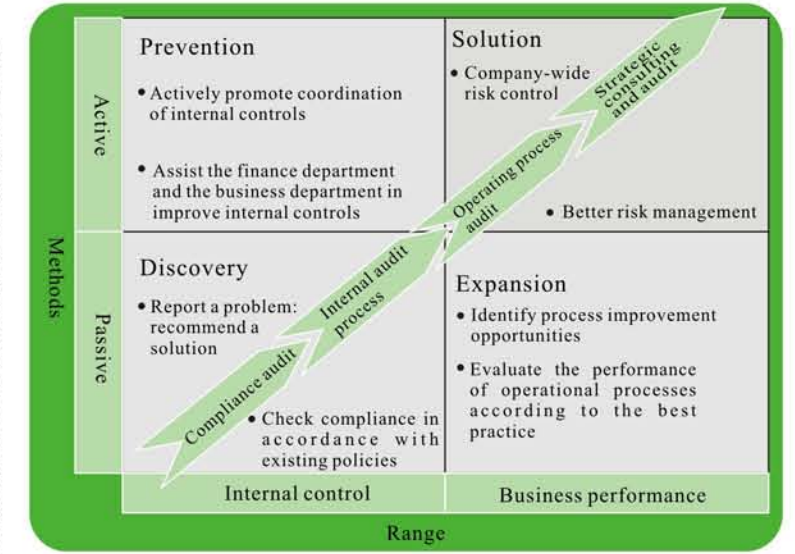

2.3 Deepen culture development, foster a culture of accountability

Yuchai Group focuses on safety culture, quality culture, excellent team culture and other functional sub-culture development and cultural extension work to create a good

culture, enhance employees' cultural awareness and improve the group's ability to fulfill its social responsibility.

Safety culture development



In recent years Yuchai Group has incorporated occupational safety concepts and occupational and environmental policies into systems and processes to regulate work safety management and employees' safety behaviors through the implementation of an occupational health and safety management system, an environmental management system and a work safety assurance system. Strengthen safety awareness training for employees. We have conducted national "Work Safety Month", "Ankang Cup", "Work Safety Team", "Hazard Investigation" and other competitions and a series of activities such as "119" fire protection and traffic safety speech contests to guide all employees towards participation in safety culture development. Increase investment in work safety rectification and labor protection funds and improve hardware facilities for safety culture development. We have developed and implemented specific safety plans and measures to create a strong safety culture. Guangxi Yuchai Machinery Co., Ltd. has been awarded the title of "A model company in the region for safety culture development" by the Administration of Work Safety of Guangxi Zhuang Autonomous Region.

Extension of corporate culture

Yuchai Group has created a Q3 culture characteristic of its procurement system by summarizing and refining practices and experiences in supplier quality management, and pass them to

and let them permeate supply chain management through advocacy and communication, quality education, etc.

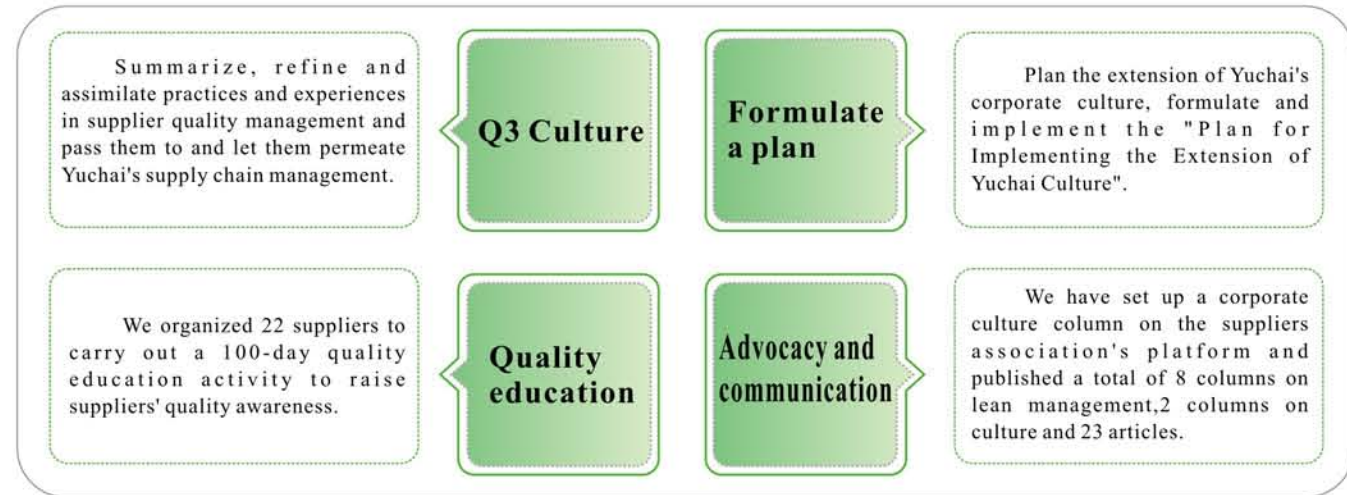

Bring quality culture to workplace

Yuchai Group has held two promotional activities intended to bring quality culture into workplace. The activities were themed around disseminating corporate culture and quality culture and aimed to reinforce the mass base of quality work and strengthen the quality awareness of all employees. Quality management personnel from various units of the group joined the activities.



Corporate culture activities

Yuchai Group spreads Yuchai cultural ideas, strengthens the cultural awareness of grassroots employees, increases employees' cultural identification and promotes organizational cohesion by holding corporate culture knowledge contests,

corporate culture on-site experience exchanges and seminars, corporate culture development results release and reading forums, activities intended to bring lectures on ethics into the plant and other corporate culture activities.



On May 10, Yuchai Group held a corporate culture on-site experience exchange and seminar in Beihai, Guangxi to share experiences in corporate culture development, explore in-depth cultural integration between subsidiaries of different nature in different places, culture development and implementation for subsidiaries, spread and implementation of the concept of functional culture and other related issues.



Human rights responsibilities

- 3.1 Help vulnerable groups, safeguard the basic rights of employees
- 3.2 Show solicitude towards employees, safeguard the well-being of employees

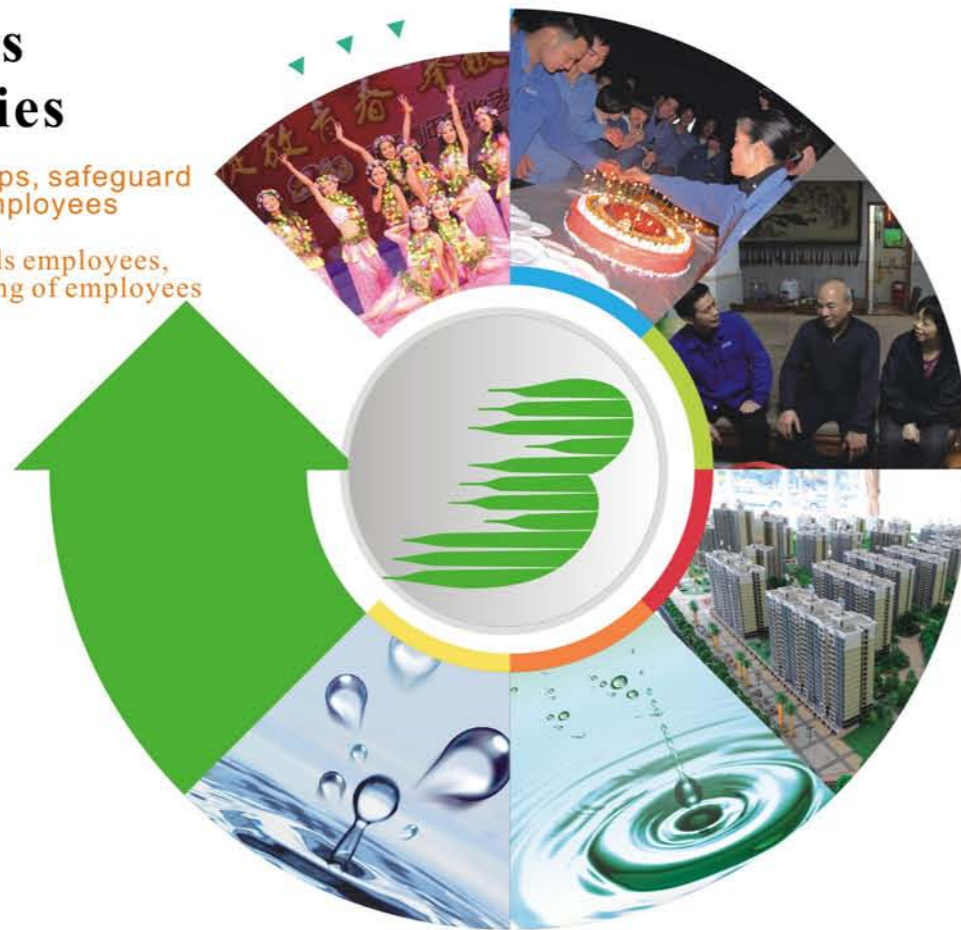

3.1 Help vulnerable groups, safeguard the basic rights of employees

Yuchai Group respects and safeguards the basic labor rights of employees, strives to eliminate all forms of forced labor, prohibits child labor, strives to eliminate employment discrimination and job discrimination, actively safeguards the economic, social and cultural rights of employees.

Total Number and Composition of Employees 2013

Total number of employees	Female		Ethnic minorities	
	Number of people	Proportion	Number of people	Proportion
20,083	4,408	21.95%	1,694	8.43%

Help vulnerable groups

Yuchai Group actively helps vulnerable groups, fulfills its corporate social responsibility in respect of the employment of people with disabilities, had 36 people with disabilities on its payroll in 2013 and pays money into the employment security fund for the disabled each year in accordance with relevant regulations of the state.

Provide further safeguards for employees

According to national and local policies, Yuchai Group provides pension, medical, unemployment, workplace injury and maternity insurance and pays housing provident fund contributions for all employees on payroll, provides critical illness insurance, mutual insurance, personal accident insurance and other supplementary insurance for employees, offers regular health examinations for employees and conscientiously implements its paid annual leave system.

Yuchai Group provides economic aid, health examination, old-age insurance benefits eligibility verification, application for medical insurance coverage of outpatient treatment of special chronic diseases and other services for retired employees and provides safeguards for financially strapped employees in terms of aid and treatment of critical illnesses.

Enrich employees' recreational and sports activities

Yuchai Group organizes and carries out all kinds of artistic performances and sports competitions, such as national fitness activities, youth culture and art festival, culture and art festival for the elderly to achieve the goal of "having activities every

week and competitions every month". A total of more than 7,000 people participate in various recreational and sports activities.

Youth Culture and Art Festival

Tug of war

Fun sports competitions

"July 1" poetry recitation party

Basketball match

Balloon volleyball match

3.2 Show solicitude towards employees, safeguard the well-being of employees

Yuchai actively helps and offers consolation to employees and has launched an affordable price commercial housing project to solve housing problems for employees and effectively

assists relevant departments to improve the surrounding living environment.

Offer consolation and assistance to employees

In 2013, the person-times of employees to whom Yuchai Group offered affection and consolation grew 18.49% from a year earlier with the amount of consolation money reaching 198,000 yuan, provided assistance worth 46,121.76 yuan to

employees who experienced economic difficulties as a result of critical illnesses, natural disasters, etc. and distributed 297,100 yuan worth of birthday cakes to employees.

Company leaders offer consolation to financially strapped employees

An employee's birthday party held at the production line

Care for Employees (unit: person-times)

No.	Category	2012	2013	Year-over-year
1	Consolation to employees and their families	4,389	4,704	7.18%
2	Consolation to hospitalized employees	6,254	6,518	4.22%
3	Home visits	3,088	4,661	50.94%
4	Birthday celebration activities	21,762	27,128	24.66%
5	Affection	435	522	20.00%
6	Allowances for its neediest employees	258	859	232.95%
	Total	36,186	44,392	18.49%

Launch an affordable housing project

Yuchai Group has launched an affordable price commercial housing project. The total area of affordable housing reaches 16,0817.67 square meters. It plans to build a housing estate with a total floor area of 620,000 square meters, which is expected to

provide 5,069 housing units for employees and will be built in three phases, 1,879 units in the first phase, 1,038 units in the second phase and 2,152 units in the third phase.



Affordable housing plan

Prior to March, the coal yard of Yulin Railway Station was adjacent to Yuchai Group and dust produced by it seriously polluted the surrounding environment, affecting employees' work and life. Yuchai Group strived to cause and assist relevant departments to relocate the coal yard. On March 21, through the joint efforts of all parties, coal yard was smoothly relocated.

A truck carries the remaining coal in the coal yard away

Employee responsibilities

- 4.1 Increase jobs, actively carry out job placement assistance
- 4.2 Improve working conditions, establish a job grade-based compensation mechanism
- 4.3 Carry out democratic management according to law, unblock channels for dialogue with employees
- 4.4 Strengthen work safety to ensure the safety of employees
- 4.5 Pay attention to employee education, offer a variety of development paths



4.1 Increase jobs, actively provide job placements

Yuchai Group strictly abides by national laws and regulations, actively increases jobs and provides job placements. It hires 1,412 new employees each year and

employs 22,529 people each year on average. It signs labor contracts with all of its employees and provides equal pay to men and women for equal work.

Yuchai Group spares no effort to support subsidiaries which experience temporary operational difficulties, works with them in staff optimization, diversion and placement and implements internal transfers and job placements so as not to add to society's burden of providing employment. It diverted and

provided placements to 108 employees throughout the year and implemented the placement policy for children of employees of Yuchai Group to provide placements to 21 children of its employees.

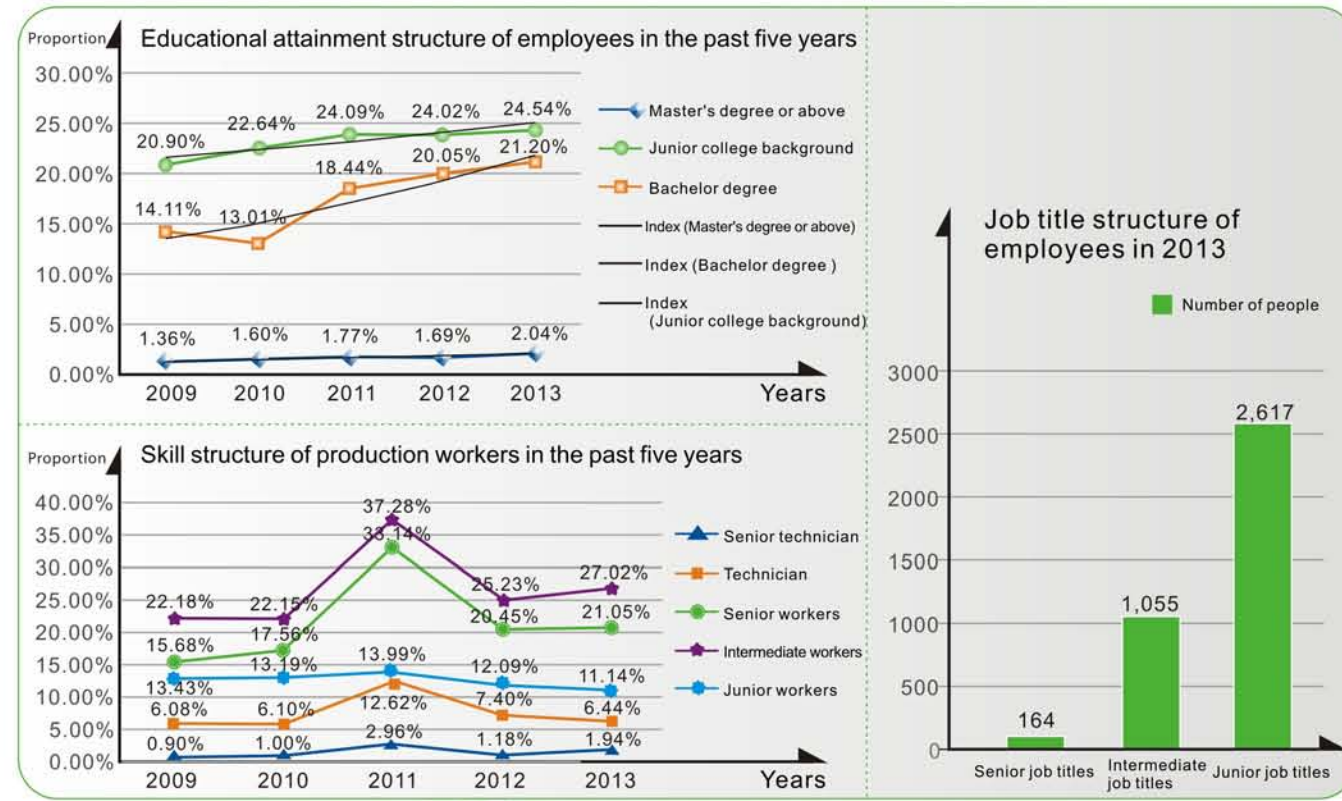

Facing a construction machinery market which remained extremely sluggish in 2013, Guangxi Yuchai Heavy Industry Co., Ltd. as the group's subsidiary actively coped with difficulties and challenges by streamlining organizations and optimizing and diverting staff. The process was open and transparent, employee representatives participated in the whole process and not a single employee complaint occurred. It used a method that combined hiring and competing for jobs to place personnel whose comprehensive quality was relatively high and whose ability and quality meet the needs of relevant positions in these positions. The number of organizations was reduced from 215 to 67 and the number of managerial cadres from 337 to 105. Yuchai Group coordinated with its subsidiaries to divert and provide placements to personnel who failed to be chosen or allow them to compete for jobs again after being trained for new jobs.

4.2 Improve working conditions, establish a job grade-based compensation mechanism

Yuchai actively improves employees' working conditions, allocates salary in a scientific and reasonable manner and uses the performance-linked pay method, post wage appraisal and determination method, average wage per capita appraisal and determination method, method based on determining the amount of profit made in an turnaround, guidance wage levels

reference method, management by objectives method and other total wage appraisal and determination methods in an integrated manner to safeguard employees' salary income more scientifically and effectively and allow the company and its employees to develop together.

Improve employees' working conditions

Through the implementation of a lean production mode and the extensive application of principles of ergonomics, Yuchai

has effectively improved the working environment and working conditions to reduce the labor intensity of employees.

Engine Plant 1 of Guangxi Yuchai Machinery Co., Ltd. has successfully managed to turn the crankshaft for such technological equipment as valve of heavy-duty engines and vehicle engines, which substitutes the manual turning of crankshaft by workers, avoids the bending of employees and effectively reduces the occurrence of such occupational disease as Prolapse of Lumbar Intervertebral Disc. The Plant has also increased more turntables for preassembly line of the heavy machine to be tested, so that the hidden danger of workers working across the roller table is avoided.

Manually adjust the valve clearance

Adjust the valve clearance using crankshaft for holding chuck of servo motor

Establish a job grade-based compensation mechanism

Yuchai implements grade-based salary matching employees' career grades to linked employees income to their ability and contributions.

grade is determined according to professional skills and job performance and the compensation grade is determined according to the qualification grade. In addition to considering the value of jobs, we also consider employees' competence, job performance and other dimensions, which is more conducive to improving employees' professional competencies.

Job grade-based compensation is determined by the "job sequence + qualification grade" combination. The value of a job is determined according to the job sequence and the qualification

Implement effective incentives

Yuchai implements annual performance incentives, rewards for projects, rewards derived from profits generated by new products and rewards for minor changes and reforms and reasonable suggestions and has set up incentive funds,

outstanding contribution awards, major scientific and technological progress awards and other incentive programs for top-notch talent.

In 2013, Guangxi Yuchai Machinery Co., Ltd. became the first to achieve the excellent result of selling more than 500,000 multi-cylinder engines in the industry. 7 managerial personnel including Wang Limin, Huang Weishu, Zhou Chuanwu, Lin Zhijiang, Chen Ningbin, Chen Long and Zhong Yunhui were amply rewarded by the company for their outstanding performance, each receiving a car worth 220,000 yuan.

4.3 Carry out democratic management according to law, unblock channels for dialogue with employees

Yuchai Group carries out democratic management strictly in accordance with the law and unblocks channels for employees' participation in management through congress of workers and staff, informal meetings with employees, general manager mailbox, rationalization, employees' proposals, collective contract negotiations, etc.

It inspected the performance of the Collective Contract and the Special Collective Contract for Women Workers twice and hold consultations over inspection of the performance of the Collective Contract and the Special Collective Contract for

Women Workers twice throughout the year.

It organized the team of employee representatives to discuss the Regulations on the Management of Labor Contracts and sought opinions on continuing the implementation of the working system based on comprehensive computation of hours worked. The team of employee representatives reviewed the forthcoming Regulations on Rewards and Punishments for Employees to safeguard the legitimate rights and interests of employees.

On March 23, Yuchai Group held the second meeting of the seventeenth congress of workers and 735 employee representatives 15 nonvoting delegates from various units attended the meeting. Employees representatives heard and passed the work report and budget and final account report by the president's team of Guangxi Yuchai Machinery Group Co., Ltd. and the work report and budget and final account report by the general manager's team of Guangxi Yuchai Machinery Co., Ltd., reviewed and discussed the congress of workers and staff's report democratic appraisal of leaders, report on the performance collective contracts, report on the implementation of proposals made at the last meeting of the congress of workers and staff and report on the solicitation of proposals for the meeting.



4.4 Strengthen work safety to ensure the safety of employees

Pass national work safety standardization level 1 certification for machinery manufacturers

In order to improve work safety management, strictly implement national work safety regulations and standards and make Yuchai's safety management more standardized, scientific and systematic, Guangxi Yuchai Machinery Co., Ltd., with a focus on national work safety standardization certification for machinery manufacturers, has set goals and indicators for the control of environmental factors/hazard targets, revised and improved 22 occupational health and safety management system documents, established the *Comprehensive Safety and Environmental Emergency Plan*, the *Emergency Plan for Hazardous Waste Accidents* and emergency plans for environmental accidents and formulated emergency measures

Strengthen safety awareness training and rectification of safety problems

Yuchai Group pays special attention to routine safety training and special safety training and carries out work safety month activities. It carried out a special inspection for safety evaluation purposes and found 906 problems; completed 834 rectification tasks within the year. It reviewed 367 "three simultaneous" projects; it monitors external entities that undertake construction for safety problems all the way and makes rigorous safety checks; it takes a hierarchical approach to management and promotes KYT to greatly improve safety, environmental and site management.

for the discharge of wastewater that has higher-than-allowed pollutant concentrations, chemical spills, fires caused by hazardous waste, leaks, etc. In December, the company was certified as a first grade enterprise in national work safety standardization with a score of 95.5 points.

Fulfillment of Work Safety Targets in 2013

Target	Desired value	Completion	Remarks
Fatalities	0	0	
Major equipment accidents, major fire accidents	0	0	
Serious injury accident rate	≤0.03%	0	
Minor injury accident rate	≤3%	0.12%	
On-site safety hazards rectification rate	100%	100%	
Discharge of "three waste" (waste gas, waste water, waste residue)	Not go beyond the limits	Meet the standard	
Occupational disease prevention and control rate	100%	100%	Workers performing jobs that involve toxic and hazardous substances undergo comprehensive health examinations

Strengthen road safety awareness

In Engine Plant 2 safety management, strengthening road safety awareness occupies an important position. The plant strengthens road safety awareness of employees through a variety of safety management methods such as weekly safety commitments, non-scheduled supervision and inspection of employees' wearing of helmets on their way to and from work and road safety seminars to safeguard the safety of employees.

4.5 Pay attention to employee education, offer a variety of development paths

Yuchai Group attaches importance to employee education and has been continuously improving its personnel training system to provide a wide range of training and practice opportunities for employees. It actively expands the platform for employees to become talented persons and grow and offer a

variety of development paths for employees through career planning, selection of middle-level managers through open competitions, the implementation of a skills master studio mechanism, etc.

Attach importance to employee training

Yuchai Group has invested over 8.5 million yuan in training. The employee training coverage is 100% and the average number of training hours per employee is 108, including

safety training, new employee training, special training, skills training, training for special types of work, external training, academic education and training, etc.

Employee Training in the Past Five Years

Year	Training periods	Training person-times	Total training hours
2009	1,668	154,211	755,055
2010	1,899	218,055	760,523
2011	1,934	262,083	1,212,417
2012	2,017	202,457	952,851
2013	2,909	217,173	1,085,837

Yuchai personnel training system

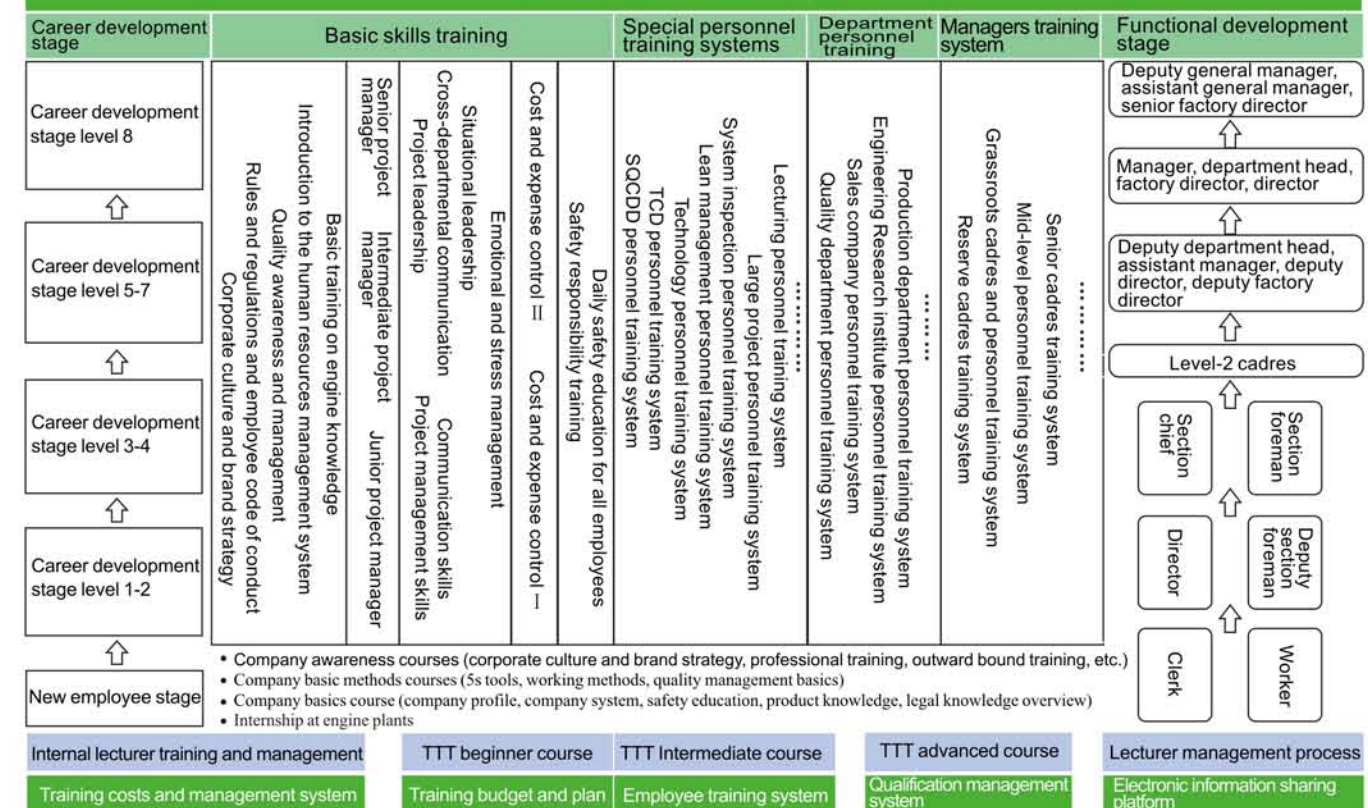

Set up skills master studios and the model workers innovation studio

Yuchai Group has set up skills master studios for the six types of work of fitter, internal combustion engine commissioning & repair, machining, welding and electrical maintenance and the model worker innovation studio.

The skills master studios are jointly managed by the training center and the technicians association, make work plans and set work objectives annually and have established relevant performance evaluation systems. According to their plans and objectives, the skills master studios organize skills masters to carry out a series of work.

Since its inception, the studio has complete 19 projects involving tackling challenging problems and 29 master-apprentice programs, set up 20 training classes, offered skills training 173 times and carried out 6 new technology research projects. A number of projects involving tackling challenging technical and quality problems including "method for automated casting of complex diesel engine bodies", "large diesel engine iron-wood-plastic hybrid tooling technology innovation and industrialization" have won national and regional-level awards.

Yuchai's model worker innovation studio has passed the acceptance inspection by the Yulin Municipal Federation of Trade Unions. Yuchai's National fitter skills master studio has been approved by the Ministry of Human Resources and Social Security and received 100,000 yuan in construction funds.



Make a career plan for employees

Yuchai Group divided career paths into the administrative path, specialties path and skills path along the dimensions of administration, specialties and skills and subdivided them into 18 sequences and 41 sub-sequences. Employees may choose vertical or cross-path development according to their own strengths. Yuchai Group determines the appropriate career path

level for employees according to the results of employees' annual performance and capability assessment and provides a variety of employee development paths including open recruitment for jobs within Yuchai Group, competition for managerial positions and recommendation of candidates for administrative assistants.

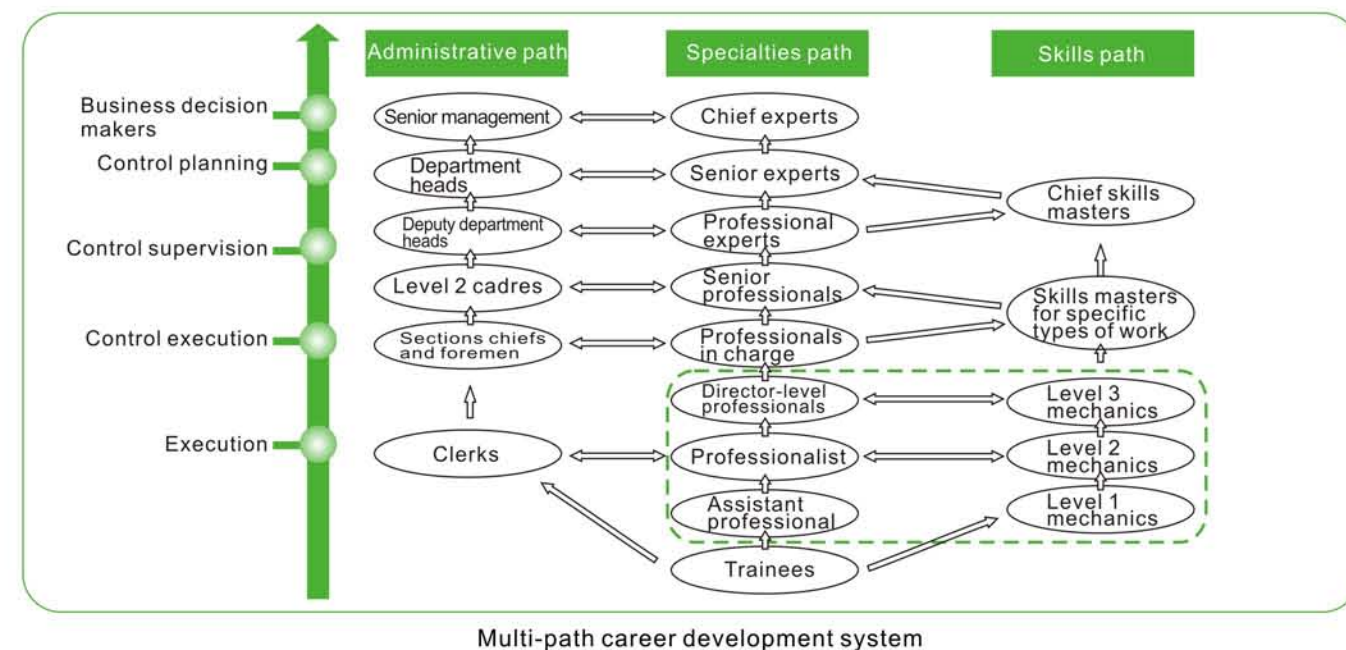

Position group	Management	Technical	Marketing	Specialty	Production
Position	Business management Operation management	Research and development	Marketing	Quality Purchasing Equipment upgrading	Operation Technique Production Legal affairs
Position sub-series	Management and operation Strategic planning Party-masses-labor union management	Product planning Design development Testing and development Comprehensive business	Market Technical service engineering Field process design Process management Application technology management Equipment development Electrical control development	Quality inspection Purchasing Technical reform Safety and environmental protection Kinetic energy of equipment Equipment maintenance	Customer service Driver Supporting service Operation Production management Legal affairs IT
Career pathway	Pathway of specialized technology				Pathway of technique

Career path

On October 22, Guangxi Yuchai Machinery Co., Ltd. began to select middle-level reserve cadres from grassroots. Section-level managerial cadres who have worked in the production line, marketing line or technical line for more than two years, hold a bachelor's degree and under the age of 35 or hold a master's degree and under the age of 38, have more than 5 years' working experience and served in a position for more than one year may participate in open selection.





Yuchai Group conscientiously implements the high-level talent incentive policies of the State, Guangxi, Zhuang Autonomous Region, Yulin City and Yuchai Group and the Small Talent Highland has received 1.3 million yuan in earmarks from the district government. Yan Ping was awarded the title of "Outstanding Expert of Guangxi Zhuang Autonomous Region"; Shen Jie, Feng Jing among others were hired as one of the second batch of Bagui scholars and distinguished experts of Guangxi Zhuang Autonomous Region; Lin Zhiqiang is included in the list of the sixteenth batch of second-level candidates for the "New Century Hundred-Thousand-Ten Thousand Talent Project"; Feng Jing and Chi Zhaojiu receive the State Council special allowance.



Yan Ping

Shen Jie

Lin Zhiqiang

Feng Jing

Chi Zhaojiu

Environmental responsibility

- 5.1 Upgrade technology to effectively reduce emissions
- 5.2 Treat "three wastes" to prevent pollution
- 5.3 Energy conservation and consumption reduction, recycling
- 5.4 Implement cleaner production to improve the environment



5.1 Upgrade technology to effectively reduce emissions

Yuchai Group increases spending on research and development every year, has been following international cutting-edge engine technology closely, has built three technology platforms and accumulated five technical advantages, has been continuously developing green power and has brought along a comprehensive upgrade of its product

technology by upgrading its emission standards, not only improving the power performance, economical efficiency, reliability and environmental friendliness of its products, but also enabling it to meet the requirements of national emission regulations and standards 2-7years ahead of schedule.

Increase investment in research and development to boost research and development capabilities

Yuchai's enterprise technology center ranks 20th among 887 state-certified enterprise technology centers in the country,

up 16 spots over 2011, continues to rank first in the engine industry and has received the title of "outstanding unit".

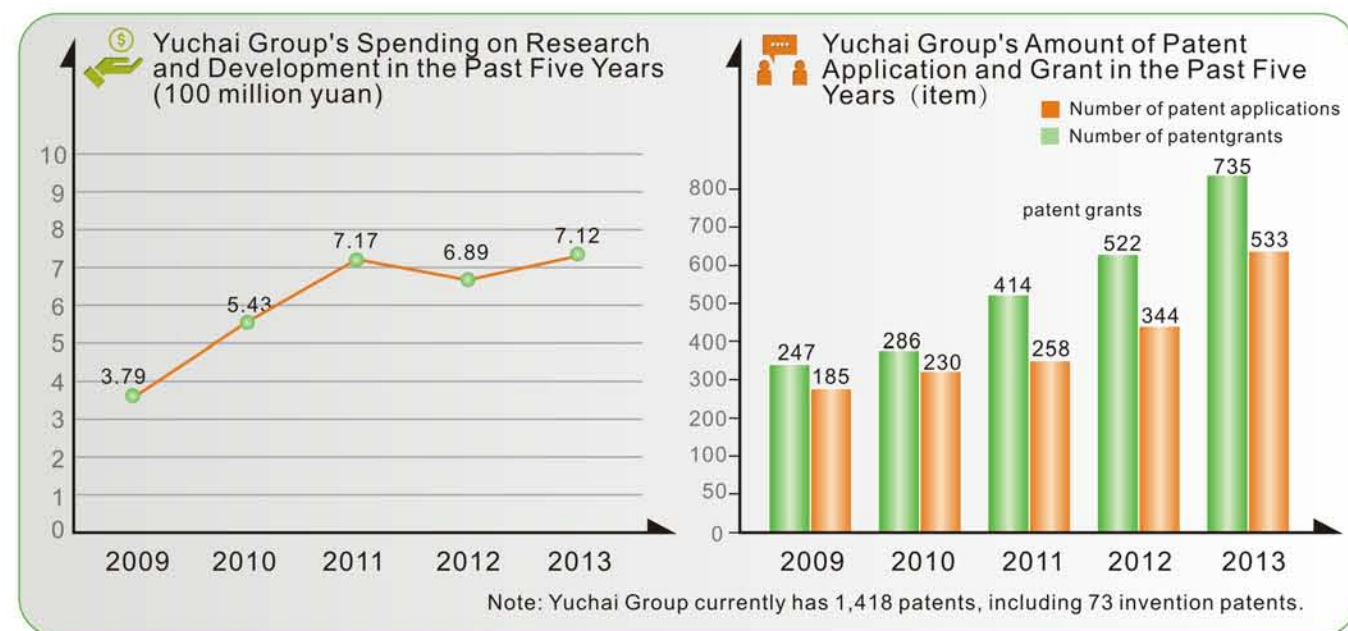

Build technology platforms and technical advantages

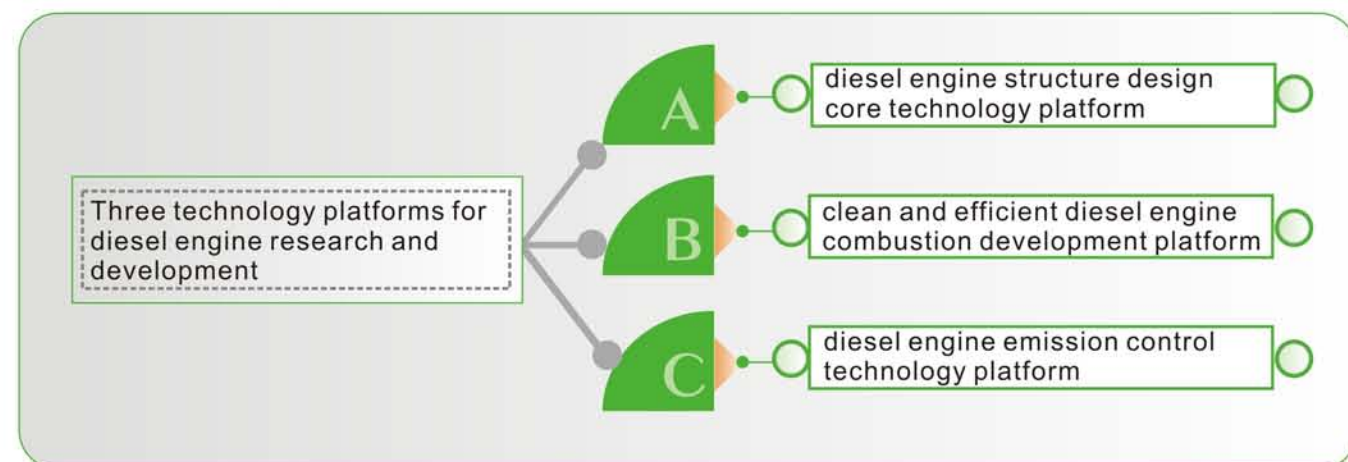

Five technical advantages of its engine products

A

Application-based combustion control and calibration technology

Meet the special requirements of different market segments through the collection of data on typical operating conditions, the collection of data on typical load spectra, combustion development for performance, control strategies based on simulation results and user-oriented calibration of electronic control units and with market demand-oriented differentiated products.

B

Compression release engine brake

Yuchai's unique compression release engine brake technology delivers a 55% increase in the braking force on the vehicle and provides over 10% more braking force than similar products of Europe and the United States; reduces and even eliminates the need to step on the brake when traveling down a long slope to effectively prevent braking force attenuation, brake failures and skids on rainy days; reduce wear of the master brake system, reduces tire wear, can save an average of 4000 yuan a year in running costs, improves the speed when going downhill, increases transportation efficiency; provides high braking power at low speeds and can reduce shift frequency when traveling downhill.

C

Gas engine control system ESI technology independently developed by Yuchai

The electronically controlled single-point injection gas engine control system independently developed by Yuchai uses the electronically controlled single-point injection mainstream technology that is in line with international standards, provides precise control, is energy efficient and environmentally friendly, has automatic diagnosis and powerful vehicle control functions and meets the needs of different customers.

D

Intelligent fuel-saving switch

An electronic intelligent fuel-saving system based on different loads. The driver can choose a multi-state switch according to the vehicle load to effectively reduce fuel consumption. Fuel consumption reduction $\geq 6\%$.

E

Intelligent remote management system

Build an interactive communications platform for persons (drivers), machines (engine and vehicle) and control unit (platform management system) based on modern electronically controlled engine technology and modern communication and network technology and through Yineng vehicle-mounted intelligent controller and platform intelligent management system to provide real-time engine and vehicle operation services and operations management services for users.

Develop eco-friendly products

Yuchai adheres to green and sustainable development as its direction, constantly optimizes its product mix and layout, has launched 5 series diesel engines that meet the Euro IV Emission Standard and 7 series gas engines that meet the Euro V Emission Standard and accomplishes in-engine purification mainly

through the two measures of "optimizing the fuel chamber and improving combustion to reduce harmful gases produced" and "reducing fuel consumption to reduce particles" to achieve the goal of emission optimization.

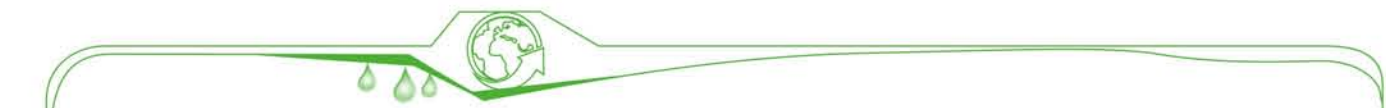

YC6MK series diesel engine won the Best Bus Parts Award 2013

From May 22 to 24, a total of 7 environmentally friendly engines of Yuchai including 2 large upgraded bus power systems that meet Euro IV Emission Standard (YC6MK and YC6L), 2 gas engines that meet the Euro V Emission Standard (YC6MKN and YC6LN), one power system for school buses (YC6J), 1 2nd generation hybrid power system and the 3.8 liter YC4S engine which was launched in 2013 and has a target market of mainly mid-high end cars for business reception took part in the "Beijing International Road Transport and Urban Public Transport Vehicles and Parts Exhibition 2013". YC6MK-40 engine with its excellent power performance, energy efficiency and reliability won the "China Road Transport Cup" Best Bus Parts Award 2013.



YC6MK series diesel engine

A gas engine that meets the Euro V Emission Standard and the Euro VI Emission Standard

Yuchai already started gas engine research and development as early as 16 years ago. It has been undertaking the "development of CNG engine products for large buses" project, an important project under the 863 Program and is well ahead of other Chinese companies in the same line of business in terms of technical sophistication and applicability. The seven series gas engines YC4DN, YC4GN, YC6JN, YC6LN, YC6GN, 6MKN and YC6KN deliver power ranging from 120PS-440PS, meet Euro V Emission Standard and Euro VI Emission Standard, cover all buses application and can satisfy all the needs of the present domestic bus market.

In order to adapt to the domestic use environment, Yuchai independently developed an ESI gas control system. Gas engine sales of Yuchai grew at an annual rate of over 100% from 2008 to 2012 and grew more than 60% in 2013 with nearly 100,000 units in use on the market.

Leading and applicable plug-in hybrid system

Much hope has been put in Yuchai's hybrid system in amid a rising tide of new energy buses at home. Yuchai has begun to see the use of the system spread and sold 1,300 units in 2012, well ahead of its competitors, earning a reputation as China's "Eaton in the industry. In 2013, after "sharpening the sword for six years", Yuchai's second-generation plug-in hybrid system was successfully developed.

Yuchai's hybrid power system performs well on the two important indicators of energy efficiency and reliability of hybrid buses. Operational data show that Yuchai's hybrid system saves an average of more than 20 % of energy compared with traditional buses.



1,332,826th engine and 25,826th new energy engine rollout ceremony

5.2 Treat "three wastes" to prevent pollution

Guangxi Yuchai Machinery Co., Ltd.'s wastewater treatment plant has an annual capacity of 692,903 cubic meters, uses an online wastewater monitoring system for the implementation of all-weather monitoring, treats 100% of the wastewater produced and will not discharge wastewater until all the standards are met and reclaims 15,523 cubic meters of water annually.

The casting center wastewater treatment station involving an investment of more than 6 million yuan has been completed and put into trial operation. The project treats wastewater produced by the casting center in the production process and domestic wastewater produced by offices and other

facilities in the plant area. The effluent quality meets the *Integrated Wastewater Discharge Standard (GB8978-1996) Primary Standard*.



Casting center wastewater treatment station

Guangxi Yuchai Machinery Co., Ltd. has decommissioned the engine block workshop of its foundry which has been in use for 20 years and is technologically backward and three 5-ton

cupolas, thereby reducing sulfur dioxide and soot emissions produced by burning coke.



Yuchai "AdBlue"

Yuchai makes effective use of "AdBlue"(commonly known as "high-purity urea solution for vehicles") in the SCR after-treatment system to significantly reduce engine emissions. The product was independently developed by Yuchai and analytically pure urea with a purity greater than 99.9% and electronic-grade pure water.

The SCR system uses "AdBlue" to treat nitrogen oxides in the engine exhaust by injecting it into the engine exhaust pipe. Urea undergoes hydrolysis to ammonia when heated. Ammonia reacts with NOx under the action of catalyst to form non-toxic nitrogen and water. It makes engine combustion more efficient and complete, reduces fuel consumption by more than 6% and reduce particle to a level below regulatory limits.

In 2013, Yuchai "AdBlue" sales nationwide reached 600 tons, which, according to theoretical calculations, can improve 50 million cubic meters of harmful gas emissions.

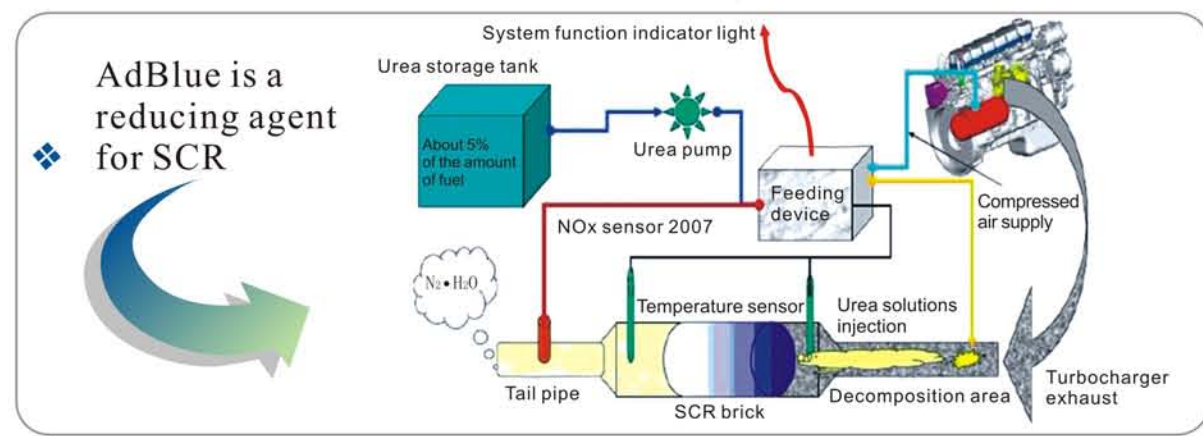

AdBlue is a reducing agent for SCR

5.3 Energy conservation, consumption reduction, recycling and reuse

Promote and apply the technology for conserving energy and reducing consumption

Yuchai Group made great efforts to promote and apply the technology for conserving energy and reducing consumption. All subsidiaries had carried out equipment upgrading and

technical innovation by obtaining the license from competent investment planning authority. Thus, energy conservation was realized.



- Energy conservation upgrading results in remarkable effect in electricity conservation**

The overall electricity conservation rate of the energy conservation upgrading projects like dust-removing fan and compressed air pipe of Guangxi Yuchai Machinery Co., Ltd. reached over 25%. The holding furnace upgrading project in core-making process of the new casting workshop made the holding time of the sand core holding furnace prolonged from 6 minutes to 9 minutes. The qualified rate of sand core was increased from 75% to 100%. The production efficiency was increased by 25%. Throughout the year, electricity charge of RMB130,000 can be saved. The dynamic reactive power compensation equipment in the substation of the casting center of the foundry was formally put into service on August 20. Upon calculation, by using this equipment, the electricity charge reaching RMB856,800/month was saved.
- Upgrading of the water tank of the machine to be tested results in unbelievable effect in energy conservation**

Guangxi Yuchai Power Machinery Co., Ltd. upgraded the water heating device of the water tank of the machine to be tested. By applying the technology of "heating the water for the machine to be tested by exhaust pipe", the water heating time for the machine to be tested was shortened by 50%, the efficiency of the machine to be tested was enhanced. In addition, each year, 23.69 tons of diesel for the machine to be tested was saved. Besides, the Company improved the diesel discharging system of the machine to be tested. Thus, the function of discharging air was realized by pushing one button and the waste of diesel caused by discharging air manually was avoided. Generally, 1.4 kg of diesel fuel was saved for one machine. Throughout the year, 11.85 tons of diesel fuel was saved.
- Improve the quality of lubricating oil and extend the cycle for changing lubricating oil**

Guangxi Nanning Yuchai Petronas Lube Co., Ltd. embarked from such aspects as optimizing the formula, reducing friction, improving the economic efficiency of fuels and extending the cycle for changing oil to improve the environmental compatibility of oils. For instance: by taking such measures as improving the quality of raw materials of oils, reducing the volatility of oils, enhancing the thermal oxidation stability and durability of oils to extend the cycle for changing oils, a remarkable progress was already achieved in shortening the cycle for changing oils for some enhanced products. The oils for enhanced gas engine can last for 30,000km from the original mileage of 10,000km.
- Adopt new materials and new technology and improve the quality of filter**

For the air filter produced by Guangxi Huayuan Filtration System Joint Stock Co., Ltd. for vehicles, the existing iron shell was replaced by full-plastic air filter shell, the existing iron cartridge cap was replaced by PU cartridge cap and the existing ordinary filter materials were replaced by the filter materials with longer service life and higher efficiency. The existing process of rubber coating, baking and curing for diesel filter will be gradually replaced by the process of plastic hot plate welding which is more energy-conservation. The existing structure of single cartridge for oil filter will be gradually replaced by the structure of distributed cartridge to optimize the structure, expand the service life and improve the filtration performance.

The 2013 "Yuchai Cup" National Annual Conference for Electrical Enterprises & the 7th Forum on the Technology for Energy Conservation and Emission Reduction in Machinery Industry sponsored by China Association of Machinery Manufacturing Technology and undertaken by such companies as Yuchai and so on was held in Yuchai Cultural Center on August 7. The conference took "Technology Innovation Makes Enterprises Strong and Intelligent Manufacturing Creates Bright Future" as the theme. There, experts, scholars and corporate representatives were invited to deliver related reports and introduce the new thinking, new method and new result in technology innovation, as well as frontier technology, development status and the relevant managerial experience, etc.



Effectively control energy consumption in production

Guangxi Yuchai Machinery Co., Ltd. put in more efforts in green manufacturing and applied various technologies for conserving energy and reducing consumption. As a result, the energy consumption, water consumption and electricity consumption for producing single engine was effectively controlled. The Company has produced 406,000 sets of diesel engines in Yulin Production Base throughout the year, which is an increase of 20.7% compared with the same period of last year;

the total power of diesel engine produced reaches 534,8 million kW, that is an increase of 15.7% compared with the same period of last year; the total consumption of energy is 57,494 tons of standard coal, that is an increase of 20.2% compared with the same period of last year; the overall energy consumption for producing single product is 141.63 kg of standard coal/set, it drops slightly compared with the same period of last year.

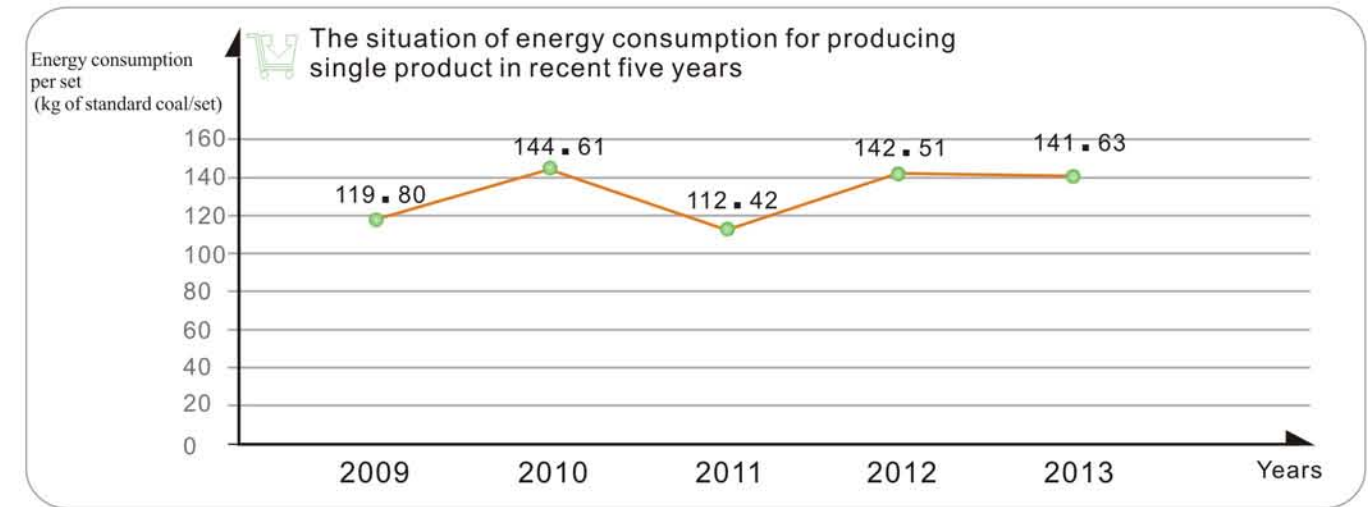

The situation of water consumption, electricity consumption and coal consumption in recent five years

Annually	2009	2010	2011	2012	2013
Water (m ³ /set)	2.22	2.89	2.67	3.55	3.19
electricity (kW·h/set)	349.08	519.29	449.00	556.46	647.97
coal (kg/set)	28.38	25.79	23.62	19.14	0.00

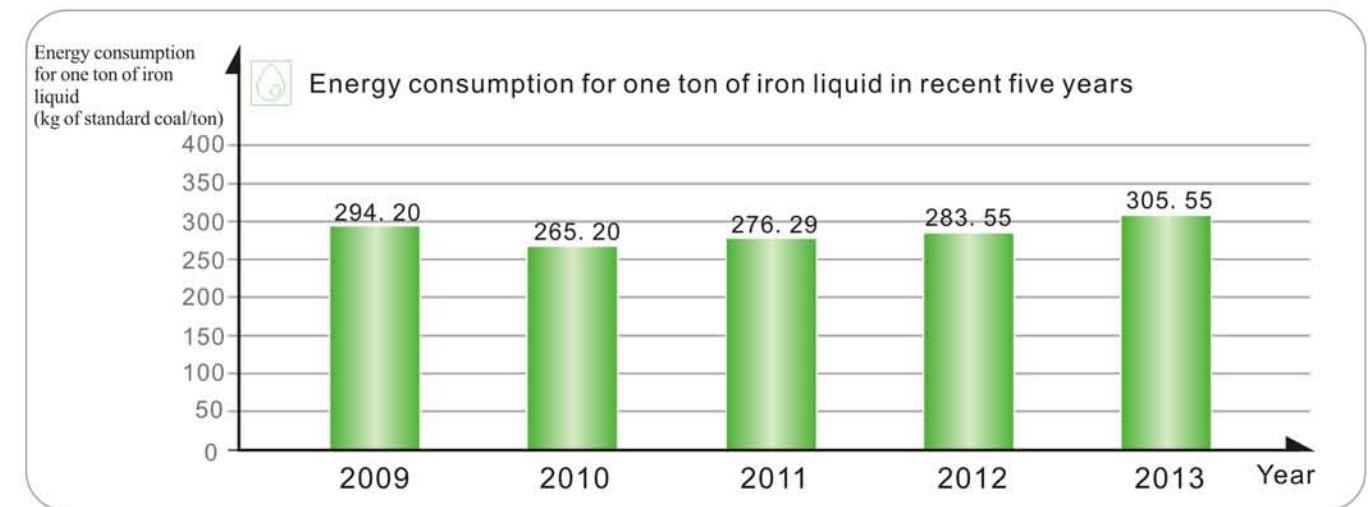

Note: The causes for increase in energy consumption in 2013 compared with that in 2012

The second casting workshop was put into operation in 2013. The newly-added electrical load was approximately 20,000 kW·h. May is the period for trial production, the production efficiency was rather low and failed to reach the designed production efficiency. The electricity consumption throughout the year was 28 million kW·h, only 11,395 tons of casting parts were produced. Thus, the unit consumption for castings was 1,665 kW·h/ton.

5.4 Cleaner Production, improvement phase

Solar photovoltaic power generation

Yuchai Group has already established the largest rooftop solar photovoltaic power station in China. Each year, the power generated from solar photovoltaic station can reach 17.516 million kW·h; over 10,000 tons of standard coal is thus saved; correspondingly, the emission of carbon dioxide is reduced by 25,000 tons; the emission of sulfur dioxide is reduced by 750 tons; the emission of nitrous oxide is reduced by 375 tons; and the emission of dust is reduced by 5,800 tons. Throughout the process, no pollution like gas, liquid or solid waste is generated.



PV modules are neatly laid on the roof of the workshop

Promote environment treatment

Yuchai Group formulated and implemented the Plan on Implementation of Safe Environmental Protection Administration in 2013, which specified the organization, planned activities, department responsibilities, practice, environment management system procedure, process, resources and ability construction for realizing environmental objective.

Yuchai Group monitored and controlled such pollutants as

exhaust, furnace flue gas and industrial waste water generated from production process. It has cleaned 983.3 tons of hazardous wastes, and has carried out harmless disposal to them; it promotes site management. Every week, it will inspect and rectify different production areas from time to time. As a result, the level of site management is increased steadily.

Environmental sanitation equipment adds more luster to "Beautiful Guangxi"

To respond to the requirement of "Beautiful Guangxi · Clean Countryside" and plunge itself into the construction of a Beautiful Guangxi, Yuchai timely developed the product of "YCNG2083 waste compacting & transfer equipment and garbage truck with detachable cargo body". This product can substitute the previous collecting mode like bucket and hoper. Besides, the truck can carry several cargo bodies. Thus, the transportation efficiency is improved and the collection cost is reduced. For this reason, it is unanimously affirmed by the Department of Housing and Urban-rural Development of Guangxi Province and the Environmental Protection Department of Guangxi Province. They plan to promote and apply this product in the whole region. This product once won the second prize of Excellent Result Award for New Products of Guangxi Zhuang Autonomous Region in 2013.



Operation responsibility

- 6.1 Oppose corruption, advocate clean administration and protect the enterprise to maintain healthy operation
- 6.2 Participate in politics and concerned more about the economic development of the state
- 6.3 Run the business according to laws and resist unfair competition
- 6.4 Implement lean supply and cooperate with cooperation partners to perform respective responsibilities



6.1 Oppose corruption, advocate clean administration and protect the enterprise to maintain healthy operation

Yuchai Group always attaches great attention to the task of anti-corruption and clean administration; meticulously implements the policies issued by the Central Government;

continuously organizes honest employment education and strengthens the supervision and inspection, so as to protect the enterprise to maintain healthy operation and development.

Promulgate the ten provisions on working style construction

Yuchai Group promulgated and executed the Provisions on Strengthening and Improving Working Style Construction, forcibly rectify the working style from the ten aspects of improving investigation and research, improving business meeting, improving document processing, improving promotion

and publicity, improving reception service, improving team activity, improving visit preparation, improving vehicle call service, improving leadership, and strictly control travelling abroad, etc., to implement the eight provisions of the Central Government.



Continuously organize honest employment education

Yuchai Group organized clean employment education for new employees, clean administration talk for all cadres that are newly promoted, quarterly electrified education on clean administration, asked the personnel on key posts to sign the Responsibility Document of Honest Employment, demanded the senior management to sign the Commitment Letter for Business Ethics, conducted such activities as topic-oriented training and clean administration caricature solicitation contest and continuously conducted honest employment education, built solid the moral defense line of honest employment for cadres employees. Throughout the year, Yuchai Group has held one

topic-oriented training of Foreign Corrupt Practices Act (FCPA), the number of participants of the training reached over 150; it held one training on professional knowledge for members of Discipline Committee to improve the professional ability of the members of Discipline Committee; it held the electrified education for 3 times, the number of trainees consisting of party members, cadres and employees amounted to over 7,500; it organize the topic-oriented education on clean administration employment for employees engaging in marketing, purchasing and quality line, the number of trainees consisting of cadres and employees reached over 800.



Communication of the culture of clean administration

Yuchai Group conducted the activity of "Qingfeng Yuchai" Clean Administration Caricatures Solicitation and prepared the electronic promotion manual Clean Yuchai.



Prize-winning works by employees in Clean Administration Caricature Contest.

Strictly supervise and inspect the enforcement of disciplines

Supervise the implementation of the system of making factory affairs, party affairs and section affairs open to the public, carry out such sunshine projects as: staff recruitment, cadre selection & promotion, engineering bidding, material procurement, waste disposal, etc., carry out direct supervision for 66 times and sampling supervision for 22 times, investigate and handle 16 cases of letter visits by the masses and forcibly contain the occurrence of corruptions.

The Discipline Committee of Yuchai Group visited 10 supporting enterprises, through such forms as: interview,

questionnaires, etc., supervised and got to know the execution of the Agreement on Clean Administration & Mutual Protection of Yuchai Group and checked whether the personnel of Yuchai Group that have contact with external institutions perform their duties dutifully without any corruption and reviewed the opinions and advices of the supporting manufacturers, so as to promote the construction of anti-corruption and clean administration between both Yuchai Group and the interested parties.

6.2 Participate in politics and concern more about the economic development of the state

As the delegates to the National People's Congress, Yan Ping, the Chairman of the Board of Directors of Guangxi Yuchai Machinery Co., Ltd., and Yu Tianliang, the employee of Yuchai Marine Power Co., Ltd., actively performed their duties as the

delegate to the National People's Congress, participated in politics and offered good ideas for the economic development of the state, which highlighted corporate delegate's true concern for national development.

Being invited to attend the governmental forum on economic trend

On April 12, Li Keqiang, the Premier of the State Council, held the First Economic Trend Experts and Corporate Responsible Persons Forum for the New Administration and reviewed the experts' and entrepreneurs' opinions and suggestions on current economic trend in the first meeting room of the State Council. Yan Ping, the Chairman of the Board of Directors of Guangxi Yuchai Machinery Co., Ltd., as the representative of corporate responsible persons in the field of

machinery, was invited to attend this forum and delivered a speech on the current situation, development, transformation and upgrading of machinery manufacturing industry. The talk between Li Keqiang and him extended from machinery manufacturing industry to energy reservation, environmental protection and the transformation and upgrading of China's economy.



The National People's Congress performs its duties and participates in politics

On March 3, Yan Ping, the Chairman of the Board of Directors of Guangxi Yuchai Machinery Co., Ltd., and Yu Tianliang, the employee of Yuchai Marine Power Co., Ltd., as the delegates of the National People's Congress, went to Beijing to attend the National People's Congress.

Yan Ping put forward the Proposal on Suggesting the State Should Offer Subsidies for the Heavy-duty Vehicles that Satisfy the Emission Standard of Euro IV, appealing the state to facilitate the upgrading of emission standard of medium and heavy-duty commercial vehicle by implementing the policy of terminal vehicle procurement subsidy, enhancing the

competitiveness of commercial vehicles with self-owned brand, and further effectively controlling and reducing the emission of motor vehicles.

Yu Tianliang, as the representative of primary-level workers of the enterprise, started from the actual situation of employment, appealed the governments at various levels, colleges and universities and all levels of the society to advocate correct concept on choosing an occupation and getting employed, so as to provide a guarantee for comprehensively building a well-off society in China.

6.3 Run the business according to laws and resist unfair competition

Yuchai Group insists on operating the enterprise according to laws, engaging in business honestly, strictly abiding by the provisions of the Law of the People's Republic of China against Unfair Competition and opposing to business corruption and unfair competition; the Group sets an independent legal affairs

agency to comprehensively prevent serious cases of corporate disputes; it insists on paying taxes according to laws and sets up a good business reputation and image.

- **Make contract management stricter**
 Yuchai Group always attaches great importance to the management of business contract, implements the concept of managing the enterprise according to laws into the routine work by strict examination of contracts of various types, reduces the occurrence of risks from the root, so as to facilitate healthy operation of the Company. According to statistics, the Legal Affairs Department of Yuchai Group has examined over 7,100 contracts of various types throughout the year, the legality examination rate of these contracts reaches as high as 100%.
- **Voluntarily preserve fair market order**
 Guangxi Yuchai Machinery Co., Ltd. takes "professional segmentation, reliable and applicable" as the starting point, and "special breakthrough and be firstly certified by Euro IV as the breakthrough point, voluntarily preserves the market order of fair competition. The sales of engines maintain the first place in the same industry and the market share is further increased.
- **Actively purify Yuchai engine parts market**
 Guangxi Yuchai Machinery Monopoly Development Co., Ltd. strengthens the responsibility of regional market management, improves the accuracy in combating infringement of brands and products and effectively reduces the cost for combating unfair competition. The cases investigated throughout the year involve a total sum of RMB4.044 million. The average value of one case exceeds RMB100,000. In this way, the lawful equities of the Company are forcibly preserved. The Company integrates the several original management systems, develops the Provisions on Network Management, strengthens the supervision and inspection, promotes the suppliers and distributors to change their business awareness, reduce the occurrence of the phenomenon of violation of rules and regulations and achieves good effect in the purification of accessories market.
- **Strictly combat illegal site of producing inferior lubricating oil**
 Guangxi Nanning Yuchai Petronas Lube Co., Ltd. cooperated with such law enforcement authorities as the publicity security authority, administration for commerce & industry, etc. successful combated 24 illegal site for manufacturing fake diesel in such provinces and cities as Beijing, Shandong, Henan, Shaanxi, Jiangsu, Sichuan, Jiangxi, Hubei, etc. via the means of judicial proceedings, made 43 persons detained for criminal responsibilities, accumulatively detained and investigated over 6 million tons of fake products, the value of cases combated reached as much as RMB36 million. In addition, the company investigated and detained a large amount of raw materials and equipment for producing fake products. In Shanxi, Fujian, Guizhou, Anhui and other regions, the Company successfully combated 31 stores for selling fake products. In this way, the market is effectively purified.

6.4 Lean supply, cooperate with the cooperation partners to perform respective responsibilities

Facing with the stress of serious surplus of the capacity of motor industry in China, as well as the influence of the state economic policy of "adjustment of structure, de-leveraging and de-inventory", Yuchai Group actively promotes the construction of lean supply chain, reduces the cost for both parties and improves the product quality of both parties. The supplier

databank system is established by investigating the overall capacity of the supply chain and conducting a planning over the capacity and realizes the systematic management of supplier information and data; Yuchai also carries out the planning over the information system and strengthens the strategic management of supply chain.

Construct lean supply chain

- Lean training:** Organize the training for the managerial personnel of the suppliers for twice and organize the training for backbones of lean project for three times. The number of trainees involved reached over 150. Within the Procurement Department, the training for popularization of lean knowledge is conducted. The number of trainees involved amounted to 110.
- Lean activity:** A lean communication activity was conducted in Zhejiang Zhoushan with over 30 participants, to allow the suppliers to experience in person the charm of lean production and the actual efficiency thereof.
- Project management:** The Procurement Department develops the two-tier regular meeting system, sets up the code for management of lean supply chain project and has arranged project coaching for 54 times.
The Procurement Department develops the two-tier regular meeting system, sets up the code for management of lean supply chain project and has arranged project coaching for 54 times.
- Project result:** All of the 9 lean projects satisfy the standard and the accumulative definite earnings reached RMB18.539 million.

Result of 9 lean projects

Company	Project name	Before being approved	Project indicator	Completion situation	Improvement rate
Procurement Department of Guangxi Yuchai Machinery Co., Ltd.	Reduce internal losses	1,295TPM	1,150TPM	1,099TPM	15.14%
Procurement Department of Guangxi Yuchai Machinery Co., Ltd.	Improve the punctual delivery rate of purchase order	81.25%	84.41%	88.41%	8.81%
Ningbo Sedsun Vibration Damper Co., Ltd.	Shorten the production cycle of vibration damper	15 days	12 days	11 days	26.67%
Nanyue Fuel Injection Systems Co., Ltd.	Reduce failure rate at the time of assembling	16,685TPM	12,396TPM	8,399TPM	49.66%
Guilin Fuda Holding Co., Ltd.	Reduce the unqualified rate of crankshaft	20.5%	12.1%	9.48%	53.75%
Guangxi Yuchai Crankshaft Co., Ltd.	Reduce the unqualified rate at the time of delivery	16.47%	9.88%	8.01%	51.36%
Zhejiang Sangong Automobile Parts Co., Ltd.	Shorten the production cycle of water pump	68 hours	47hours	28hours	58.82%
Guangxi Qinglong Machinery Manufacturing Co., Ltd.	Improve the punctual delivery rate for exhaust manifold	46%	70%	82.33%	78.98%
Fuzhou Autoparts Industries Co., Ltd.	Reduce the failure rate at the time of assembling flywheel housing	3,168TPM	1,250TPM	363TPM	88.54%

Strictly control purchasing quality

Guangxi Yuchai Machinery Co., Ltd. formulates and initiates the new measure for controlling quality and purchase and lays down the quality threshold and close standard from such aspects as: quality indicator, process problem, rectification effect, etc. As of the quality problem resulting from the fact that the parts provided by the supplier fail to satisfy the agreed requirements, the influence is considerably profound or the effect is rather bad, the equipment fail to satisfy the requirement

for quality competition, the quality close action of different degree will be taken subsequently in consideration of such comprehensive factors as: importance level of the parts, severity of the problem, etc. In case the suppliers have finished the rectification after the close-loop period, they can apply for initiation again. In October, the Company issued the announcement No.1, ordering 5 suppliers to stop production and conduct rectification of their parts.





Regularly conduct technical communication with suppliers

Yuchai Engineering Research Institute will organize the excellent suppliers to gather together to communicate product technology in each month, enhance the overall knowledge of excellent suppliers, get to know the technological result and research orientation of all suppliers and establish a good communication platform for immediate application of new parts technology for diesel engine.





Yuchai and Hunan Oil Pump Co., Ltd. held a communication on technology and quality



The representatives of excellent suppliers accepted the prizes







As the core supplier and loyal strategic cooperation partner of Yuchai, we also achieved fruitful progress in the meanwhile of witnessing the brilliant performance of Yuchai. Weifu Group will continue to cooperate with Yuchai intimately, provide Yuchai with excellent-quality products and considerate high-quality service and realize the strategic vision of building a high-end national brand in connection with Yuchai.

--Chairman of Wuxi Weifu High-technology Co., Ltd., Chen Xuejun



Yuchai Group upholds the core concept of "Green Development & Win-Win in Harmony" and actively promotes the cooperative parties of the supply chain to participate and develop. Yuchai is the first enterprise in China that manages the mass production of the diesels satisfying the emission standard of Euro IV and V and launches them into the market. It practices the concept of green development and brings about the technical upgrading and rapid development of the suppliers like us. We will follow Yuchai closely, build the first-class engine wiring harness and devote ourselves to creating a successful green power and realize the significance of existence.

--General Manager of Yulin Jinshida Electric Co., Ltd., Wang Xuejun

Responsibilities for customers

- 7.1 Improve the quality and ensure that the products are safe and reliable
- 7.2 Discover special potential and satisfy the requirements of different customers
- 7.3 Be thoughtful of the users and provide them with professional VIP service
- 7.4 Strengthen the training and enhance the service level

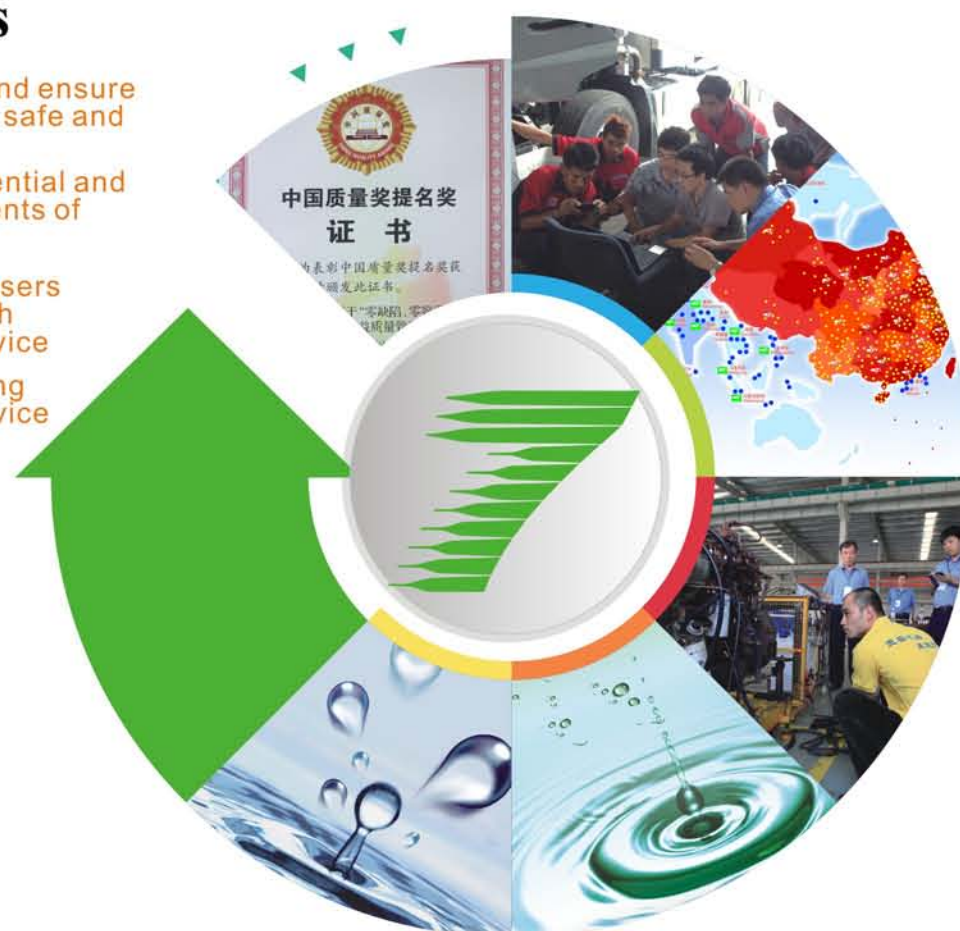

7.1 Improve the quality and ensure that the products are safe and reliable

To ensure that the products are safe and reliable, Yuchai introduces the full life cycle management of products, controls and improves product quality from such processes as: product

planning, design and manufacturing, and provide the customers with safe and high-quality products with high added value.

Implement the full life cycle management of products

The full life cycle management of engines is the management of information and process for the products during the full life cycle including requirement, planning, design, production, distribution, operation, use, maintenance and service, recycling and reuse. At present, a remarkable progress is

achieved in engine management from various aspects. For instance, in the process of technological manufacturing, 6 major specialized plans has already been comprehensively completed, the work mode of full life cycle management is developed in manufacturing process.

The personnel in charge of complete-equipment calibration test and movable bench test carried out a high plateau calibration & verification test in Geermu, Qinghai. The test is mainly done with gas engines in the environment at the altitude of 2,900m, 3,500m and 4,500m. Besides, they also verified and confirmed the upgrading of products, so as to further improve the competitiveness of gas engine.



Introduce lean design

All members of Yuchai Group from the senior level to the lower level start to learn lean design, segment the design specification and procedures into details, establish design databank, strengthen training and delegate responsibilities. As a result, the design capability is remarkably enhanced and the accuracy and effectiveness of the design is also improved.

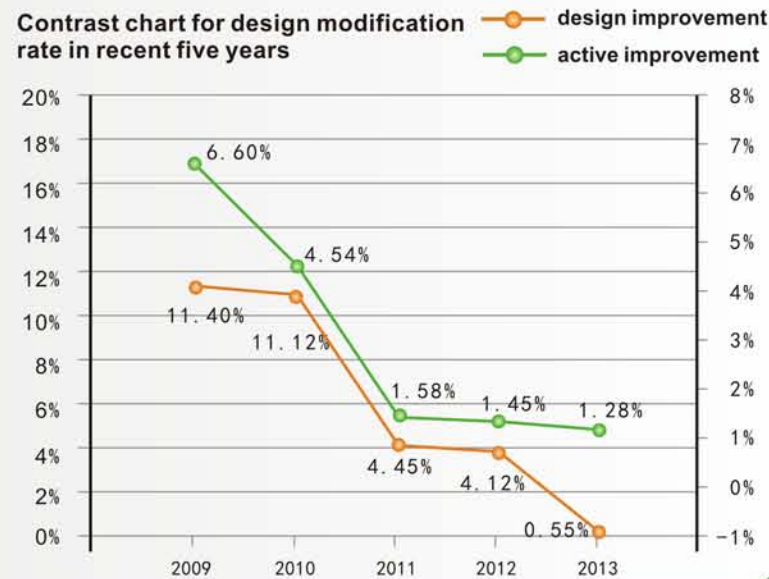

R0 indicator (zero kilometer failure rates) is improved by 100%

Yuchai proposed, in 2011, the target of "increasing the quality by 100% in three years". By the end of 2013, the target of "increase by 100%" was generally realized in R0 indicator of key projects. The target of increasing quality by 100% was realized in large-power marine engines, 6MK, 6L, 4FA and gas engines. Some parts suppliers also realized the target of increasing quality by

100% as scheduled. The average quality for the three years is increased by over 60%. With the increase of sales of engines by 16% throughout the year, the rate of warranty-related compensation drops by 25% compared with the same period, this helps enhance operation efficacy to some extent.

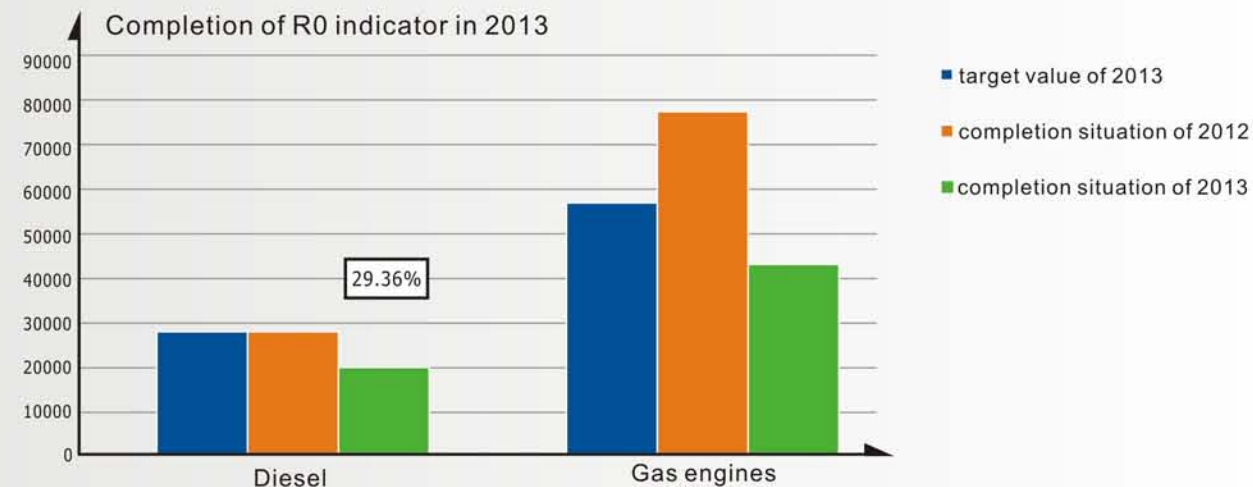

Yuchai Group adopts QMS management and establishes quality information databank to monitor process quality on production site. Throughout the year,

1,060 problems were detected and discovered, that is a decrease of 22.4% compared with the same period of last year and the close-loop rate reaches as high as 97.85%.

Win the nomination to "China Quality Award"

Thanks to the all-member lean quality management mode featured by "zero defect, zero tolerance", Yuchai is affirmed by China Quality Award Appraisal & Commendation Committee and has won the Nomination to "China Quality Award". China Quality Award is a government award provided by the Central Government, organized and executed by General Administration of Quality Supervision, Inspection and Quarantine of the People's Republic of China. It consists of organization award and individual award and is held once every two years. All across China, only 43 organizations and 3 individuals have won such an honor. In addition, Yuchai is also unanimously praised by engine manufacturers and customers for its excellent product quality, and it is assessed by Dongfeng Motor Group Company Limited "the Best Supplier in 2013".



7.2 Discover special potential and satisfy the requirements of different customers

Yuchai takes the users and market demand as the orientation, starts specialized marketing according to different product performance, marketing and service mode requirement, develops specialized products and makes the products and market further differentiated. Meanwhile, Yuchai promotes CRM construction and optimizes the information system. In addition to that, it establishes the customer relationship management system to effectively improve the management level of customer system and better satisfy the business and service requirement of different customers.

markets of highway heavy trucks, diesel truck (Euro IV), light-duty trucks, gas engines, coaches, hybrid vehicles, school buses, environmental sanitation vehicles, crane trucks, construction trucks, concrete mixer trucks, construction/agricultural machinery & equipments and G-drive & large-power marine engines. Yuchai also studies product characteristics in each segmented market and engages in product development and supporting validation in a down-to-earth manner, so as to satisfy the requirements of the users for special functions. For example: the engines using for school buses, high-speed boats and excavators, etc.

7.3 Be thoughtful of users and provide them with professional VIP service

The leader in segmentation of service network

Yuchai expands the construction of special network of off-road engines and engines for agricultural machinery & equipments, rapidly promotes the construction of three-dimensional highway trunks network and recently builds 235 service stations. In this way, it controls the network scale well and makes the network structure continuously optimized. Besides, it develops 143 water system networks, connecting the major water systems and providing timing escort and realizing the fast and convenient service in navigating area. It builds 247 highway service stations, which covers the highway all across the country and realizing the 4-hour-available service in highway main lines; with the key areas being completely covered 1,005 engine electronic system service station satisfying Euro I and IV

have been built. Besides, Yuchai builds 14 regional old part centers to strengthen the recycling of old parts. Thanks to the mutual efforts made by all the members of YC Service Team, the VI image upgrading of 550 service stations is completed. Thus, the external image is improved.



Comparison of quantity of service stations in recent five years

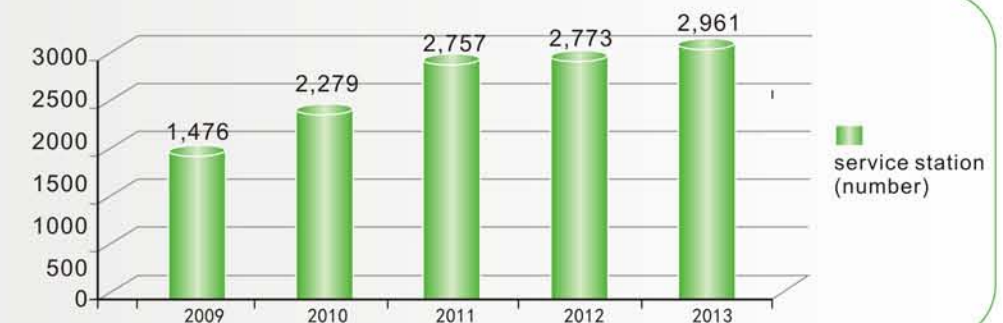

Upgrade customer service platform

Yuchai has established an interactive platform and plans to develop a customer service terminal system to regulate the service process and establish an interactive platform with the customers. Besides, Yuchai also completes the development and shifting of new service system (YCCS), expands its function, realizes the normalization and standardization of management of service such as service station, appraiser's qualification, old parts, oils, accessories, etc.; it integrates and optimizes the business, enhances the convenience, timeliness and

Maintain the advantage of service quality

Yuchai undertakes such specialized work as main engine service month, service for summer harvest, service for autumn harvest, added service for large-power marine engines. Thus, the service for key products is effectively guaranteed. Yuchai guarantees safe use of vehicles with zero fault in the 2nd Asian Youth Games, Nanjing 2013, the 12th National Sports Games of the People's Republic of China in Shenyang and the National People's Congress and the Chinese People's Politics

effectiveness. It also upgrades the call system, customer short-message interaction and closed-loop management and realizes visualized monitoring.

Promote service marketing, realize the promotion of service marketing by policy support, service pulling, taking such measures as experiencing the value, preserving the relationship with customers, discovering the demand and recommending the use.

Consultative Conference, and was thus affirmed by the customers. In 2013, according to the evaluation report issued by China Association for Quality, Yuchai users' satisfaction, anticipated indicators of service quality, the evaluation of service quality perceived all maintain the high level within the industry and the overall evaluation is better than the main counterparts.

Comparison of user satisfaction in recent five years

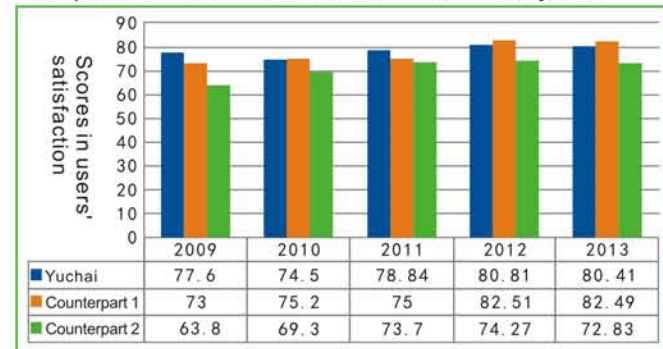

Comparison of service quality perceived in recent five years



Note: Satisfaction index is subject to the result evaluated by China Association for Quality. User satisfaction index is obtained by calculating the comprehensive satisfaction over products, enterprise, service and brand. It is the evaluation of overall satisfaction of the products.

Be dedicated to serve the users

A vehicle team of Harbin Bus Corporation sent us a letter of thanks. It is said in the letter, recently, the vehicle team purchased 45 coaches equipped with Yuchai engines. Afterwards, Yuchai Heilongjiang office took the initiative to serve the vehicle team and conduct a technical service training to the drivers before these new vehicles are launched into service. Since it is cold, it is hard for some vehicles to start up, Yuchai Heilongjiang Office immediately contacted the service station to handle the matter, arrived at the site to give instructions and worked together with the personnel of the service station despite the cold weather. After the efforts over one night, all vehicles can run normally.

7.4 Strengthen the training and improve service level

Yuchai took the initiative to satisfy the Euro IV, popularized new technology and developed the pattern of full coverage with over 1,000 engine electronic system service stations. Besides, it standardized the operation, regulated the process, formulated standards in great details and standardized the service procedure; it provided the tools and equipment, improved the accuracy in appraisal and maintenance; it improved the data, formulated standards, and enhanced the technique level of the service station; it integrated the training resources and exerted overall management over the training base, faculty, teaching materials and teaching tools; it constructed the grade training base, build two Grade II training bases and 30 Grade III training bases, so as to develop the three-dimensional training system consisting of headquarters + bases.

At present, Yuchai has 109 overseas service dealers and 169 service outlets. The network covers 39 countries/regions all over the globe. Therein, 97 service outlets are in Southeast Asia. The service network framework of Southeast Asia is already further improved and the service guarantee capability of Southeast Asia



Yuchai cooperated with Dongfeng Commercial Vehicle Co., Ltd. to organize the service training in Thailand

has been preliminarily developed. Yuchai offered door-to-door training for the customers, conducted the multiple-stage & multiple-level training of theories and practice, so as to enable the customers to better grasp the maintenance technique as soon as possible.



On October 23, the final contest of Yuchai Service Technique for 2013 was held in the customer service center of the sales company. 30 excellent candidates from six major contest areas were admitted, through preliminary contest, to participate in the competition on theoretical knowledge and practical maintenance technique. The main purpose of the technique contest this time is to check and assess the service capability of Euro IV electronic control diesel engines in the service station and the relevant knowledge and technique concerning gas engine, so as to cope with the upcoming era of Euro IV diesel engine and gas engines.



The contest players are diagnosing engine failure



As the loyal customers of Yuchai, we can conclude our comments upon Yuchai with the several characters "reliable quality and high-quality service". Logistics enterprises take vehicles as the important production tools. Thus, it seems of great importance to choose an engine product with unbelievable quality. We are highly satisfied with the high-quality products of Yuchai. Due to our confidence in this product, plus the fast, passionate and considerate service of Yuchai, our fidelity towards this brand is further enhanced.

--Vice Chairman of Shenghui Logistics Co., Ltd., Li Chengguang



High-quality service results in the outstanding achievements of Yuchai. Developing following Yuchai for over thirty years, Yuchai, like a towering tree, offering shade to its service systems and sales systems, over and over again, moves each customer with professional, high-quality, thoughtful and considerate service under the core concept of "Green Development & Win-Win in Harmony". The most avant-garde concepts in the field of sales: technology marketing and service marketing, takes the early opportunity and hence obtains more advantages. It is conducive to today's splendid achievement of ours in the road to Euro IV and V.

--General Manager of Chongqing Kehai Materials Co., Ltd., Liu Haichuan



Over several years, Shuchuang Service Station, upholds the service concept of "with all we have, use all we are endowed, be dedicated to serve the users and be honest to all users", devote ourselves to serve all users of Yuchai, tide over the difficulties and seek mutual development with Yuchai. The gold-medal service quality and profound corporate culture of Yuchai is the guideline for the development of our service entity.

--Senior consultant of Sichuan Shuchuang Vehicle Co., Ltd. and the leader of Yuchai Shuchuang Service Station, Tao Weixiao

Community responsibility

- 8.1 Charity activity, warm affection pervades the community
- 8.2 Education donation, cultural communication
- 8.3 Serve the residents and concern more about their health
- 8.4 Social investment benefits the local region



8.1 Charity activity, warm affection pervades the community

Care about the relatives of nationals living abroad and the compatriots

To implement the policy concerning overseas Chinese affairs, Yuchai Community spares no effort to organize such activities as "Promotion of Law on Protection of Returned Overseas Chinese in the Community", "Loving Heart Enters the Homes of the Family Members of Overseas Chinese", etc., sets in the community the service hotline for the family members of overseas Chinese and sets up the bridge for communication between the family members of overseas Chinese and the nationals living abroad. In November, Yuchai Community is awarded the title "National Demonstration Unit for Nationals Affairs in the Community".



Volunteer action

In July, Yuchai Youth Volunteer Service Team was established. It vigorously promoted the volunteer service concept of "devotion, fraternity, mutual help and progress", practiced the service tenet of "oriented from Yuchai and serve the society", organized and conducted such youth volunteer activities as series activities for welcoming new employees,

reception service for important activity, support to foreign variety performance, volunteers entering the community, volunteer diagnosis & treatment training, inclusive activity in gratitude of the society. The number of volunteers that participated in the service activity amounts to 3,100.



On Mid-autumn Day, Yuchai Youth Volunteer Service Team assisted Yulin Sunshine Coast Rehabilitation Center in organizing the "Mid-autumn Day Variety Performance in favor of One Foundation Ocean Paradise & Sunshine Coast". Over 20 volunteers participated in the chorus of "Love on My Mind" and brought about joys to the children with autistic disorder.

Volunteer worker action

The volunteer worker team in Yuchai Machining Plant is composed of youths at the age of 18 to 35. Currently, there are 80 team members. Throughout the year, inwards, the volunteer worker team has conducted such activities as: volunteer tutoring to the children of the staff in summer holiday, training for the staff on household electrical safety and maintenance, serving mass production, etc. Outwards, the volunteer worker team

conducted such activities as: visiting the lonely elderly people, children, help the students in poverty and hold the variety performance night party, etc. They have conducted volunteer activities for 22 times, and the time of service amounts to 274 hours. Thus, they also contributed their share of efforts to the construction of Harmonious Yuchai, Harmonious Yulin and Harmonious Society.



Spring festival donation good works to the poor areas

The service object in Lizhi Village, Renhou Town is a pair of couples at the age of 90, without a son or daughter, but a girl adopted since it was very young. At present, this girl is already 12 year old. This family is very poor. Thus, they are the key service object for the volunteer worker team. The volunteer worker team will spare no efforts to help them to step out of the predicament.

8.2 Education donation, cultural communication

Devotion of love, help the children to receive education

On May 29, Yuchai Group held the "Love Supermarket" Donation Ceremony, bringing about stationery and comfort fund for the kids. Most of the 35 children of the staff that receive the

donation come from either single-parent families in poverty or the families in which the parents have contracted major disease.



On September 17, Guangxi Yuchai Logistics Group Co., Ltd. responded to the call made by Nanning Logistics Association, organized the "Education Donation & Care for Left-Behind Children" activity in Minglang Village, Napo County, Baise City, donating the teaching materials with value of over RMB10,000 for Minglang Primary School and creating better education environment for the students.

families of Dalian Jiaotong University and provided an award of RMB2, 000 to 3, 000 to ten innovation projects. In this way, the total sum of such awards amounts to RMB173, 000.

On October 9, Yuchai Group granted the scholarship of RMB4, 000 to each of the 36 excellent students from poor

On December 20, the cadres of Yuchai Group donated a lump sum of RMB273, 460.38 in once to "Spring Bud Project". 26 supporting groups developed from over 80 cadres and 55 girls in poverty. They visited the houses and schools of these girls for many times and brought about stationery and nutrients for them.



Establish the National Teaching Practice Base for Vocational Education in Machinery Industry

Yuchai signed with China Machinery Industry Education Center the cooperation agreement as of the matter of establishment of "the National Teaching Practice Base for Vocational Education in Machinery Industry". Both Parties adhered to the principle of "complementary advantages, sharing of resources, mutual creation of results and sharing of interests", cooperated to establish the National Teaching Practice Base for Vocational Education in Machinery Industry, enhanced the social influence and brand of their own and promoted the mutual development of vocational education in machinery industry and Yuchai.



Yuchai engine practical training base

International exchange, cultural communication

The Second Sino-Vietnam Youth Getting-Together with the theme of "Fly Your Dream of Youth and Create Beautiful Future" was formally started in Dongxing, Guangxi. On November 24, over 400 Vietnamese youths arrived at Yuchai

Group for visit and exchange culture, and participated in the interactive party with Yuchai's employees, experienced the culture of the Chinese nationality and established international friendship.



8.3 Resident services, concerns over health

Yuchai assists the community to undertake such work as property services, security, fire prevention, health and sanitation for the owners of the community.

the satisfaction of owners' employers of Yuchai community is 82 scores and the satisfaction of owners of the community is 85 scores. Thus, the overall satisfaction is 83.2 scores.

Upon the evaluation of satisfaction made by the third party,

Project	Content	Data
Living services of the community	Open the hotline of "Smooth Customer Service"; establish the accounts on maintenance period with the function automatic reminding.	Implement 20 items of improvement measures
Security control of the community	Strictly avoid "Shutdown Management"; examine and eliminate gambling sites in the community.	The probability of security case and criminal cases dropped by 14.3% and 125% respectively compared with the same period.
Fire prevention of the community	Conduct the activity of safety production month, the final contest of rewarded contest on safety knowledge and 119 fire protection technique contest.	Strengthen the supervision over fire prevention, re-install or replace 4,560 fire extinguishers, held fire protection training for 25 times and insist on fire operation approval procedure.
Resident health of the community	Organize physical check-up and consultancy for free charges; hold the charity forum on health; send the doctor and medicine to the patients and have a follow-up visit with them regularly.	Accumulatively establish 18,177 copies of resident health archives and conduct physical check-up for 13,744 employees of the enterprise living in the community.



A forum on the Knowledge for Prevention and Treatment of Chronic Disease with Elderly People



A Forum concerning the Health of Females

Yuchai Group invested RMB1.61 million to build an underground channel (Length: 56m, width: 4m; and height: 2.8m) in Yuchai Community, with a view of ensure security for the employees to go to work and go off work and the pedestrians to go across the street.

Entrance of Underpass

8.4 Social investment benefits the local region

Plans to build an industrial new city

"Second phase of entrepreneurship" is the important measure for Yuchai to implement the strategy of "Qiang Chai Xing Yu" and accelerate the transformation and upgrading of the enterprise. The Industrial New City is the important carrier and platform for "starting a new undertaking". Yuchai Group initiated the planning and construction of Industrial New City in November.

The Industrial New City is the development and expansion of the core industry chain of Yuchai. It takes developing high-end equipment manufacturing industry as the subject, takes the

industrial amenities of Yuchai as the orientation, aims at developing a comprehensive agglomeration industrial base incorporating headquarter base, complete-equipment industry, parts industry, terminal equipment manufacturing industry and commerce and logistics industry, strives to achieve the scale of over RMB100 billion (including the current output value of Yuchai Group) in 3 or 5 years and build it into the advanced new equipment (internal combustion engine) manufacturing base in China.



Nanning R & D Base is put into application

Yuchai Engineering Research Institute Nanning Base that is newly put into application is located in the high-tech industrial development zone, covering an area of 81.6mu. Invested by RMB310 million, it is one of the experiment bases with most strength in the research of internal combustion engine in China. This base takes the technology of energy conservation and emission reduction of internal combustion engine as the main vein, targets at constructing the world-class internal base for

combustion engine technology innovation research and result transformation, the national leading base for training of senior innovation talents in the field of internal combustion engine and the R&D platform for providing the whole industry with technological service and promoting international exchange and cooperation. The base consists of R&D building, engine test cells, trial-production workshop, new energy workshop, automatic warehouse and other supporting facilities.



Three projects have already settled down in Yuchai Industrial Park

On September 5, on the Tenth SME Expo Investment Environment Promotion Conference of Yuchai Group in Guangxi Yuchai Industry Park, three contract projects altogether settled down in Yuchai Industry Park, the total investment reached RMB195 million. The three contract projects were namely: the exhaust/inlet pipe, flywheel housing and energy-conservation furnace production project of Guangxi Yulin

Guiguan Machinery Co., Ltd., with the total investment of RMB65 million; agricultural machinery accessories production project of Guangxi Qiangde Machinery Co., Ltd., with the total investment of RMB70 million; agricultural machinery production project of Guangxi Haiyu Machinery Co., Ltd., with the total investment of RMB60 million.

The construction of big castings workshop is started

On November 9, the construction of big casting parts workshop of diesel engine castings project of the Casting Center of Guangxi Yuchai Machinery Co., Ltd. was started. With an estimated investment of RMB200 million, the project consists of five works department, namely: "cold-core core making, resin sand modeling, resin sand reclamation, intermediate frequency

furnace melting and cleaning". Big casting parts workshop is the important project for Yulin machinery industry. It is already listed by Guangxi Zhuang Autonomous Region into the first group of Enterprise Technical Transformation Fund Plan for 2013.

Establish a joint venture to start international investment to operate business

On November 12, Yuchai Group and Hoifu Energy Group Limited established a joint venture. This joint venture mainly engaged in such business as international investment and

operation, including investment and sales of engines, mechanical equipments, special-purpose vehicles, parts, energy and petroleum product, etc.



Project of New energy-conservation diesel engines with small displacement settles down

Yuchai-Runtong New-type Energy-Conservation environmental Protection High-Quality Small Diesel Engine Project with a total investment of RMB3 billion, finally settled down in Longxing Industrial Park of Liangjiang New Area on December 28. This project was jointly invested by Yuchai Group and Chongqing RATO Power Co., Ltd. The annual output of Phase is planned to be 350,000 units of new diesel engine models, the annual output of Phase is planned to be 100,000 units of new models for agricultural machinery, the annual output of

Phase is planned to be 100,000 units of G-drive engines: the total annual output after all phases are put into application will reach approximately RMB 10 billion, the products are mainly targeted at the high-end market in Europe and America. This project will play an important role in filling out the vacancy in off-highway Chinese high-end diesel engine products for the time being and enhancing the manufacturing capacity of high-end diesel engines with low emission in China.

Construct the industrial park for accessories

With the total investment of RMB620 million, the Accessories Industrial Park Project of CSR Yuchai Sichuan Engine Co., Ltd., will achieve the capacity of annual output of

200,000 high-speed engines and ancillary accessories for 800 sets of medium-speed engines after the project is completed.

Overlook of 2014



Business guideline

Starting a new undertaking

Further implement the spirit of such meetings as CPC Third Plenary Session, Central Economic Work Conference and the Conference on Frog-leap Development of New-type Industrialization in Guangxi, standardize the ideology, transform the concept, inspire the passion, grasp the opportunity and platform for construction of Industrial New City, deepen the construction of industry chain of the Group, expand diversified business and promote the enterprise to get transformed, upgraded and start a new undertaking.

Accumulate internal strength

Focus on the eight major core elements of "product, financing, management, market, innovation, development, team and culture", make great efforts to such eight major systematic projects as "product business adjustment, investment and financing platform extension, regulatory system deepening, innovation mechanism reform, marketing strength strengthening, breakthrough in key projects, talent team construction and corporate culture blending", so as to improve the operation level of the enterprise and comprehensively accumulate the internal development strength of the enterprise.

Promote upgrading

Promote the continuous upgrading in management, technology, quality, brand and industry chain and comprehensively improve the core competitiveness of the enterprise.

Scale objective

Ensure that the income from sales reaches RMB46 billion and strive to make it reach RMB48 billion.

Efficiency objective

The total sum of profits and taxes increases in connection with the scale of sales.

Security objective

The number of work-related death, serious injury and fire accident shall be zero and the probability of accident involving minor injury shall be below 3%.

Appendix

ISO26000 Index Contrast Form

Core subjects	Related issues	Information disclosed	Corresponding page Numbers
1 Organizational governance	1-1 Organizational governance	Innovate the governance mode and be a responsible corporate citizen	11
		Strengthen the audit and supervision and ensure the organism of the enterprise is healthy	13
		Deepen cultural construction and cultivate the cultural atmosphere of being responsible	15
2 Human rights	2-1 Due diligence	—	
	2-2 Human rights risk situations	—	
	2-3 Avoidance of complicity	—	
	2-4 Resolving grievances	—	
	2-5 Discrimination and vulnerable groups	Support the disadvantaged groups and preserve the basic rights of employees	19
	2-6 Civil rights and political rights	—	
	2-7 Economic, social and cultural rights	Concern more about the wellbeing of the employees and ensure that the employees live safely and healthily	20
	2-8 Fundamental principles and rights at work	Support the disadvantaged groups and preserve the basic rights of employees	19
3 Labor practice	3-1 Employment and employment relationships	Create more posts and actively arrange employment	24
	3-2 Conditions of work and social protection	Improve the working conditions and establish position-related salary system	24
	3-3 Social dialogue	Implement democratic management according to laws and unblock the channel for dialogue with employees	26
	3-4 Health and safety at work	Strengthen safety production and guarantee the life and safety of employees	26
	3-5 Human development and training in the workplace	Focus on employee education and provide multiple development channels	27

Core subjects	Related issues	Information disclosed	Corresponding page Numbers
4 The environment	4-1 Prevent of pollution	Govern the "three wastes" and prevent pollution	35
	4-2 Sustainable resource use	Energy conservation, consumption reduction, recycling and reuse	36
	4-3 Climate change mitigation and adaptation	Upgrade the technology and effectively reduce emission	32
	4-4 Protection of the environment, biodiversity and restoration of natural habitats	—	
5 Fair operating practices	5-1 Anti-corruption	Oppose to corruption, advocate clean administration, protect the enterprise to maintain in healthy operation	40
	5-2 Responsible political involvement	Participate in politics, and concern oneself with economic development of the country	42
	5-3 Unfair competition	Run the business according to laws and resist unfair competition	43
	5-4 Promoting social responsibility in the value chain	Lean supply, cooperate with cooperation partner to perform respective duties	44
	5-5 Respect for property rights	—	
6 Consumer issues	6-1 Fair marketing, factual and unbiased information and fair contractual practices	Run the business according to laws and resist unfair competition	43
	6-2 Protecting consumers' health and safety	Improve product quality and ensure the products are safe and reliable	47
	6-3 Sustainable consumption	Discover special potential and satisfy the requirements of different customers	49
	6-4 Consumer service, support, and complaint and dispute resolution	Be devoted to serve the users and provide them with professional VIP service	49
	6-5 Consumer data protection and privacy	—	
	6-6 Access to essential services	Be devoted to serve the users and provide them with professional VIP service	49
	6-7 Education and awareness	Strengthen the training and improve service level	50
7 Community involvement and development	7-1 Community involvement	Charity activity, fraternity warms the community	53
	7-2 Education and culture	Education donation, cultural communication	55
	7-3 Employment creation and skills development	Create more posts and actively arrange employment	24
	7-4 Technology development and access	Upgrade technology and effectively reduce emission	32
	7-5 Wealth and income creation	Company profile	7
	7-6 Health	Serve the residents and care about their health	57
	7-7 Social investment	Social investment benefits the local region	57

Form for feedback of Readers' Opinions

Dear readers,

To continuously improve the formulation of social responsibility work and social responsibility report of Guangxi Yuchai Machinery Co., Ltd., we desperately hope that we can listen to your opinions and suggestions. Please help us complete the relevant questions in the opinion feedback form. You can fill out the form and send them to us through mail, e-mail or fax.

1. Overall evaluation of the report (please tick “√” in the corresponding position)

Item	Excellent	Good	Ok	Poor	Very poor
Does this report reflect the current situation of social responsibility work of Guangxi Yuchai Machinery Co., Ltd. in a comprehensive and accurate manner?					
Does this report respond to and answer the questions with which the interested parties are most concerned?					
Is the information and data disclosed in this report clear, accurate and complete?					
What about the readability of this report, i.e., the logical clue, content design, language and format design of this report?					

2. Which aspect do you think is the most satisfactory?

3. Does anything else need to be added in this report since it is not yet concluded in this report?

4. What is your suggestion on our social responsibility work in future and the issuance of social responsibility report?

If it is convenient, please tell us your information like:

Name:	Occupation:
Company:	Address:
Postal code:	E-mail:
Tel:	Fax:

Our contact method is as follows:

Office of Party Committee, Guangxi Yuchai Machinery Co., Ltd.
Address: No.1, Yuchai Avenue, Yulin, Guangxi, China

Postal code: 537005
Tel: 0775-3220651
Fax: 0775-3226887

E-mail: yuchaicsr@126.com
Website: <http://www.yuchai.com>